



VOL. 3, NO. 3, JULY - SEPTEMBER 1976

Second Printing August 1982

# ***SERVICE NEWS***

A SERVICE PUBLICATION OF LOCKHEED-GEORGIA COMPANY, A DIVISION OF LOCKHEED AIRCRAFT CORPORATION



***Ground Handling  
New Air Conditioning Units***

# **service news**

A SERVICE PUBLICATION OF  
LOCKHEED-GEORGIA COMPANY  
A DIVISION OF  
LOCKHEED AIRCRAFT CORPORATION

*Editor*

Jay V. Roy

*Associate Editors*

James W. Buttram

James A. Loftin

*Art Direction & Production*

Anne G. Anderson

---

## **service news**



Cover photo by Lockheed-Georgia Company

Cover: Coast Guard C-130 Hercules on Lockheed-Georgia Company Flight Line. Dobbins Air Force Base in background.

---

Published by Lockheed-Georgia Company, a Division of Lockheed Aircraft Corporation. Information contained in this issue is considered by Lockheed-Georgia Company to be accurate and authoritative; it should not be assumed, however, that this material has received approval from any governmental agency or military service unless it is specifically noted. This publication is for planning and information purposes only, and it is not to be construed as authority for making changes on aircraft or equipment, or as superseding any established operational or maintenance procedures or policies. The following marks are registered and owned by Lockheed Aircraft Corporation: "", "Lockheed", "Hercules", and "JetStar". Written permission must be obtained from Lockheed-Georgia Company before republishing any material in this periodical. Address all communications to Editor, Service News, Department 64-22, Zone 278, Lockheed-Georgia Company, Marietta, Georgia 30063. Copyright 1976 Lockheed Aircraft Corporation.

Vol. 3, No. 3, July – September 1976

## **CONTENTS**

- 3 Hercules Ground Handling**
- 13 Seals for Hercules Purolator Hydraulic Filters**
- 14 Flight Control Cable Tension Regulators**
- 16 Hydraulic Fluid Interchange Between Systems**
- 18 Hercules NEW Air Conditioning Units**
- StarTip**
- 23 First Aid for the Hercules Temperature Control System**

### **DIRECTOR**

**T.J. CLELAND**

### **MANAGER**

**D.L. BRAUND**

**FIELD SERVICE & INVENTORY MGMT**

**A.H. McCRUM**

**CUSTOMER TRAINING**

**A.R. LOVE**

**JETSTAR SUPPORT**

**H.L. BURNETTE**

**SPARES STORES & SHIPPING**

**J.K. PIERCE**

### **MANAGER**

**M.M. HODNETT**

**SUPPLY PROCUREMENT**

**R.C. WEIHE**

**SUPPLY SYSTEMS & INVENTORY CONTROL**

**C.K. ALLEN**

**SUPPLY SALES & CONTRACTS**

**H.T. NISSLEY, JR.**

**SUPPLY TECHNICAL SUPPORT**

**J.L. THURMOND**

# Hercules Ground Handling

The term "ground handling" means different things to different people. To some it includes every operation performed on an airplane from the time it lands until it is airborne again. To others, the term simply means towing and parking – everything else is considered maintenance.

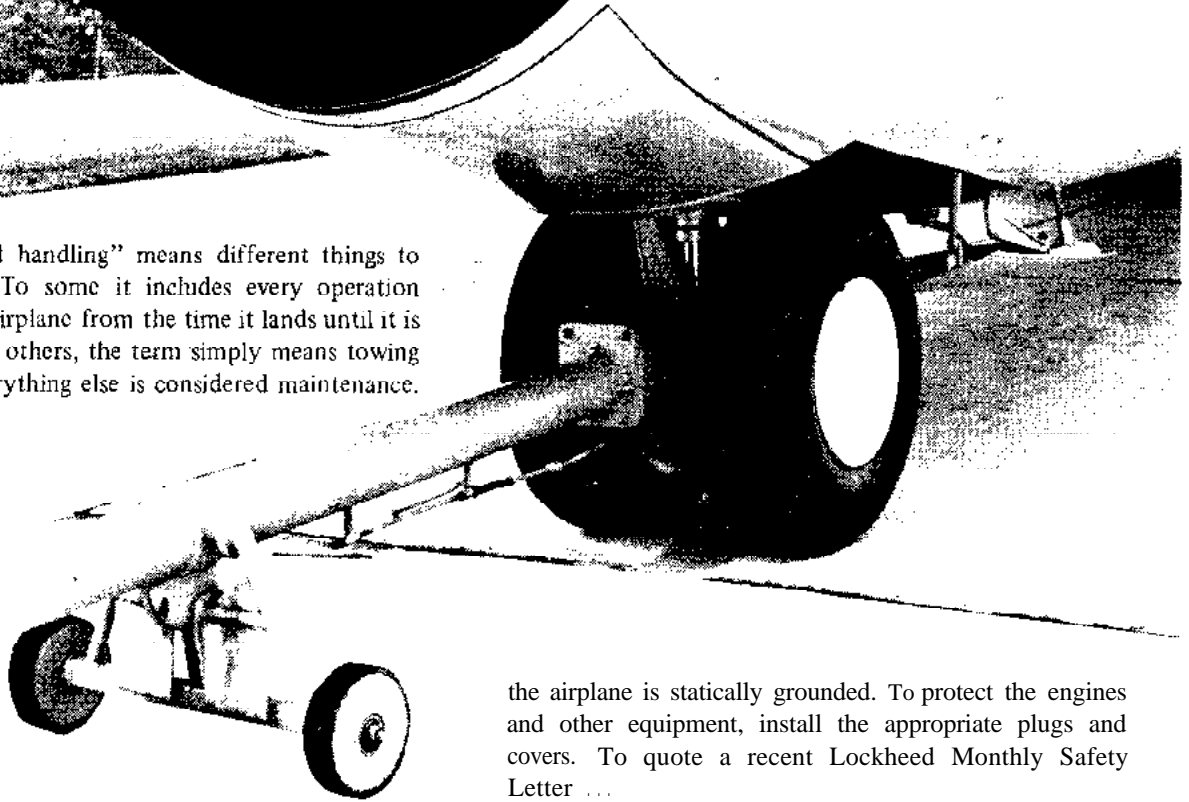

In this article, we will include under ground handling the following subjects:

- ▶ Towing
- ▶ Mooring
- ▶ Parking
- ▶ Jacking

NOTE: Refer to the applicable aircraft maintenance manual for detail information.

## General

The most important consideration in ground handling the Hercules (or any airplane) is SAFETY – for personnel and equipment. You should observe all safety precautions as outlined in the aircraft maintenance manuals, applicable safety rules and regulations. But safety doesn't end with taking specific precautions. Be constantly on guard against any unsafe act. Analyze each move, each task, and think ahead. Prepare check lists to be accomplished prior to each hazardous operation such as towing, servicing and jacking. Before beginning any maintenance operation, make sure landing gear down locks are installed and that

the airplane is statically grounded. To protect the engines and other equipment, install the appropriate plugs and covers. To quote a recent Lockheed Monthly Safety Letter ...

"Too many of us have the conviction that it's only the other guy who needs to think about safety. How many times have you cut a corner or taken a chance in order to get the job done sooner? How often do you perform a job from memory rather than use a checklist or printed instruction? How many times have you said, or thought, or heard, 'I've been doing this job for 20 years and I don't need checklists - they're for beginners'?"

Almost invariably, when we investigate an accident, we find that the individual who is injured or causes damage to property is considered one of the best employees in his organization. We find good reason for this to be true in that usually the 'best' employees are those who jump into a job and get it done quickly. But it takes only a minor distraction, a moment's loss of concentration, an interruption of thought or work process and a crucial step is omitted, resulting in an injury or costly damage ..."

Be especially alert during extreme weather conditions. High winds, rain, snow and other adverse weather conditions add to the normal hazards of ground handling and maintenance.

Inside or outside of the airplane, be careful about dropping tools and parts where they can hit the aircraft skin. A minor dent or scratch in the pressure skin can

*Be alert! Stay alive!  
You can get hurt without even getting close to an airplane*

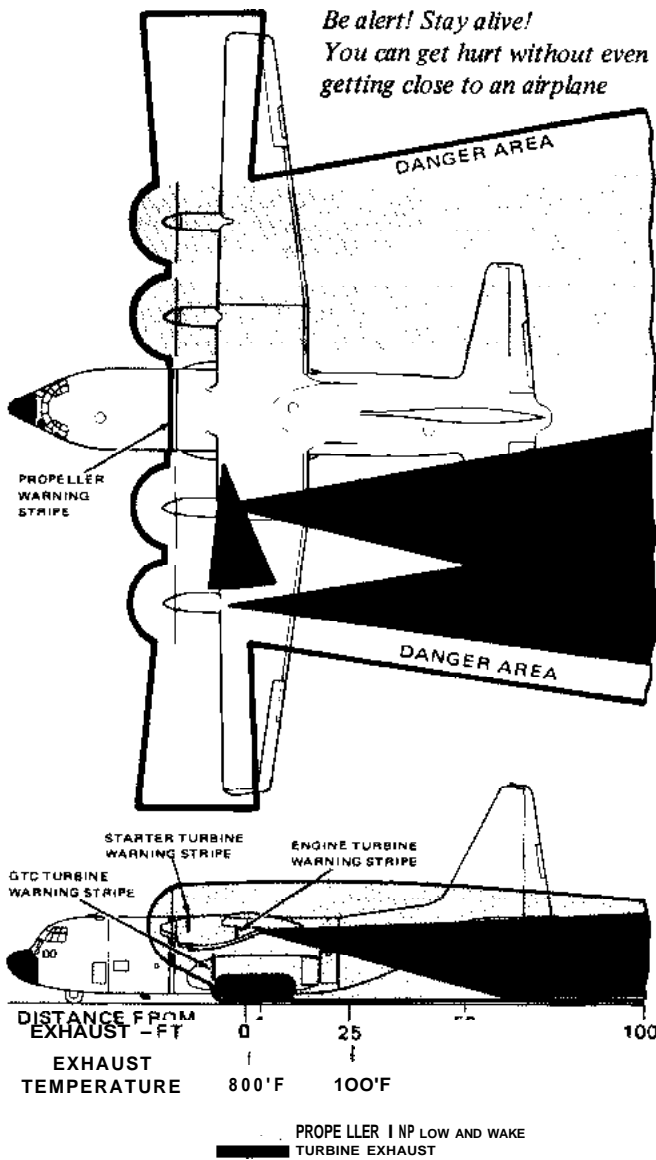

cause a concentration of stress during pressurization, resulting in metal fatigue, then a crack and possible loss of pressurization.

When on top of the airplane, walk within the designated walkways and be careful. Once you slip it is a long way down with no hand holds on the way.

Use the correct tools and equipment. Make-shift and make-do can result in extensive damage to the airplane, lost time in repair, and injury to personnel.

Proper tools, equipment, chocks, static grounding - these are the obvious facets of safe ground handling. But you must look below the surface. Be alert for the not so obvious. Don't become complacent. Treat each task as brand new even though you may have performed it dozens of times. It's the only professional way to do it.

## TOWING

### General

On smooth, hard surfaces the airplane may be towed or backed by means of a towbar connected to the nose gear. If the surface is rough, soft, or uphill (exceeding a 5% slope), tow from the main gear with cables. More about this later.

In preparing for towing, check the charge on the brake accumulators (in the nose wheel well) and make sure the brake system is in good operating condition. Start the GTC and ATM for electrical power (or APU) and ensure that adequate hydraulic pressure (3000 psi) is available from the auxiliary system. If hydraulic pressure cannot be

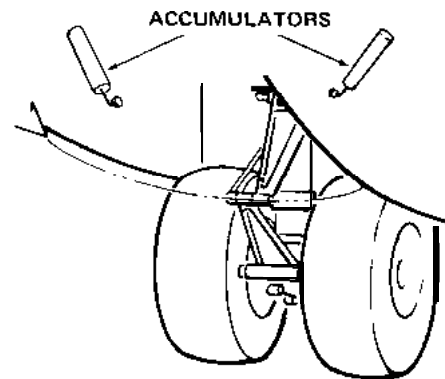

## TURNING RADIUS

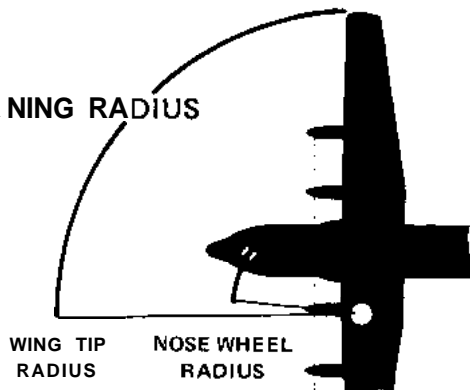

NOSE GEAR TURN IN DEGREES	L-1 00		L-1 00-20		L-1 00-30	
	WING TIP RADIUS	NOSE WHEEL RADIUS	WING TIP RADIUS	NOSE WHEEL RADIUS	WING TIP RADIUS	NOSE WHEEL RADIUS
30°	121' 9"	63' 9"	130' 6"	73' 6"	136' 8"	80' 10"
45°	98' 6"	45'	103' 5"	51' 11"	107' 1"	57' 2"
60°	85'	37'	88'	42' 7"	90'	46' 10"
90°	66' 8"	31' 10"	66' 8"	36' 10"	66' 8"	40' 5"

obtained from the auxiliary pump, station a man at the handpump to keep pressure built up as the brakes are used. For quick brake action, depress the brake pedals, hold them down, and operate the handpump. When it is necessary to use the handpump for brakes, be sure to have adequate communication between the man operating the brakes and the man operating the handpump.

## Nose Gear Towing

The airplane may be towed from the nose gear without disconnecting the torque arms (scissors), but the nose gear must not be turned beyond the red line (60°) painted on the fuselage. Also, with the torque arms connected, it will be necessary to overcome steering system friction and the man operating the brakes should be aware that the steering wheel in the cockpit will turn each time the nose gear is turned. Because of these limitations, and for safer, easier towing, we suggest you disconnect the torque arms for nose gear towing. Release the spring-loaded disconnect handle on the upper torque arm; unscrew the connecting bolt and separate the torque arms; replace the bolt in the upper arm; support the lower arm so that it will not interfere with the forward nose landing gear door. Measure the distance between the upper torque arm strut bolt and the lower torque arm strut bolt. If necessary, inflate the strut so that the distance between the bolts is  $25 \pm 1$  inches. It is preferable to use tow bar P/N 403980-1. However, if a type MD-1 towbar is used, reverse the towbar arms to reposition the attaching bolt heads inboard. This will prevent tire damage.

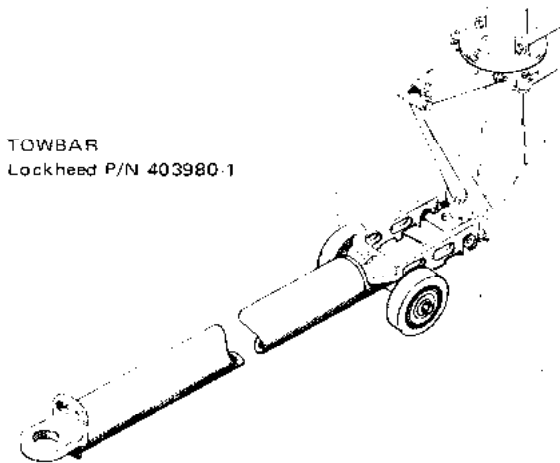

TOWBAR  
Lockheed P/N 403980-1

**NOTE:** To prevent overloading the nose gear structure, the tow fitting is attached with an AN6-12 shear bolt. If this bolt has to be replaced, ALWAYS REPLACE WITH A LIKE BOLT.

## Main Gear Towing

When the surface is rough, soft, or the incline exceeds 5% (3') upslope, tow the airplane from the main gear. (A 5% grade is a 5 foot rise in a 100 foot distance.) Install main gear towing and jacking fittings (P/N 3'71619-1) on the front side of each forward strut for forward towing or on the aft side of each rear strut for aft towing.

When towing forward from the main gear, use one tow vehicle and forward towing cable P/N 104-000 (alternate P/N 402536). The tow cables are fabricated from 53 feet of 1/2-inch steel cable, six strands, 19 wires per strand, with a 5/8-inch, 3-1/4 ton safety anchor shackle on the

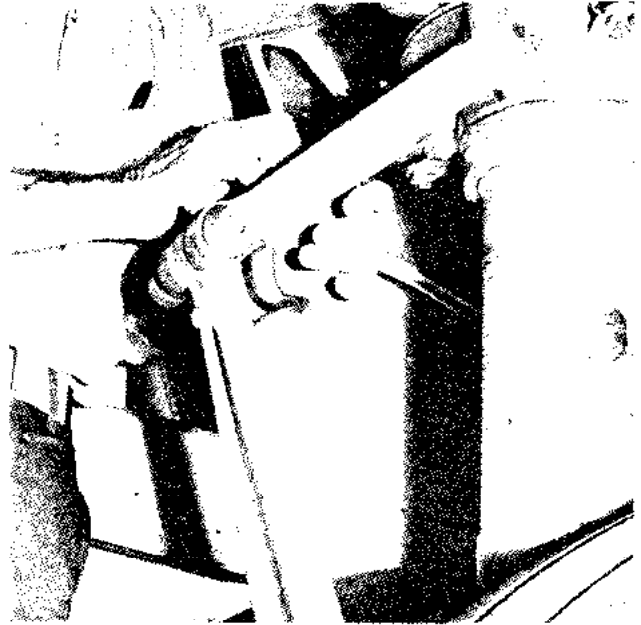

RELEASE THE SPRING-LOADED DISCONNECT HANDLE ON THE UPPER TORQUE ARM.

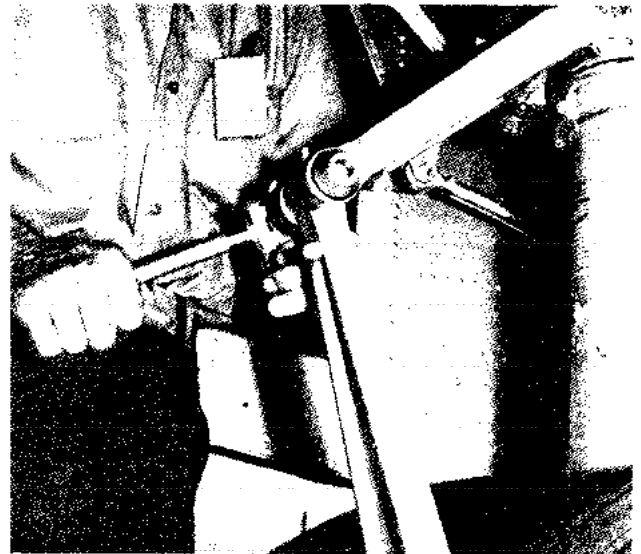

UNSCREW THE CONNECTING BOLT.

SEPARATE THE TORQUE ARMS AND REPLACE THE BOLT IN THE UPPER ARM. SUPPORT THE LOWER ARM SO THAT IT WILL NOT INTERFERE WITH THE FORWARD NOSE LANDING GEAR DOOR.

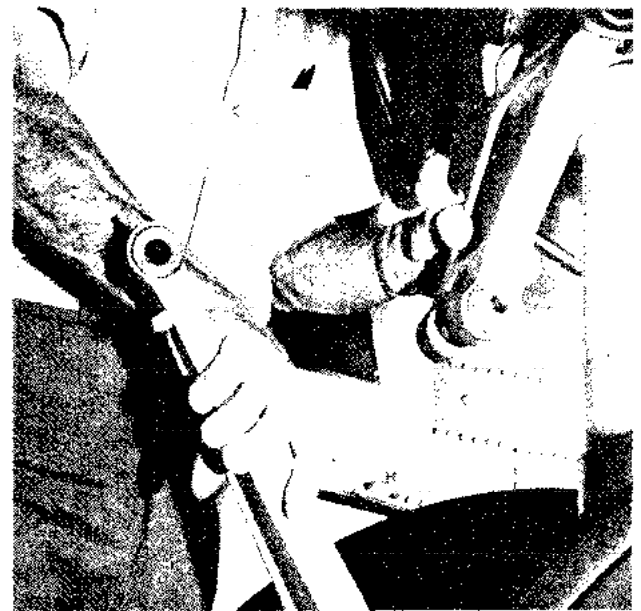

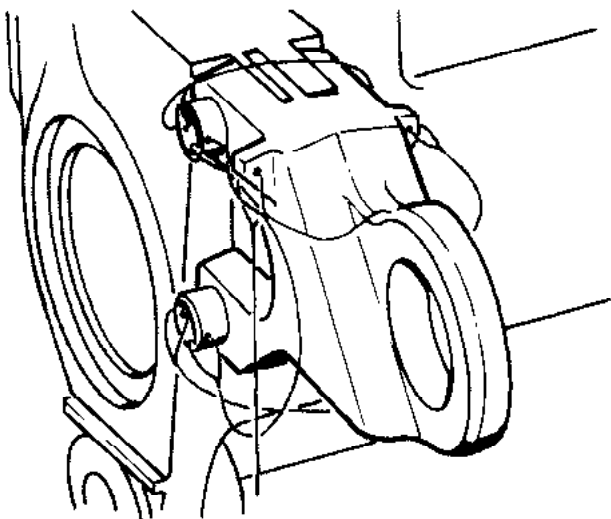

**MAIN GEAR TOWING AND JACKING FITTING**

airplane strut attaching ends and a 7/8-inch, 6-1/2 ton safety anchor shackle on the tow vehicle attaching end. The net length of the P/N 104-000 or P/N 402536 cable is 50 feet (4025369, 59 feet, for -20, -30 Hercules); they converge and require only one tow vehicle.

For aft towing from the main gear, use two tow vehicles and two P/N 105-000 (alternate P/N 402537) tow cables. These tow cables are fabricated from 44 feet of 1/2-inch steel cable, six strands, 19 wires per strand, with a 5/8-inch, 3-1/4 ton safety anchor shackle on the airplane strut attaching end and a 7/8-inch, 6-1/2 ton safety anchor shackle on the tow vehicle attaching end. The net length of the 105-000 or 402537 cables is approximately 38 feet (402537-9, 46 feet, for -20, -30 Hercules), and they require the use of two tow vehicles.

Since nose gear steering is not available during main gear towing, steer the aircraft with the brakes.

### Summary

Applicable documents should be referred to for specific directions and cautions during towing operations. In addition to those already covered in this article, towing precautions include but are not necessarily limited to the following items:

- Don't turn the nose gear until the airplane is moving.
- Tow the airplane in a straight line at least one revolution of the main landing gear wheels before stopping. This relieves side loads imposed during turns.
- Never tow the airplane with any engine(s) operating (GTC or APU excepted).
- Never tow faster than a slow walk. Station adequate number of observers (wing walkers).
- Unless absolutely necessary, never brake to a stop in a turn. Damage to the nose gear and/or structure may result.
- Do not allow anyone to enter or leave the airplane while it is moving.
- Have chocks handy and put them in place when stopped.
- Never tow in winds exceeding 30 knots.

If it is necessary to tow the airplane with components removed (such as props, engines), refer to applicable documents. Further information on moving the Hercules with components removed can be found in *Service News* Volume 2, Number 1.

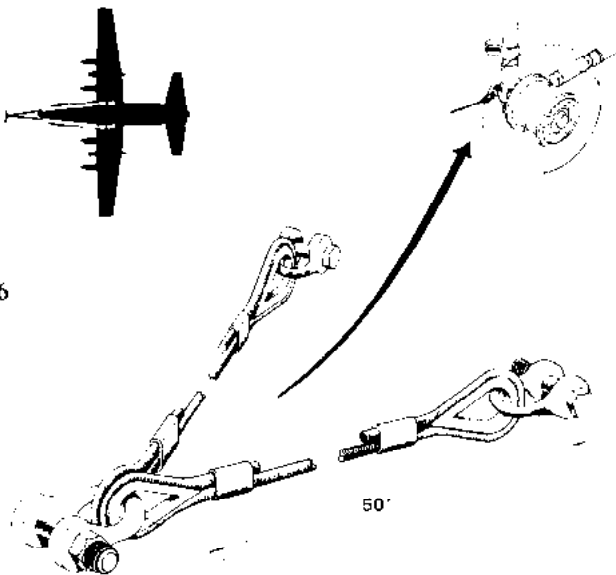

**FORWARD BRIDLE TOWING ASSEMBLY**

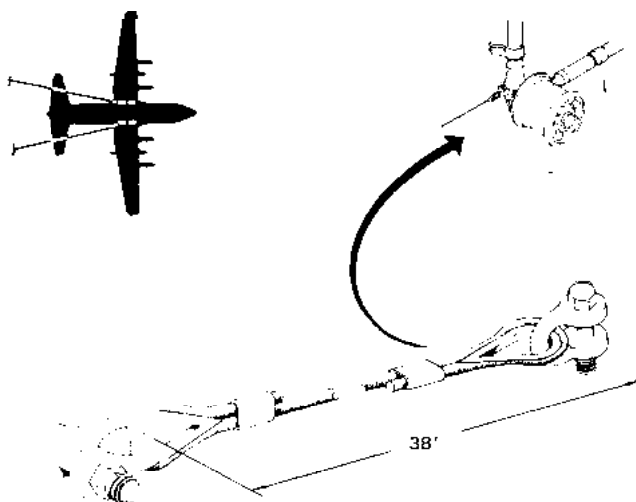

**AFT BRIDLE TOWING ASSEMBLY**

## PARKING

### General

The main gear brakes may be set for temporary parking, but leaks may result if the brakes are left set for extended periods. Never set the brakes while they are hot - the tires will continue to heat, possibly blow out, and result in severe damage to the airplane and possible injury to personnel.

If there is a choice, park the airplane headed into the wind. The size of the vertical stabilizer causes the Hercules to be especially affected by winds and gusts. Position the nose wheel straight fore and aft, chock the airplane, and release the brakes. Reset the brakes only if adverse wind (30 knots or better) is forecast. Install protective plugs and covers. Moor the airplane if forecast weather conditions call for it.

### MOORING

#### General

It is not necessary to moor the Hercules unless forecast weather conditions dictate. However, even in mild winds, the combination of low pressure tires, narrow gear tread, and large vertical stabilizer makes the Hercules subject to yawing motions. This can make some maintenance operations difficult or dangerous - or both. To prevent the airplane from pitching and yawing during mild winds, tie down the nose gear. The wings may also be tied down. Work stands should be moved from under the wings.

When to moor, how to moor, and when to evacuate can be determined from the tiedown requirements charts and the mooring diagrams in the appropriate documents. Mooring fittings are permanently installed in each wing. The inboard fitting is located just inboard of the wing break; the outboard fitting is located approximately halfway between the outboard engine and the wing tip. Two fittings are located on the underside of the fuselage just aft of the leading edge of the horizontal stabilizer and a mooring lug is a part of the nose gear strut. For special mooring patterns, the jacking and towing fittings may be installed on the main gear struts and used for tiedowns.

### WARNING

If possible, evacuate the airplane to a safe area if a tornado, typhoon/hurricane, or winds in excess of 75 knots are expected.

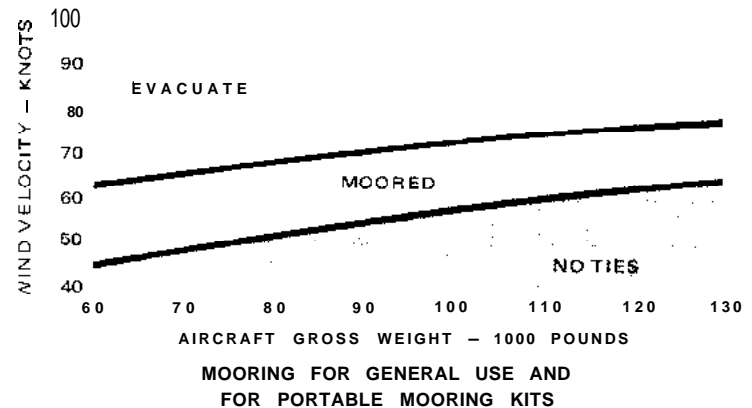
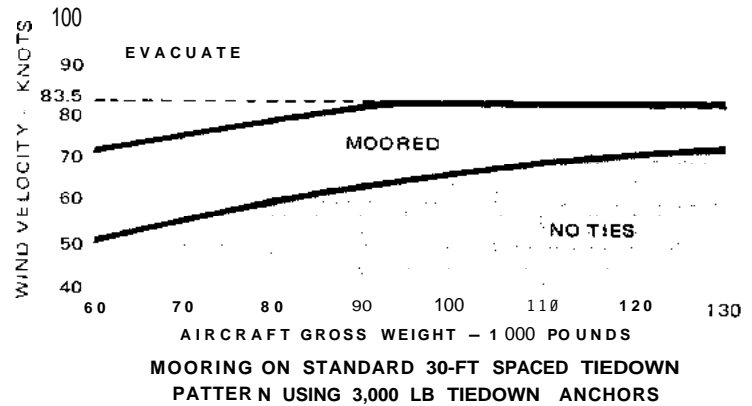
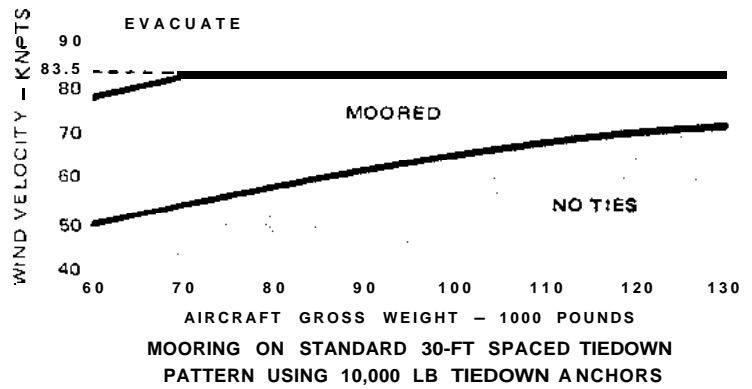
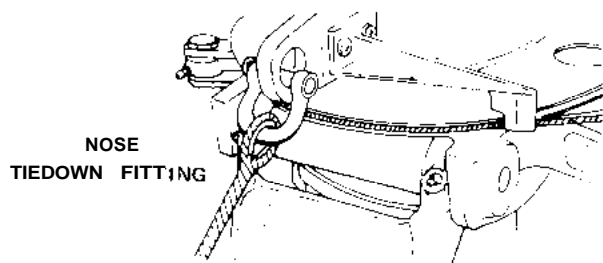

These graphs indicate when high surface wind velocities make it necessary to moor (tie down) or to evacuate the Hercules. Locate the existing gross weight of the airplane at the bottom of the graph. Follow line up to a point on each curve (below and above the "moored" area). Follow horizontal lines across graph to determine minimum wind velocities for mooring and for evacuation.



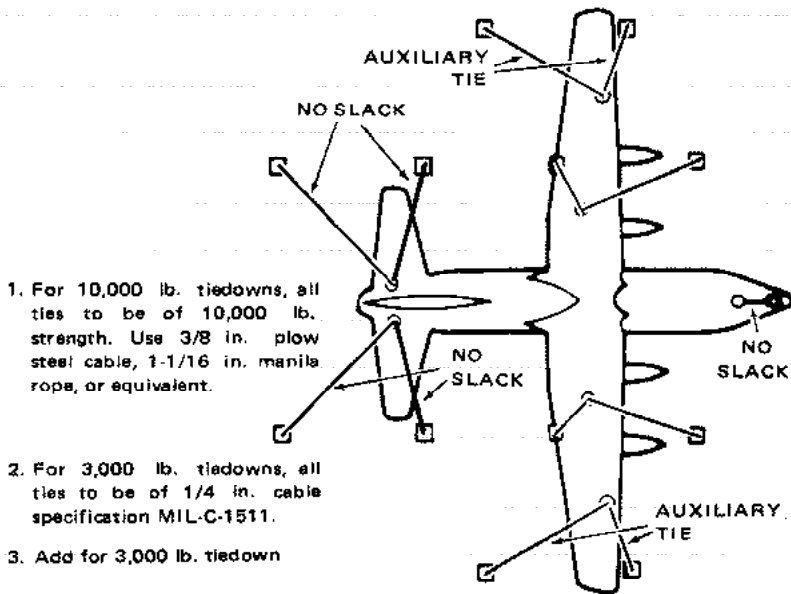

**MOORING ON STANDARD 30-FOOT SPACED TIEDOWN PATTERN**

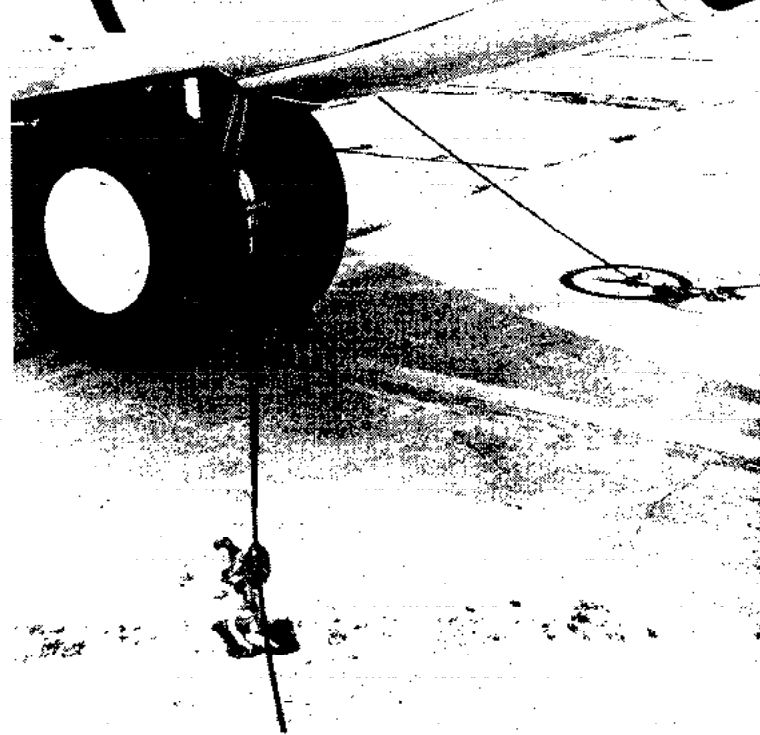

### Mooring on 30-Foot Grid Pattern

For mooring, there is a standard 30-foot grid pattern using either 10,000 pound tiedowns or 3,000 pound tiedowns. Head the airplane into the wind insofar as possible. The primary tiedown is the nose landing gear, so position the airplane so the ground tiedown ring is approximately 34 inches in front of the nose gear with the nose wheel straight fore and aft. This dimension is important due to the closeness of the nose gear mooring lug to the torque arms. If time permits, fill the fuel tanks. Airplane spacing should be one wing span apart if space permits.

In addition to the nose tiedown, there should be one tiedown from each fitting beneath the aft fuselage (tail tiedown), and two tiedowns from each inboard wing fitting. The tiedown should be fastened to the fittings individually, not to each other. For 10,000 pound tiedowns, use chains, 3/8-inch steel cable, or 1-1/16 inch manila rope or equivalent. For 3,000 pound tiedowns use 1/4-inch 7X1 9 steel cable.

The nose and tail tiedowns should not carry any slack - not too tight - just moderately snug. Inboard wing ties should have 9 inches of slack on the forward tiedown and 15 inches of slack on the aft tiedown.

Outboard wing tiedowns (auxiliary tiedowns) may be used for additional security. They should have 3 feet of slack on the forward tiedown and 22 inches of slack on the aft tiedown. The reason for allowing slack in the wing tiedowns is in case of strut collapse or tire failure. Snug wing tiedowns would be overloaded if struts or tires on one side of the airplane went flat.

When mooring with ropes, do not use slipknots. Use an anti-slipknot such as a square or bowline knot.

### Mooring with Kit

There is a portable kit for mooring "off pavement". Enough kits are needed to tie down the airplane at 12 points. Each kit contains anchor rods, arrows, and a driving rod for sinking the anchors into the ground. Use 9/16-inch or larger manila rope. Leave 12 inches of slack in each wing tiedown but make the nose and tail tiedowns snug.

### Mooring on Jacks

It is not recommended, but if it should ever be necessary to leave the Hercules outside on jacks during any wind, tie it down firmly. **USE STEEL CABLE, NOT ROPE.** Draw each cable tight so the airplane can't lift up off the jacks. Place 2" x 4" timbers anchored with sand bags on top of the wing along the front spar to destroy the lift generated by wind flow over the wing.

### JACKING

#### General

The Hercules can be jacked in different ways under varying conditions. It can be jacked with axle jacks or wing and fuselage jacks. It can be jacked in moderate winds. Each landing gear can be jacked individually for tire change or maintenance. Jacks can be used to level the airplane. What to use, when, and how to do it will be discussed here - but a word of caution - refer to applicable maintenance manuals and instructions prior to actual jacking operations.

There is one jacking point for each wing located just inboard of the wing break. Use a tripod jack type B-4A, or



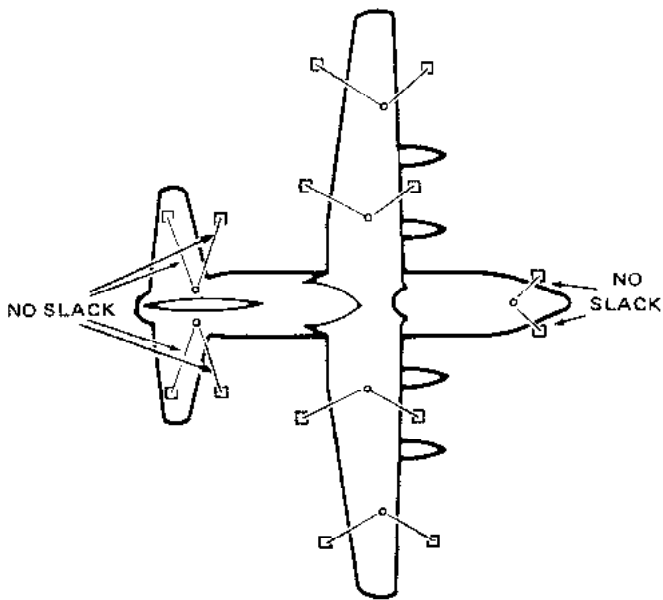

**MOORING PATTERN FOR UNPAVED  
AREAS USING PORTABLE KITS**

Model 8654, or the equivalent. Jack pad fitting P/N 347328 is used in conjunction with the wing jacks. Wing jacks are NEVER manifolded.

Fuselage jacking points are located, one on each side of the nose section, at fuselage station 165. Use tripod jacks Type B-6. or Model 972CT, or equivalent. Jack pad fitting P/N 372447-1 is used in conjunction with these jacks. ALWAYS use two fuselage jacks and ALWAYS manifold the jacks. Use manifold kit P/N 991 AD or equivalent.

**TYPE B-4A WING JACK**

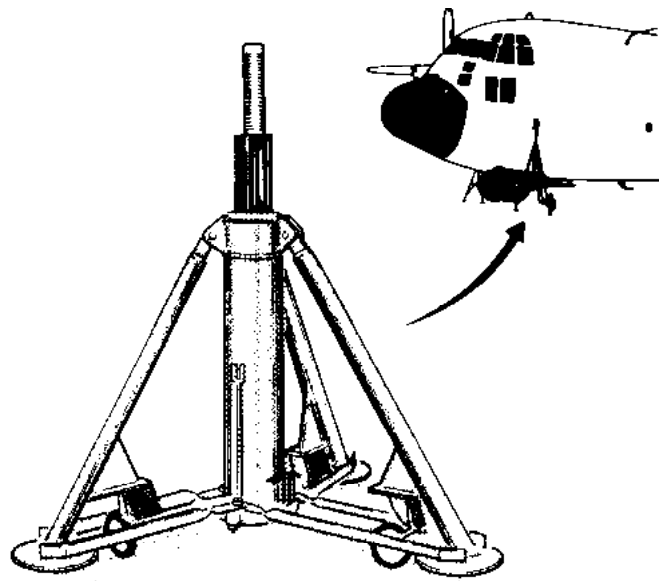
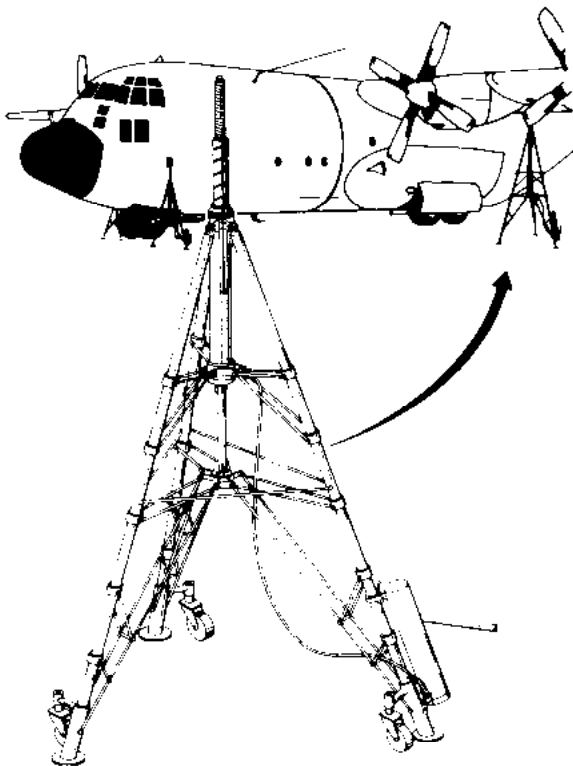

**TYPE 972CT FUSELAGE JACK**

Any time jacks are to be manifolded, they must be the same type jacks.

Each main landing gear strut and the nose gear strut has a built-in jack pad on the bottom. Use a 25-ton axle jack for the nose and 35-ton axle jacks for the main gear.

**TYPE 991 AD JACK MANIFOLD KIT**

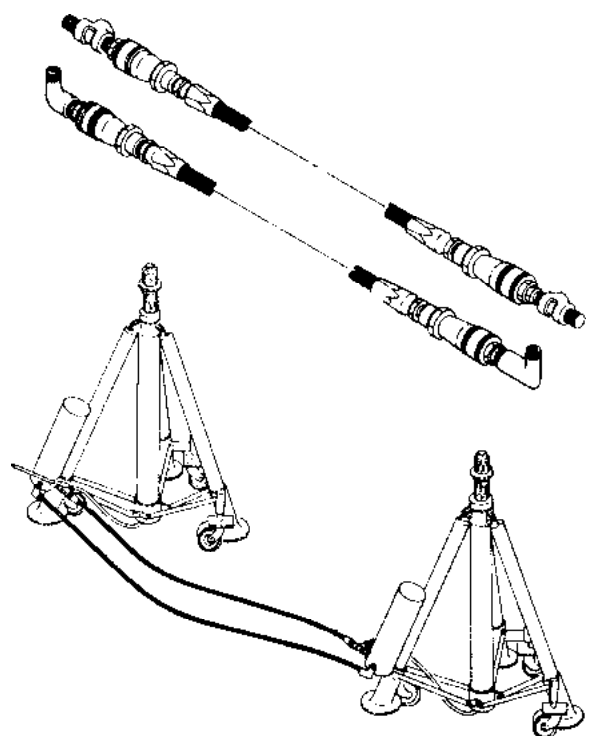

## Axle Jacks

Axle jacks can be used to jack the nose gear and each main gear independently or to jack the entire airplane.

A 25-ton axle jack underneath the nose gear is sufficient to jack the nose of the airplane to change tires or to perform maintenance. If both nose gear tires are flat, it will be necessary to use two jacks and a jacking bar, P/N 402507 or 3402252-1. Always jack only high enough to perform the intended operation.

With gross weights up to 130,000 pounds, each main landing gear can be jacked using a 35-ton axle jack under the built-in jack pad. If gross weight exceeds 130,000 pounds, or if a tire is flat (or both), attach the removable jacking and towing fitting P/N 3716 19-1 to the main gear strut and use a 35-ton axle jack. As an alternate, manifold two 35-ton axle jacks, place one under the forward strut and one under the aft strut and jack both landing gear on the same side simultaneously. Fuel distribution between opposite wings must always be within specified limits.

**ALLOWABLE CG LIMITS  
FOR JACKING**

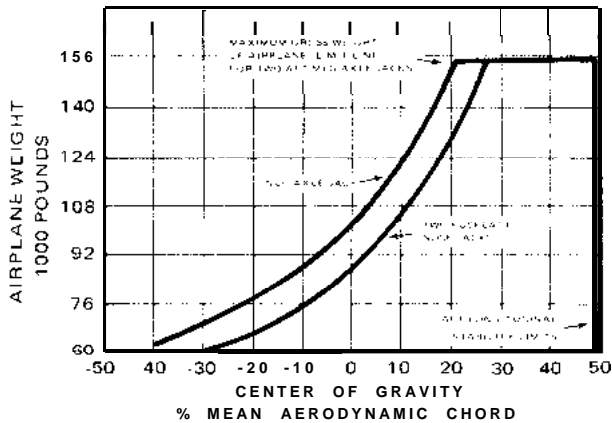

JACKING COMPLETE AIRPLANE USING TWO MLG AXLE JACKS UNDER INTEGRAL JACK PADS ON MLG AFT STRUTS WITH EITHER TWO FUSELAGE NOSE JACKS OR ONE NOSE LANDING GEAR AXLE JACK.

### WARNING

DO NOT PLACE AXLE JACKS UNDER TORQUE STRUTS. CRACKS COULD RESULT, AND IF UNDETECTED, COULD CAUSE SUBSEQUENT LANDING GEAR FAILURE AND INJURY TO PERSONNEL.

The complete airplane can be jacked using a 35-ton axle jack under each rear main landing gear strut and one 25-ton axle jack under the nose gear strut. DO NOT MANIFOLD THE JACKS UNDER THE MAIN GEAR STRUTS.

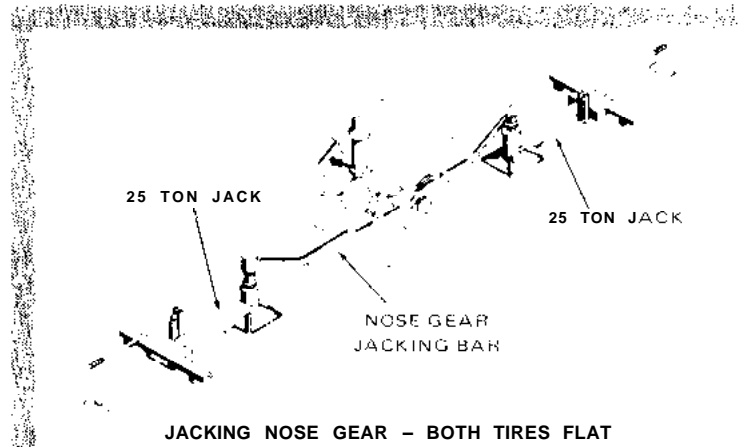

**JACKING NOSE GEAR - BOTH TIRES FLAT**

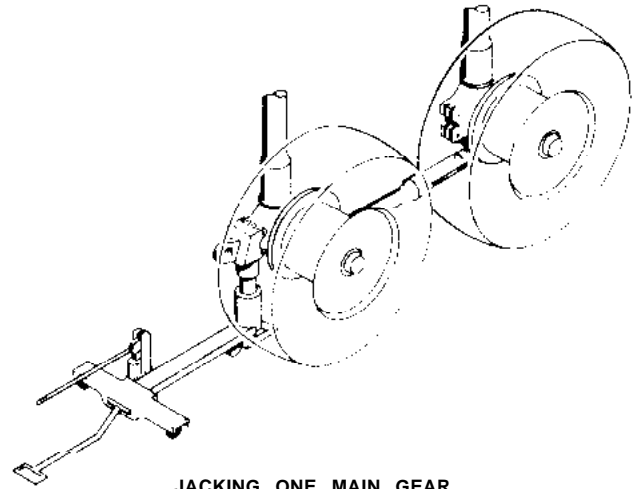

**JACKING ONE MAIN GEAR**

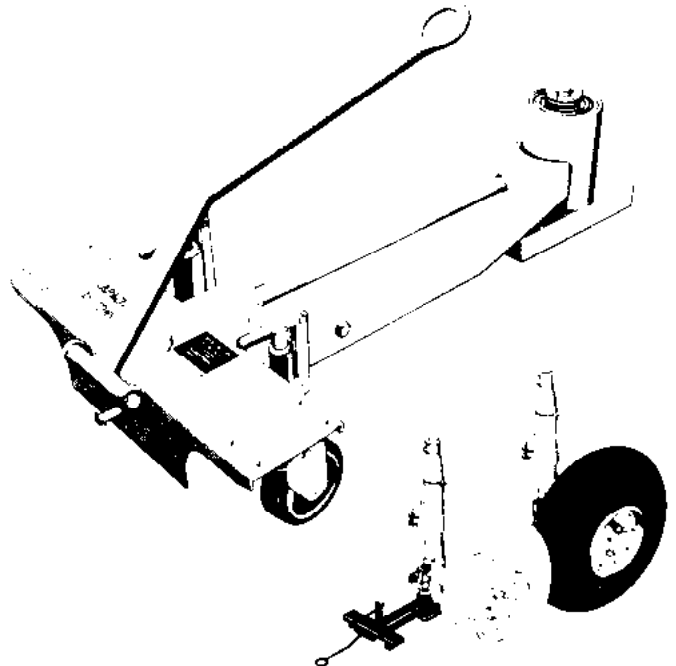

**MODEL 1921 MAIN LANDING GEAR JACK**

## ALLOWABLE CG LIMITS FOR JACKING

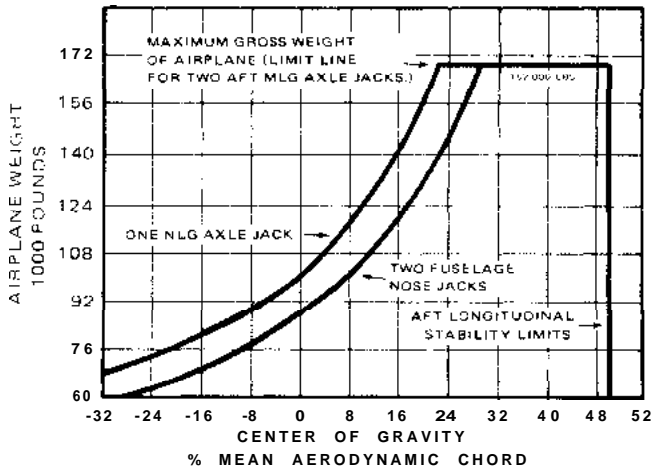

JACKING COMPLETE AIRPLANE USING TWO MLG AXLE JACKS AND REMOVABLE JACKING AND TOWING FITTINGS INSTALLED ON THE MLG AFT STRUTS WITH EITHER TWO FUSELAGE NOSE JACKS OR ONE NLG AXLE JACK, JACKING THE NOSE ONLY WITH TWO FUSELAGE NOSE JACKS OR ONE NLG AXLE JACK.

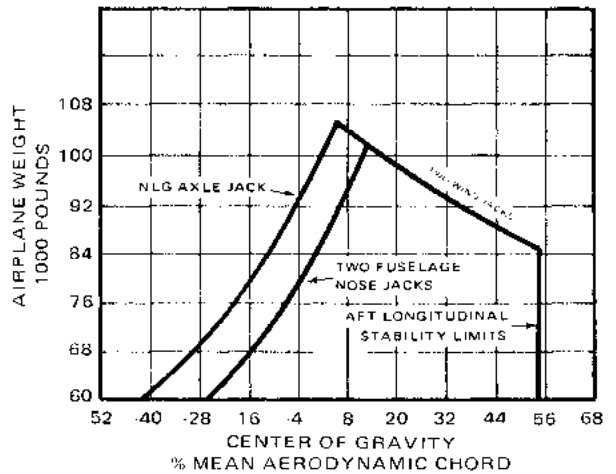

JACKING COMPLETE AIRPLANE USING TWO WING JACKS WITH EITHER TWO FUSELAGE NOSE JACKS OR ON NLG AXLE JACK.

### Example:

Use these graphs to determine whether it is safe to jack the airplane. Pick the graph which shows the method of jacking to be used. Determine the airplane weight and the center of gravity. Locate the point where the two lines which represent the airplane weight and center of gravity intersect on the graph. For example, jack the complete airplane with one nose landing gear axle jack and two aft main landing gear axle jacks used under removable jacking and towing fittings. Assume the center of gravity of the airplane is 18 percent mean aerodynamic chord and the weight of the airplane is 120,000 pounds. Find the point on the bottom of the graph where the center of gravity is 18 percent mean aerodynamic chord; next, find the point on the left side of the graph where the weight of the airplane is 120,000 pounds. Go straight up the page from the center of gravity and straight across the page from the weight of the airplane. Where these two lines intersect is the safety limit point. If this point is below the safety limit lines as shown on the graph, it is safe to jack the airplane. In this example, it will be safe to jack the airplane because the safety point falls below the safety limit line for one nose landing gear axle jack and the safety line for the two aft main landing gear axle jacks.

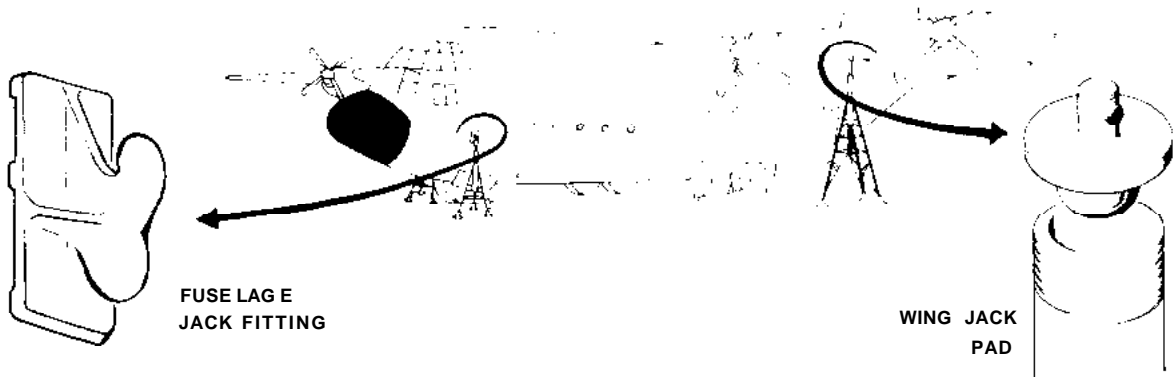

### Wing and Fuselage Jacks

Tripod type wing and fuselage jacks can be used to jack the entire airplane. Install a jack pad fitting P/N 373447-1 on each side of the nose and use Type B-6 or equivalent jacks, MANIFOLDED. This prevents twisting of the fuselage. Install a jack pad fitting P/N 347328 under each wing and use Type B-4A or equivalent. DO NOT MANIFOLD THESE JACKS. Tripod jacks have built-in safety locks to prevent the jack from retracting in case of pressure loss. It also serves to hold the jack extended when it is stopped in a position. It is very important that tripod jacks be level with each leg properly seated and taking its share of the load.

### Jacking Procedure

Even though the entire airplane can be jacked using axle jacks, Types B-4A and B-G tripod jacks should be used if possible. Select a level place for the airplane and a hard, level surface for the jacks. Chock the main wheels and release the brakes. Install the jacking fittings on the fuselage and under the wings. These fittings are usually stowed in a rack on the aft side of the fuselage station 345 bulkhead. Statically ground the airplane. Carefully position each jack directly under its pad or fitting. If both nose gear tires are flat, inflate the nose gear strut to raise the nose far enough to position the jacks under the fittings.

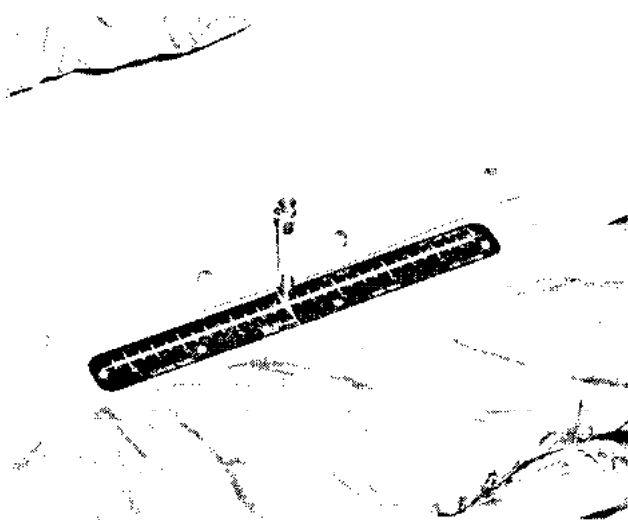

PLUMB BOB INSTALLED AT FUSELAGE STATION 637

Attach a plumb bob at fuselage station 637 above the leveling plate. Ascertain airplane attitude by observing the plumb bob.

If the ground attitude of the airplane as shown by the plumb bob falls between one degree tail down and one degree nose down and a level attitude is NOT required after jacking, maintain the plumb bob indication during the jacking operation. If a level airplane attitude is required after jacking, level the airplane as discussed later under LEVELING.

Jack the airplane to the required height only. NEVER JACK HIGHER THAN NECESSARY. Keep the safety locks on tripod jacks within one-fourth inch of the shoulder. When stopping the jacks, run the safety collars down against the shoulders of the jacks.

The Hercules can be jacked in moderate winds. With winds in excess of twenty knots but not exceeding 4.5 knots, use the following procedure:

- Position the airplane into the wind, and conform to the 30-foot spaced tiedown ring grid pattern.
- Increase the gross weight of the airplane to fall between 70,000 pounds and 100,000 **pounds**. Any ballast that is added must be positioned so the airplane center of gravity falls within twenty (30) inches, forward or aft, of fuselage station 500. Check the center of gravity and weight location charts.
- Attach mooring cables, including auxiliary tiedown cables.
- If wing jacks are to be used, attach three guy cables, 120 degrees apart, to the top-most intersection of the jack legs: bring them taut to stabilize the jacks.

- Carefully place 2" x 4" timbers, 10 to 14 feet in length, end to end along the forward wing spar to extend wing tip to wing tip. Lay each timber on its 2-inch edge, and place a 30-pound sandbag at each intersection of the timbers to anchor them. This will disturb air flow over the wing and prevent the generation of a lift force,
- During the jacking operation, keep the nose and tail tiedown cables finger taut. The wing tiedowns should not be taut, but not over two inches of slack.
- When the airplane is jacked to the required height, secure all jack safety locks, relieve jack pressures, and make taut all tiedown cables.

#### Lowering The Airplane

Use the utmost caution in lowering the airplane.

- Completely clear all tools, work stands, ladders and other equipment from beneath any part of the airplane.
- Apply just enough pressure to the jacks to permit the safety locks to be run up about one-fourth inch off the shoulder of the jacks. **RELEASE THE SAFETY LOCKS OF THE WING JACKS FIRST.** Keep the safety locks approximately one-fourth inch from the jack shoulder while lowering the airplane.

#### Leveling

If a level airplane attitude is required after jacking, level the airplane as follows:

- If the plumb bob indicates a nose-down attitude, use manifolded fuselage nose jacks to raise the nose until the airplane is level, THEN position the wing jacks and jack the airplane. Position an observer at the plumb bob to direct the jacking operation to keep the airplane level. Adequate communications are important.
- If the plumb bob indicates a tail-down attitude, use the wing jacks to level the airplane, THEN position the fuselage jacks (manifolded) at the nose and jack the airplane. Again, an observer at the plumb bob station with adequate communications is necessary.

#### CAUTION

The above leveling procedure is for jacking for maintenance type operations. For symmetry and alignment checks, use the leveling procedure in the Structural Repair Instructions. One difference, for example, is that wing jacks cannot be used to jack the airplane for symmetry and alignment checks.

## SAFETY PRECAUTIONS

In addition to consulting applicable technical manuals and procedures prior to jacking the Hercules, the following should be adhered to:

- Be sure the center of gravity and gross weight are within the safety limits.
- Do not jack the airplane if wind or gusts exceed 45 knots.
- Statically ground the airplane.
- Do not jack the airplane with the cargo ramp resting on the ground.
- Be sure all jacks are on a firm, level surface. With wing and fuselage jacks (tripod), each leg of the jack must carry an equal amount of the total weight.
- Always manifold fuselage (nose) jacks.
- Always manifold axle jacks when jacking two main gear struts on same side
- Never manifold wing jacks or axle jacks under left and right struts.
- Be sure nose gear torque arms (scissors) are properly connected.
- Do not attempt to jack the airplane by inflating the shock struts.
- Do not extend the wing jack ram screw beyond the 15 inch maximum.

We can't discuss here every conceivable ground handling problem. Operating conditions at your base of operations may require changes and deviations from the standard. We do urge you to check your maintenance manuals, be familiar with your own operating rules and safety regulations, and plan ahead. Standard operating

procedures and check lists can go a long way toward safe and professional aircraft handling, but there is no substitute for stopping and THINKING.

**SERVICE NEWS**

13

# seals for Hercules Purolator hydraulic filters

In the chart "Seals for Servicing Hercules Hydraulic Filters" (Service News Vol. 3, No. 1, January March 1976) the seals listed for the Booster Case Drain filter.

the Booster Main Return filter, and the Utility Case Drain filter are for Bendix type filters. If you have Purolator type filters installed in these locations, use the following:

SEALS FOR SERVICING HERCULES HYDRAULIC FILTERS			
FILTER	REQUIRED	MS PART NUMBER	AN OR VENDOR PART NUMBER
<b>Booster Case Drain</b>			
O-Ring	1	MS28775-223	AN62301
Backup Ring	2	MS28774-22	AN62441
<b>Booster Main Return</b>			
U-Ring	1	MS28775-228	A N6230-6
Backup Ring	2	MS28774-228	AN6244-6
<b>Utility Case Drain</b>			
O-Ring	1	MS28775-228	A N6230-6
Backup Ring	2	MS28774-228	AN6244-6

Seals for the auxiliary system remain as shown in the chart for either Bendix or Purolator type filters.

Please amend your chart to reflect the above listed seals for Purolator filters.

**SERVICE NEWS**

# Flight Control

## Cable-TENSION-Regulators

by T. E. Huddleston, *Lockheed Representative, Eastern AFRR*

One little understood item on the C-130 aircraft is the flight control cable tension regulator that is used in the aileron, rudder and elevator cable control systems. As a result, many man-hours have been wasted during replacement of booster packages and in rigging the cable control systems. We believe the following description of the cable tension regulator and its operation will help to alleviate this situation.

The principle of operation of the cable tension regulator is illustrated in the simplified drawing shown below.

two nuts, the screw assembly is free to rotate and if it were not for the two springs which oppose the outward movement of the nuts and their respective stops, the screw assembly could rotate free of the two nuts. As it is, the springs maintain a constant cable tension on the nuts.

The flywheel in the center of the screw assembly is positioned between two friction washers (7) and when more tension is applied on one end than on the other, the flywheel rubs against the friction washer on one side and stops the rotation of the screw. Only when the tension on

14

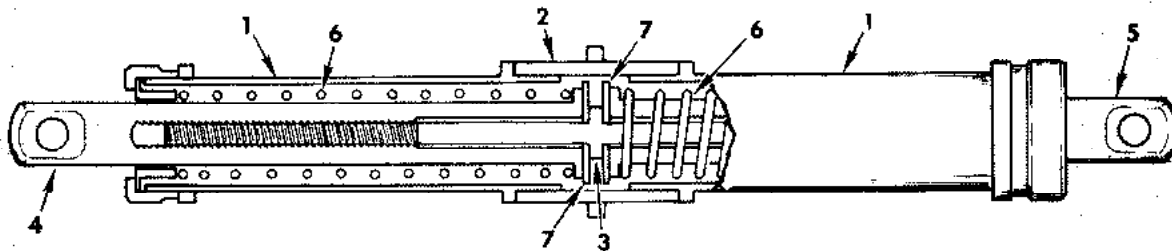

1. BARREL (2 EA)
2. COUPLING
3. SCREW ASSEMBLY
4. NUT, RIGHT-HAND

5. NUT, LEFT-HAND
6. SPRING (2 EA)
7. FRICTION WASHERS

**CABLE TENSION REGULATOR ASSEMBLY**

The regulator assembly consists primarily of two barrels (1), held together by a center coupling (2), a screw assembly (3), two nuts (4 and 5), and two springs (6). The screw assembly consists of high-lead threads on each end of the screw shaft, with right-hand threads on one end and left-hand threads on the other. The center of the screw assembly is enlarged to form a flywheel which performs a braking action in conjunction with two friction washers (7).

Screwed onto the end of the screw assembly are the nuts, which we would normally think of as pistons. These nuts are slotted and keyed to prevent them from rotating. When tension is applied equally to the outer ends of the

both ends is equal will the flywheel be free to rotate, since there is only a small clearance between the flywheel and the friction washers. As a result, the screw assembly is prevented from rotating anytime that control column movement is initiated or unequal forces are applied from the control surfaces.

The tension regulator maintains operating tension within the specified range and provides enough flexibility for accurate rigging adjustments. The tension regulator will lock when approximately ten pounds more pull is placed on one end than on the other. This can cause a problem for the unwary person who fails to block the flight

control cables before removing a booster package. Good operating procedures call for blocking the cables before replacing booster packs.

Should the springs be highly compressed by a heavy application of tension to the ends of both nut assemblies, and then the tension released on only one of the nut assemblies, the resulting friction and heavy application of spring force can cause the regulator to remain locked after all tension is removed from both nuts. By reapplying an equally heavy tension to the cables, the lock can be released. A rap on the side of the regulator assembly can also produce the same results.

**TO BLOCK THE CABLE TENSION REGULATOR,** remove the panels covering the cables at the FS 245 bulkhead and exert an even pull on the pair of cables for the tension regulator to be blocked. Pull the cables outward sufficiently to fully extend the regulator - maximum extension is five inches. Insert the blocking device between the end of the regulator barrel and the nut for the bolt that is used for attaching the cable end to the regulator. Release the pair of cables and the spring force of the regulator will hold the blocking device in position. Reverse the procedure to remove the blocking device.

A simple blocking device can be made from a one-half inch diameter aluminum tube cut to a length of 2.9 inches. Aluminum tubing is preferred over steel since aluminum provides a better gripping surface than steel. Other blocking devices can be used, such as drilled blocks that are clamped on the cables and clamps that are attached on the tension regulator; however, the aforementioned blocking device is easier to manufacture and install.

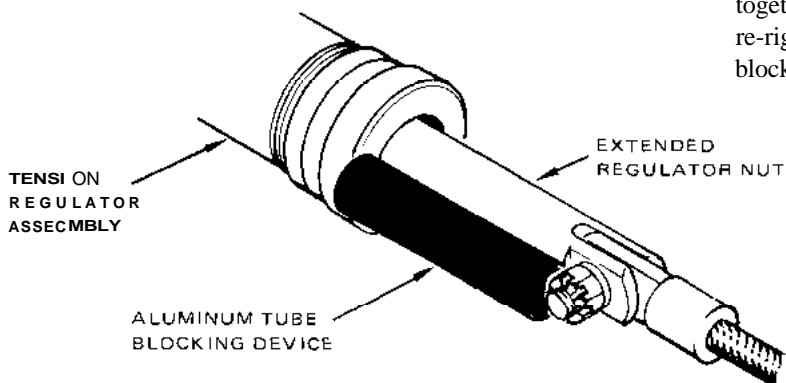

TENSION RELIEVED ON CABLE TENSION REGULATOR

In the case of the rudder, only one set of control cables and one tension regulator are involved, but the aileron and elevator booster packs have two tension regulators, each of which must be blocked - one for the pilot's controls and one for the copilot's. All are located beneath the pilot's and the copilot's flooring and are reached by removing the pilot's and the copilot's seats and then the floor panels. They can also be reached by removing the "kidney" access plates at the top of the nose wheel well diaphragm.

When removing the blocking device from the tension regulator, pull on the pair of applicable cables to relax the pressure and remove the blocking device. Slowly release the pull on the cables simultaneously and permit them to retract to their original length. A sudden release of one cable before the other can effectively lock the tension regulator. Should this happen, rap on the side of the regulator barrel with a small mallet or even the wooden handle of a screwdriver. CAUTION: Take care not to damage the regulator with a metal object. The regulators can also be unlocked by placing a heavy even pull on the cable pair; however, the force that is sometimes required can possibly result in damage to the cable system. The rap on the side of the regulator is easier and much more effective. Should you attempt to hook up unblocked cables to a booster pack, you'll find that it's nearly impossible to do so. For one thing, with the rig pins installed the cables will be too short due to the action of the tension regulator. Some people have attempted to overcome this by removing the torque tube rig pin. They have been successful in hooking up one of each pair of cables to the elevator and aileron boost packs; however, with the one cable hooked up, the tension regulator is effectively locked. As a result, there is no way to hook up the other cable. The only solution is to disconnect the cable, unlock the regulator and extend both cables together. When this is done the cable system must be re-rigged per the applicable maintenance manuals. Now block the regulator and the job is easy.

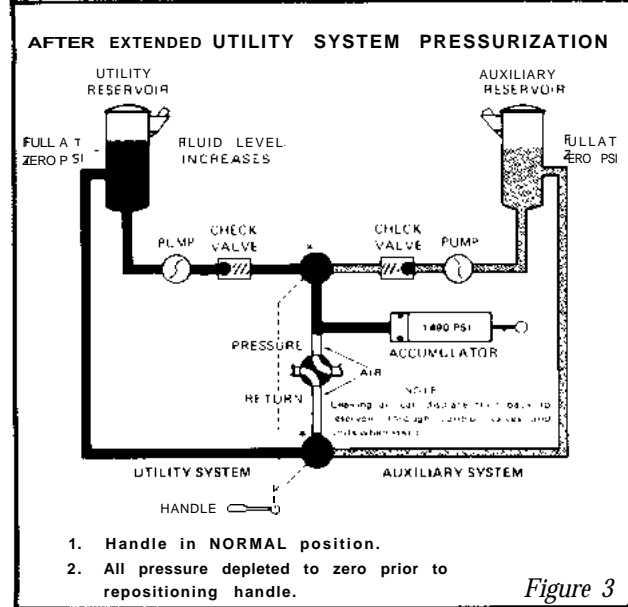
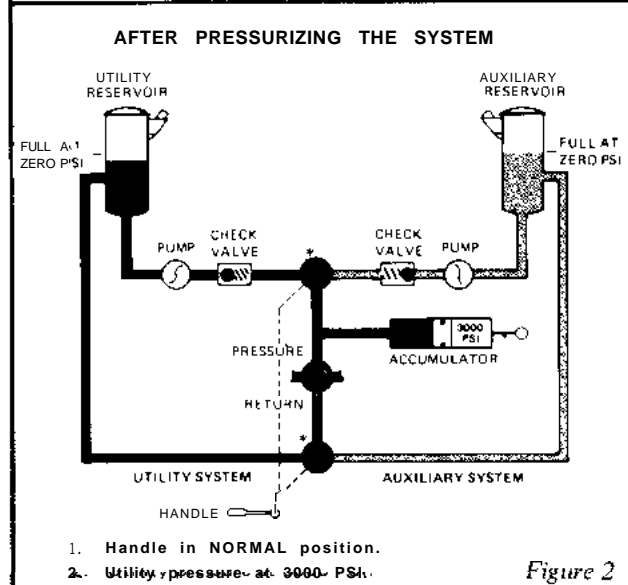
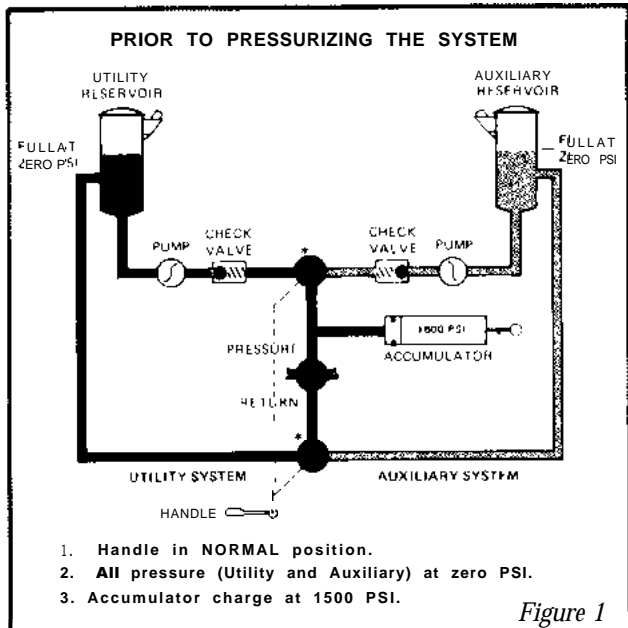

The article in *Service News* Vol. 2, No. 4 October-December 1975 entitled "Hercules Hydraulic System Interconnect Valve Positioning Procedure" included a Troubleshooting Check List that itemized six (6) components that should be checked in the event that fluid was being interchanged between the auxiliary and utility reservoirs. When Harold Chapman (M/Sgt, USAF Ret.), now working for Lockheed as a hydraulic mechanic on C-130's in Saudi Arabia, read the article he told us something we did not know. He said, that in addition to the six components we listed, a leaking accumulator can also cause an interchange of fluid.

# *Hydraulic Fluid between Systems*

Investigation revealed that Harold was indeed right. If the piston seal is worn or damaged, air can leak from the pressurized air side of the accumulator, across the floating piston, and into the fluid side of the accumulator. If the system pressure is zero, pressure on the air side will be 1500 PSI and pressure on the fluid side will be zero (Figure 1). When leakage occurs, the air will enter the hydraulic lines where it will expand and displace the fluid normally in the lines (Figure 3).

The utility system and normal brake accumulators are the ones which, if leaking air across the piston, can cause a fluid interchange. This fluid will normally transfer from the auxiliary to the utility reservoir - this is true only because the interconnect valve handle is usually in the NORMAL position. In this position air leaking from the above mentioned accumulators will seep into the utility return lines and displace fluid which will return to and overflow the utility reservoir.

The actual transfer of fluid occurs when the utility system is pressurized with the auxiliary pump (Figure 4). Fluid pumped from the auxiliary reservoir goes to fill the

\* INTERCONNECT VALVE  
 REPRESENTATIVE OF CONTROL VALVES  
 FOR UNITS OF THE HYDRAULIC SYSTEM



partially empty (of fluid) utility system lines; if the interconnect valve handle is then repositioned to normal, this fluid is lost forever to the auxiliary reservoir and added to the utility system (Figure 6).

Although transfer will usually be from auxiliary to utility, the transfer can occur in the utility to auxiliary direction. This will occur when air leaks from the utility system or normal brake accumulator while the interconnect valve handle is in the interconnect position. In this mode, air from the above mentioned accumulators can leak into the auxiliary system lines displacing fluid and overfilling the

# Interchange

by John Walters,  
Design Engineer, Senior

auxiliary reservoir. Subsequent repositioning of the interconnect valve to the normal position and pressurization by the utility system pumps will draw fluid from the utility reservoir to displace the air in the lines. This fluid will then be lost forever from the utility reservoir.

Checking for an air leak at the accumulator requires careful observation. The gage is so small that a change of 12 PSI is hardly discernible, yet this can cause 38 cubic inches of fluid to be transferred. This would result in a one inch rise in fluid level in the reservoir.

Leakage from the accumulator air side does not necessarily mean that the leakage is occurring across the floating piston. Leakage can be occurring externally at the air charger valve. If you have to periodically recharge the accumulator, check for external leakage with soap solution. If no external leakage is found, then change the accumulator.

**SERVICE NEWS**

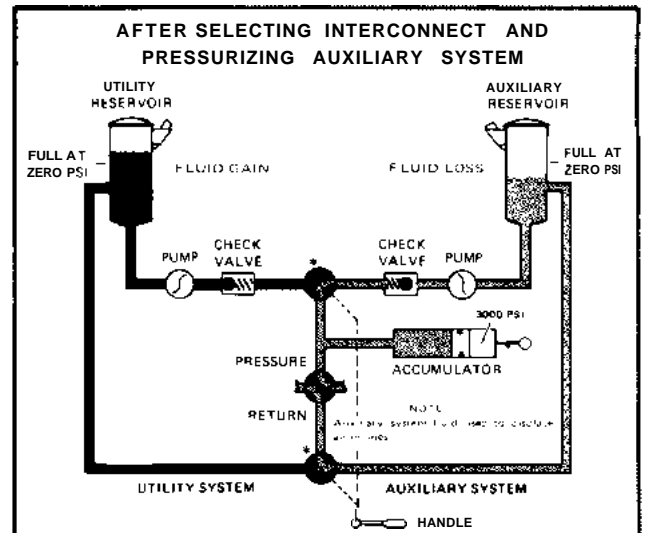

Figure 4  
1. Handle in INTERCONNECT position.  
2. Auxiliary system pressurized to 3000 PSI.

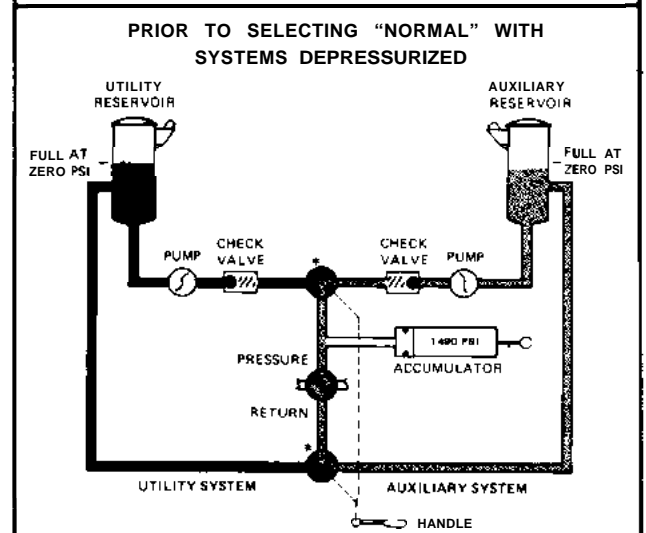

Figure 5  
1. Handle in INTERCONNECT position.  
2. Both systems depressurized.

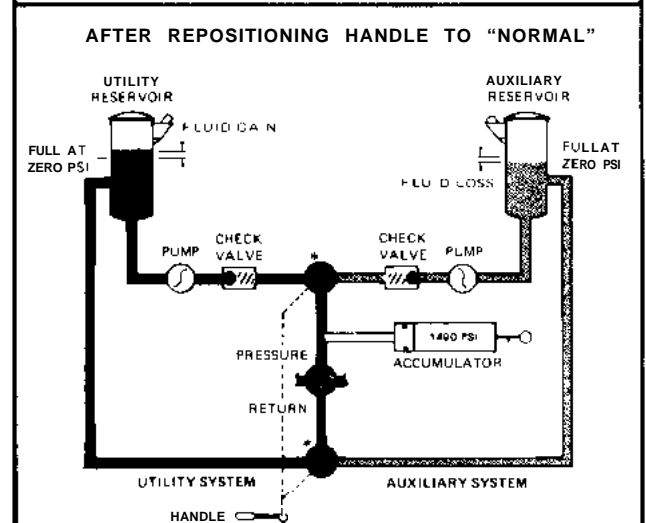



Figure 6  
1. Handle in NORMAL position.  
2. All pressure at zero PSI.

\* INTERCONNECT VALVE  
 REPRESENTATIVE OF CONTROL VALVES FOR UNITS OF THE HYDRAULIC SYSTEM

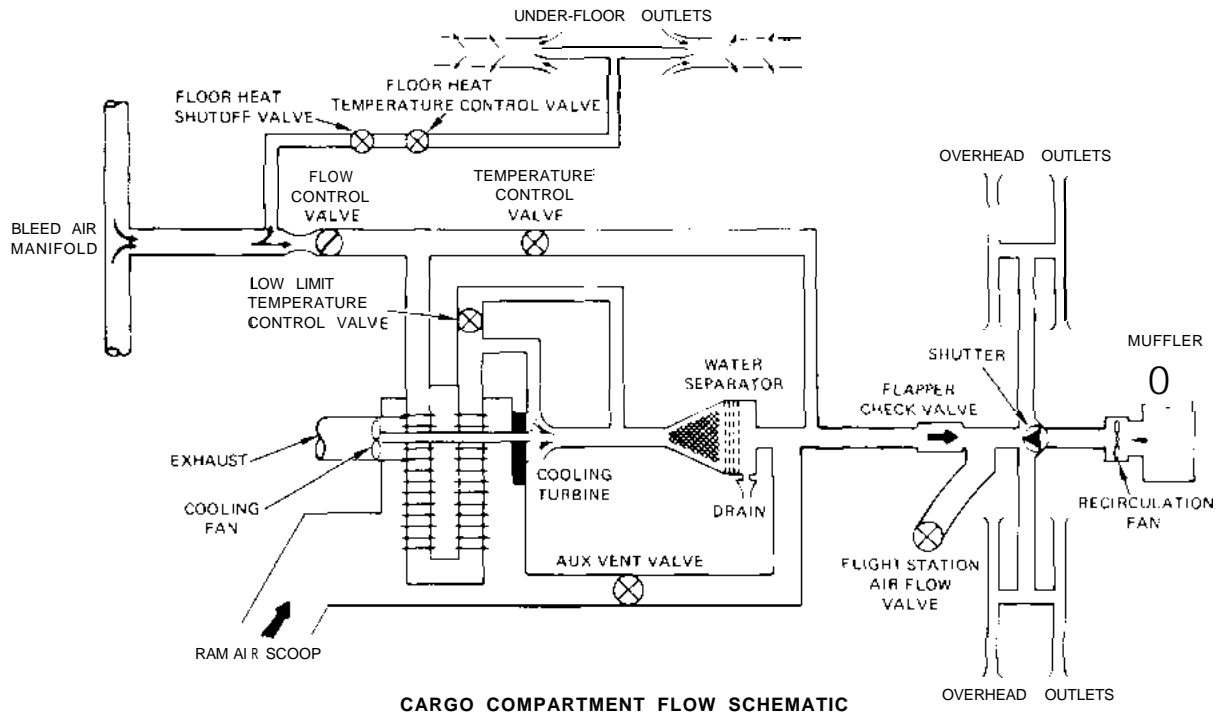

Figure 1

# Hercules WW Air Conditioning

In the last issue of the *Service News*, we discussed the Hercules air conditioning system up through LAC Serial 4652. This included the latest transistorized temperature control system, but not the new refrigeration package and APU. Beginning with LAC Serial 4653, new refrigeration packages are installed and an Auxiliary Power Unit (APU) replaces the Gas Turbine Compressor (GTC) and Air Turbine Motor (ATM). First, let's discuss the changes in the air conditioning system; then, in a later issue, the APU.

## REFRIGERATION PACKAGES

The cargo compartment and the flight deck compartment packages are both 70 pound-per-minute (PPM) units. A look at the simplified flow schematic for each system (Figures 1 and 2) will show that they are basically the same for airflow and temperature control. The cargo compartment system air is delivered to the overhead outlets, and the flight station air is delivered to the crew member and defogging outlets. Since the flight station unit capacity now matches that of the cargo compartment unit, some of the flight station air



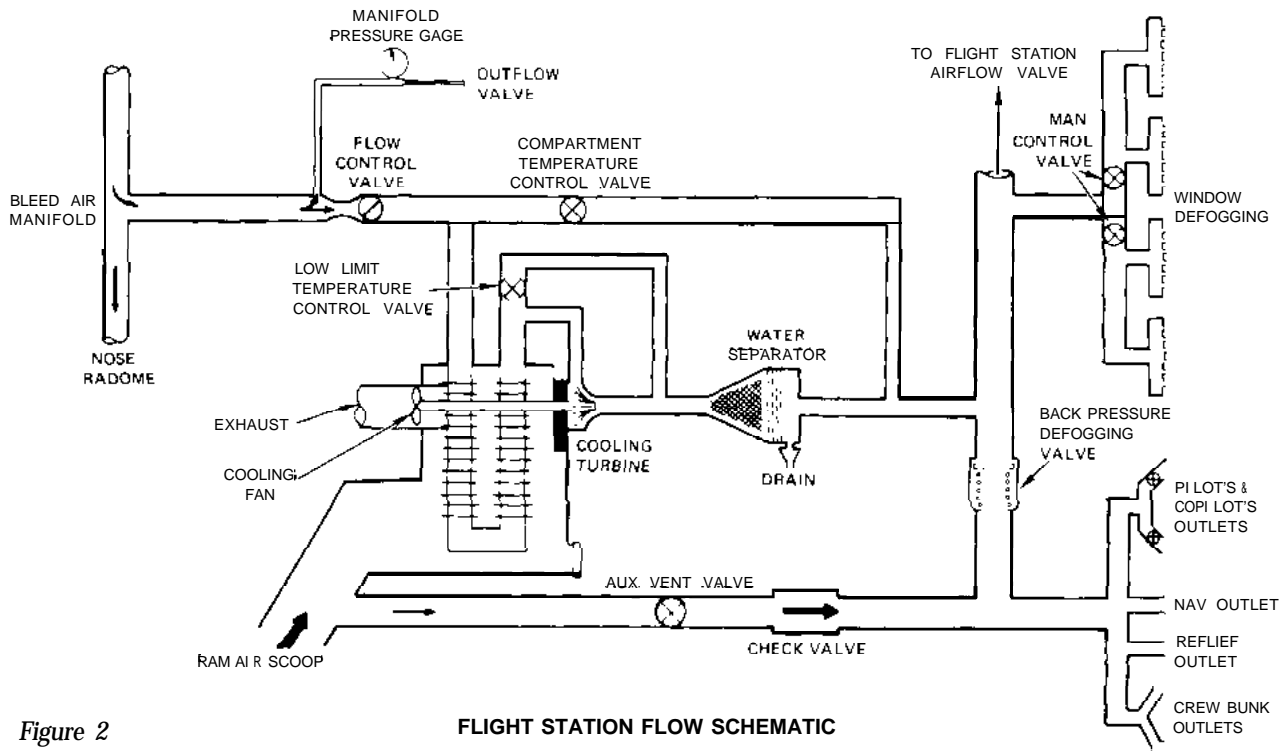

Figure 2

FLIGHT STATION FLOW SCHEMATIC

# Units

can be diverted to the cargo compartment as needed. Also, the loss of the cargo compartment unit does not compromise pressurization as with the old system. Now the flight station unit has the flow capacity to maintain pressurization.

Figure 3

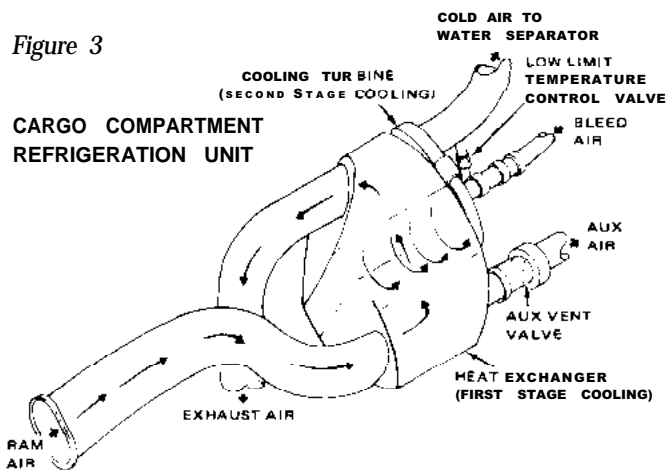

The new refrigeration packages consist of two stages of cooling (see Figure 3). The first stage is an air-to-air heat exchanger; the second stage is a high-speed cooling turbine. Hot air enters the heat exchanger and is diffused into a series of thin-walled fin-plate passages. Outside air from the ram air scoop circulates across the fin plate passages. Heat from the bleed air is transmitted through the walls of the plates and is carried overboard by the outside (ram) airflow. Unlike the older system where only a portion of the ram air passed through the fan, all of the

ram air flowing through the new units passes through the fan. During ground operation, this permits more cooling air flow across the heat exchanger, which, along with the more efficient heat exchanger, results in better airplane cooling.

COOLING TURBINE (Figure 4)

The cooling turbine is an integral part of the refrigeration package. After the hot bleed air has passed through the heat exchanger, it is directed to the turbine wheel. The warm, high pressure bleed air drives the turbine wheel which, in turn, drives the fan. In driving the turbine, the bleed air gives up heat energy. Further cooling of the air takes place as the bleed air is discharged from the turbine into the outlet duct and allowed to expand. The total heat loss can result in discharge air below freezing. This air is directed through the water separator and into the air conditioning ducts.

Figure 4

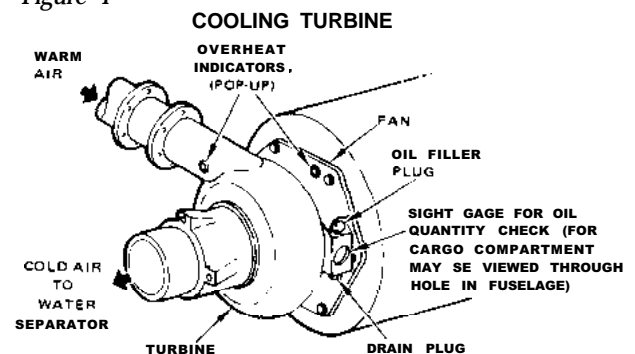

## WATER SEPARATORS (Figure 5)

As the air is cooled, its capacity for water vapor is lowered, and moisture condenses on the water separator bag. Ice can form in the water separator and block the flow of air. With the new package, the formation of ice is prevented by the low limit temperature control valve and its control system. A sensor located near the water separator outlet senses the temperature. If the temperature at the water separator should be above approximately 41°F (5°C), the signal from the sensor through the low limit temperature control box drives the low limit valve toward CLOSE. If the temperature drops to or below approximately 35°F (2°C), the valve moves toward OPEN, permitting warm air to bypass the turbine and warm the air entering the water separator.

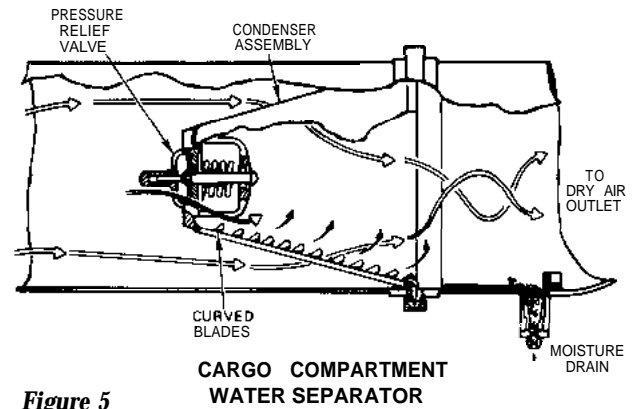

Figure 5

VENT, OFF, NO PRESS, AUTO PRESS, and MAN PRESS.

## TEMPERATURE CONTROL (Figure 6)

The selected cabin temperature is maintained by the transistorized temperature control system positioning the Temperature Control Valve to mix hot air, which is permitted to bypass the refrigeration package, with turbine discharge air, which, as we have seen, can be quite cold. This temperature control valve replaces the dual control valve used previously.

## CONTROL PANEL (Figure 7)

20

There has been a change to the Air Conditioning Master Switch. The new master switch has five positions: AUX

A new switch, FLT STA AIRFLOW, has been added to control flight station air flow. Its positions are: MIN, NORMAL, INTMED, and MAX (see Figure 8).

This switch controls a flow diverter valve located on the aft side of FS 245 bulkhead.

When the FLT STA AIRFLOW switch is in the MIN (minimum) position, the diverter valve is open and the flight station receives minimum airflow, with most of the air going to the cargo compartment. In the NORMAL position, the valve is 80% closed and the flight station receives most of the air, the rest going to the cargo compartment. INTMED (intermediate) positions the valve

Figure 6

## TEMPERATURE CONTROL SCHEMATIC

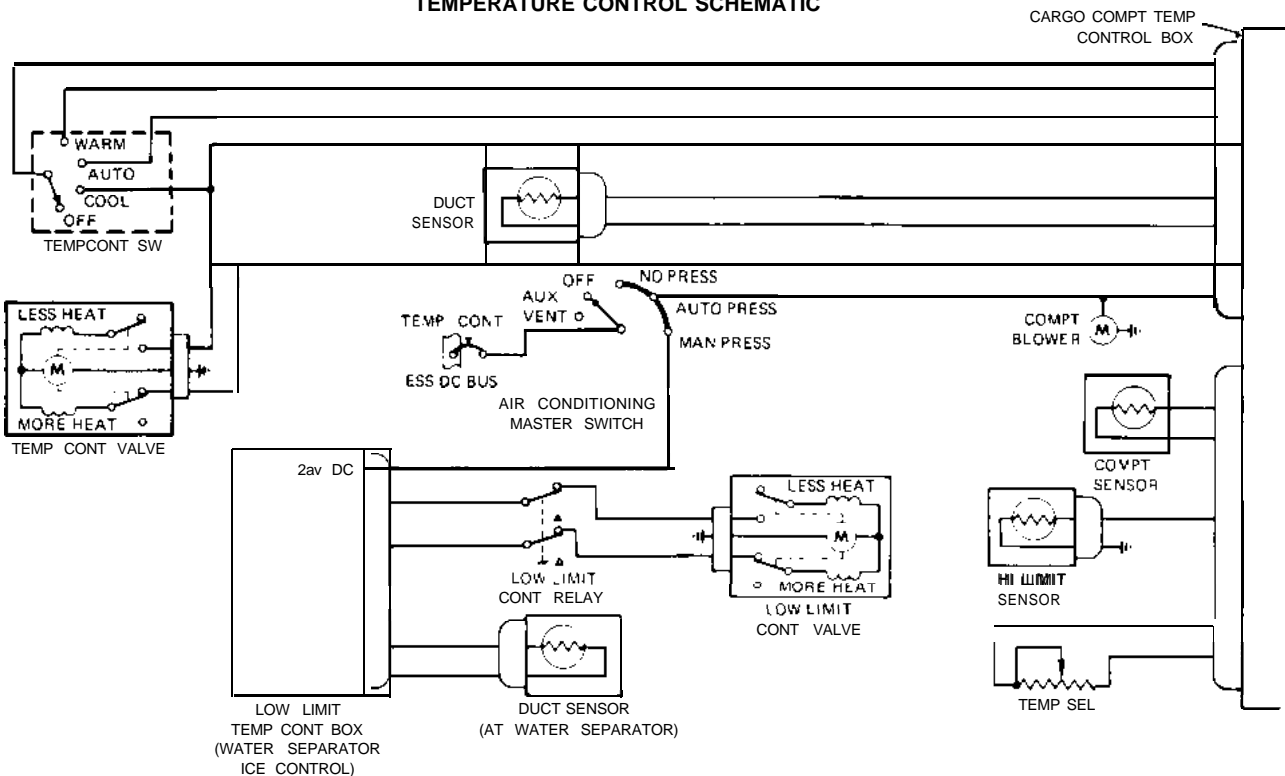

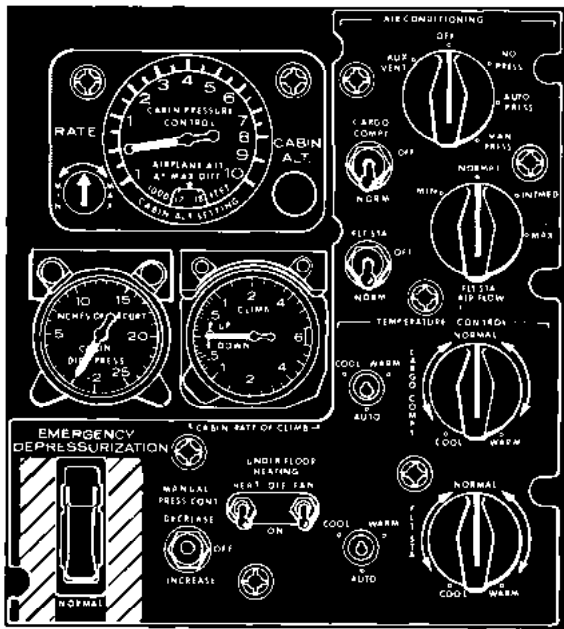

Figure 7

to direct approximately 60% of the air to the flight station. Maximum flow to the flight station is obtained with the switch in MAX, which closes the diverter valve.

### BLEED AIR PRESSURE REGULATOR AND SHUTOFF VALVE

Beginning with LAC Serial 4579, a new Bleed Air Pressure Regulator and Shutoff Valve is installed. There is one

valve per engine, located in the bleed air duct leading from each engine to the wing bleed air manifold. Located aft of the firewall, the valve is a solenoid-controlled, pneumatically-actuated, spring-loaded closed, butterfly type. It incorporates position feedback for flow-sharing accuracy and other features for fully-open non-regulating operation and reverse airflow through the valve. It can regulate flow at approximately 50 PSI, or can be operated in the full open, non-regulating position. Control is through a three position switch (see Figure 9). Manual wrenching is provided to open the valve and lock the butterfly in the open position.

**Regulating** - Normal operation is bleed airflow from the engine to the wing manifold. With the Engine Bleed Air Switch in the ON position, the valve will be regulating flow at approximately 50 PSI. Valve operation is as follows (refer to Figure 10):

- With the switch ON, solenoid A is energized, B is deenergized.
- Upstream air pressure passes through the filter, through the shuttle, and to solenoid A which is open, then to the open side of the valve actuator diaphragm, causing the valve to start opening. The Bleed Off Regulator reduces the pressure to a constant value for valve operation

Figure 8

### AIR CONDITIONING CONTROL SCHEMATIC

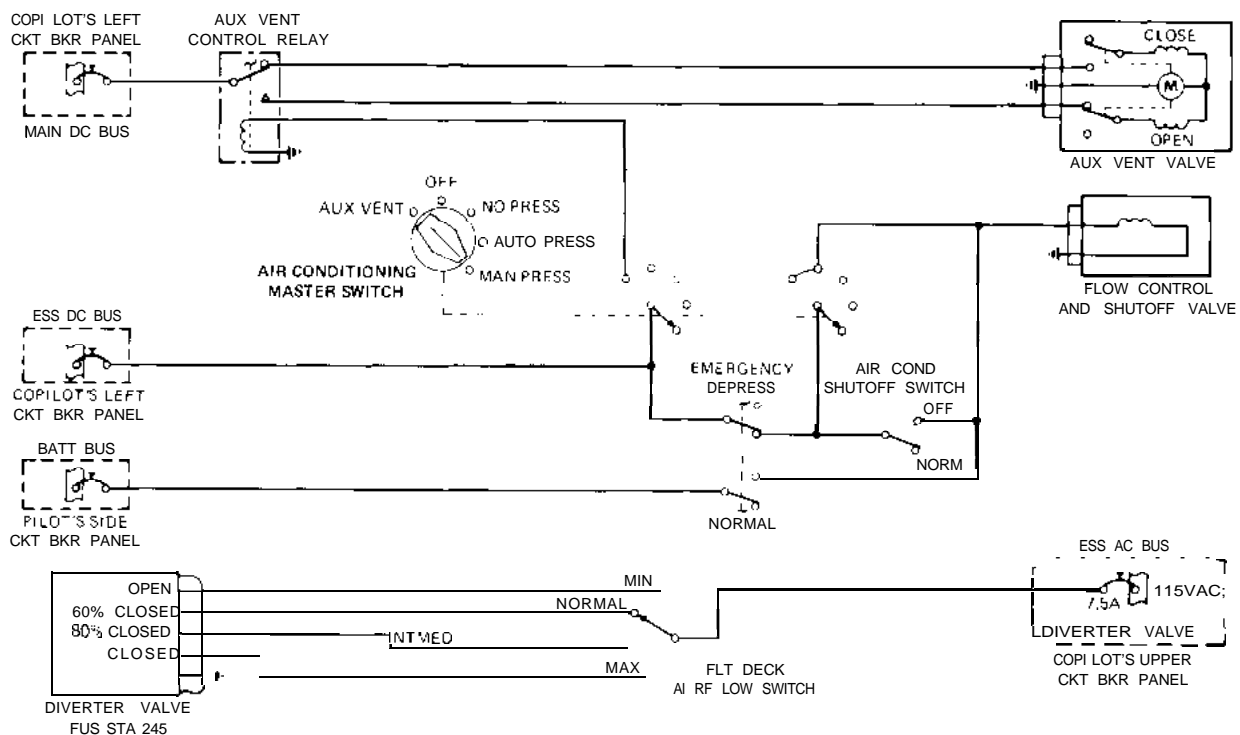

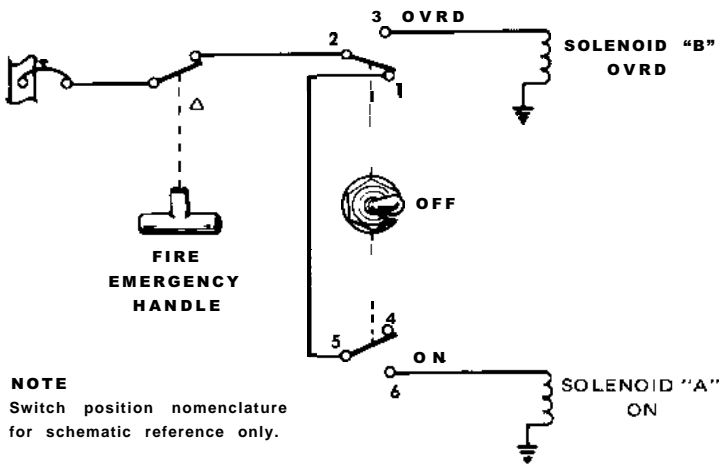

**NOTE**  
Switch position nomenclature for schematic reference only.

**BLEED AIR PRESSURE REGULATION VALVE**

Figure 9

- As the valve opens, down stream pressure increases. This pressure buildup is sensed in the servo which, working against spring tension on the feedback spring, positions the valve blocking the metering nozzle. If the opening of the metering nozzle is increased, the pressure from the open side of the actuator diaphragm is bled off through the deenergized solenoid B. This permits the spring to move the butterfly toward closed.
- It is the balance of pressure maintained by the feedback spring and metering nozzle that regulates the valve position. If downstream pressure increases enough to overcome the feedback spring, the metering nozzle bleeds off more pressure, permitting the butterfly valve to move toward closed.

22

- As downstream pressure tends to decrease, the feedback spring overcomes the servo action, closes off the metering nozzle, and allows less pressure to bleed off. This increases the pressure on the open side of the butterfly valve actuator, moving the butterfly toward open. This is the regulating action, set for approximately 50 PSI.
- During regulating operation, there is a "sharing of the load." Each valve butterfly seeks a position that balances the bleed load on each engine. The actual regulated pressure varies (droops) as load is applied to provide flow sharing between engines.

**Non-Regulating** - For non-regulating airflow, such as during engine starting, the valve is fully open. This operation is controlled by placing the control switch in OVRD (over-ride) position (refer to Figure 11).

- Solenoid A is deenergized, solenoid B is energized.
- During engine start, air pressure from the wing bleed air duct is sensed through the downstream sense line, through the shuttle (which shifts position from the one previously shown), through the open solenoid B, to the open side of the actuator diaphragm, moving the butterfly valve to open.
- Again, the Bleed Off Regulator protects the diaphragm by bleeding off some of the pressure.

Figure 10

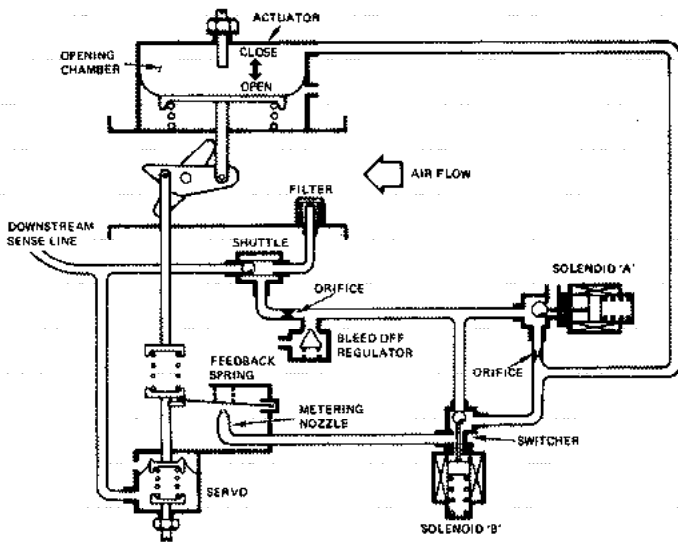

**BLEED AIR PRESSURE REGULATION VALVE (REGULATING)**

Figure 11

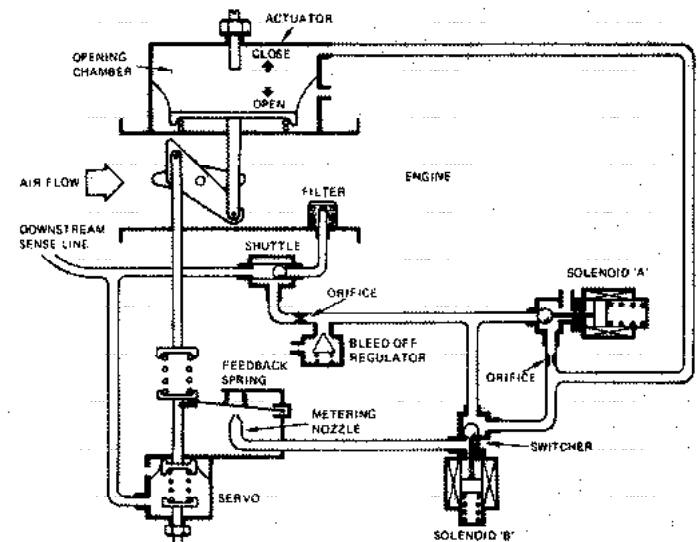

**BLEED AIR PRESSURE REGULATION VALVE NON REGULATING (ENGINE START)**

- With solenoid B energized, the metering nozzle is effectively removed from the system. There is no regulating action – the valve stays fully open.
- With the engine furnishing bleed air pressure (after start), the valve can be operated in the OVRD position. Engine bleed air will pass through the filter, shift the shuttle valve, and open the valve fully, as in the foregoing operation.

Close – To close the valve, place the switch in OFF. Both solenoids will be deenergized. When solenoid A is deenergized, the open side of the actuator diaphragm is vented to atmospheric pressure, permitting the actuator spring to close the valve (see Figure 12).

#### SUMMARY

The new air conditioning units have improved system efficiency. Ground cooling is greatly enhanced with the increased cooling capacity of the new heat exchangers. Water separator anti-icing and overall temperature control are improved with the low limit temperature control

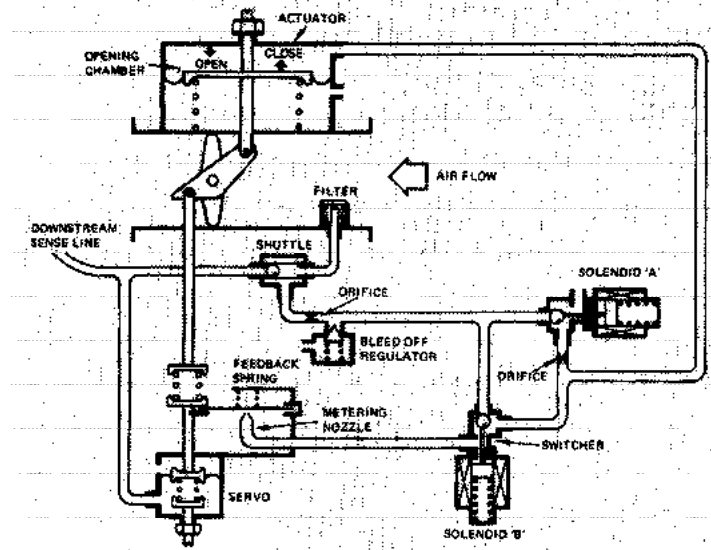

Figure 12

**BLEED AIR PRESSURE  
REGULATION VALVE (CLOSED)**

valve, the temperature control valve, and the transistorized temperature control box. Last, but not least, pressurization can be maintained with either the cargo compartment or the flight deck compartment system operating.



### First Aid for the Hercules Temperature Control System

Periodically inspect and clean the system thermostats. The temperature sampling blower continuously moves cabin air over the exposed mercury bulb and large deposits of lint can collect on the upstream side of the bulbs. This collection can act as an insulator, reducing the sensitivity of the thermostat to temperature changes. Clean the thermostat with a suitable solvent.

The sampling blower impeller can also collect a lint substance, impairing blower operation and possibly causing an unbalanced condition resulting in excessive bearing and brush wear. Cleaning the blades will help increase the useful life of the motor.

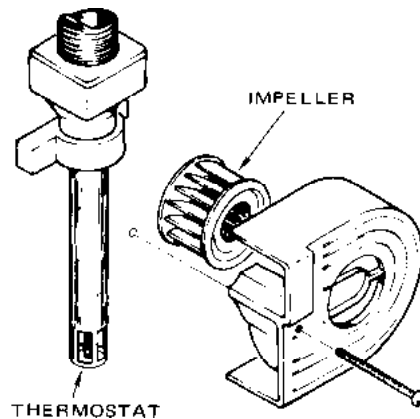

**TYPICAL TEMPERATURE SAMPLING BLOWER**

CUSTOMER SERVICE DIVISION  
LOCKHEED-GEORGIA COMPANY  
A DIVISION OF LOCKHEED AIRCRAFT CORPORATION  
MARIETTA, GEORGIA 30063

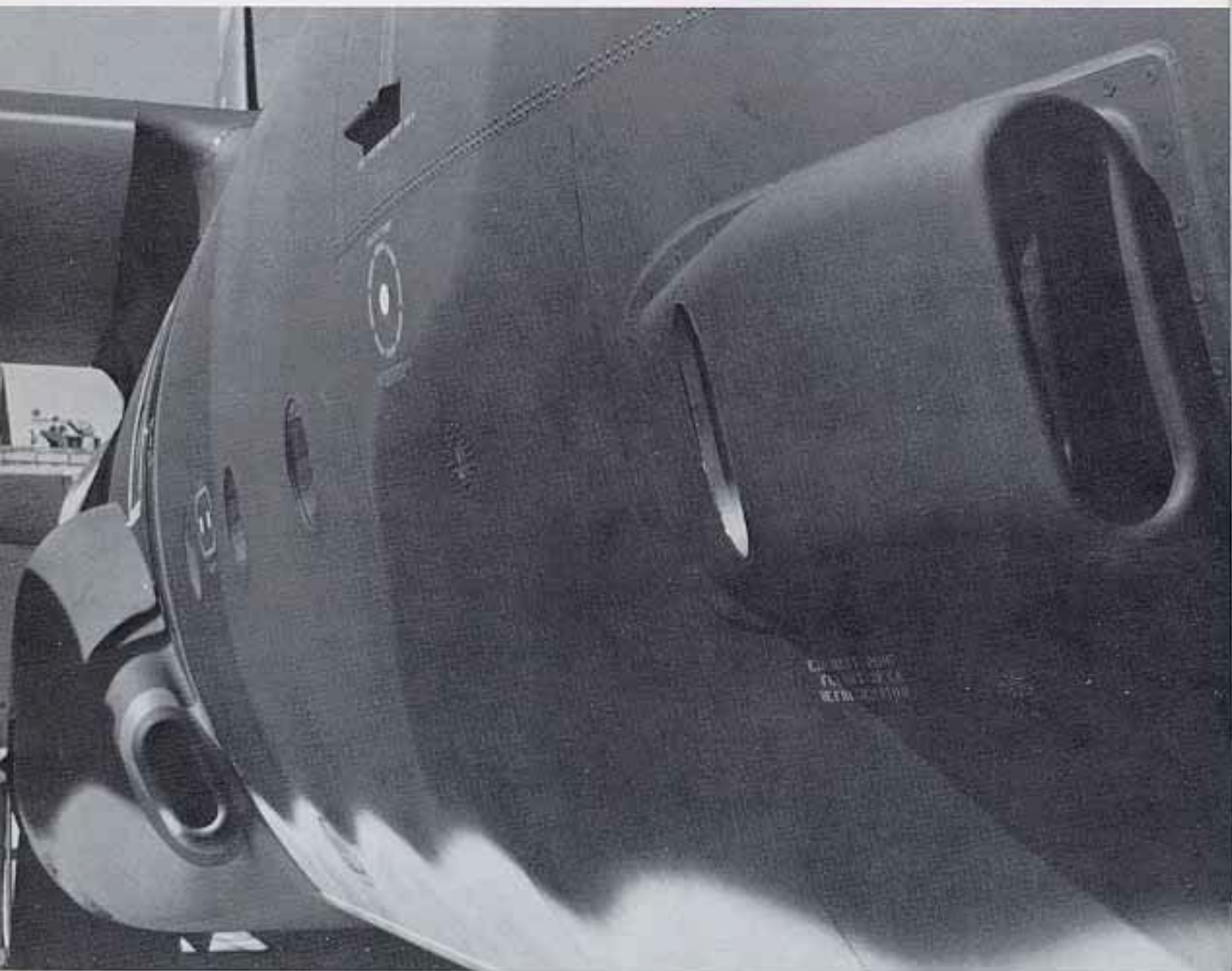

SEE ARTICLE ON PAGE 18

## **Hercules NEW**

# **Air Conditioning Units**