



VOL. 4, NO. 1, JANUARY – MARCH 1977

# *SERVICE NEWS*

A SERVICE PUBLICATION OF LOCKHEED-GEORGIA COMPANY, A DIVISION OF LOCKHEED AIRCRAFT CORPORATION



***Cargo Ramp Rigging***



# SERVICE NEWS

A SERVICE PUBLICATION OF  
LOCKHEED-GEORGIA COMPANY  
A DIVISION OF  
LOCKHEED AIRCRAFT CORPORATION

*Editor*

Jay V. Roy

*Associate Editors*

Don H. Hungate

James A. Loftin

*Art Direction & Production*

Anne G. Anderson

---

## SERVICE NEWS



Cargo Ramp Rigging

Cover: **The Hercules in a demonstration of the Low Altitude Parachute Extraction System (LAPES). With the use of this system, as much as 18 tons of supplies can be delivered in an area about the length of a football field.**

---

Published by Lockheed-Georgia Company, a Division of Lockheed Aircraft Corporation. Information contained in this issue is considered by Lockheed-Georgia Company to be accurate and authoritative; it should not be assumed, however, that this material has received approval from any governmental agency or military service unless it is specifically noted. This publication is for planning and information purposes only, and it is not to be construed as authority for making changes on aircraft or equipment, or as superseding any established operational or maintenance procedures or policies. The following marks are registered and owned by Lockheed Aircraft Corporation: "Service News", "Lockheed", "Hercules", and "JetStar". Written permission must be obtained from Lockheed-Georgia Company before republishing any material in this periodical. Address all communications to Editor, Service News, Department 64-22, Zone 278, Lockheed-Georgia Company, Marietta, Georgia 30063. Copyright 1977 Lockheed Aircraft Corporation.

Vol. 4, No. 1, January – March 1977

## CONTENTS

- 3 **Cargo Ramp Rigging**
- 4 System Requirements
- 15 Ramp Hook Test
  
- 18 **Hercules Flap System**
  
- 22 **An Upcoming Product Improvement**  
New Fuel Quantity Tank Probes
  
- 23 **Troubleshooting Engine Start Problems**
  
- StarTips**
  
- 17 Don't Slam the Door
  
- 22 Oil Pressure Transmitter Vent Line  
on JetStar Engines

**DIRECTOR**

**T.J. CLELAND**

**MANAGER**

**D.L. BRAUND**

**FIELD SERVICE & INVENTORY MGMT**

**A.H. McCRUM**

**CUSTOMER TRAINING**

**E. L. PARKER**

**JETSTAR SUPPORT**

**H.L. BURNETTE**

**SPARES STORES & SHIPPING**

**J.K. PIERCE**

**MANAGER**

**M.M. HODNETT**

**SUPPLY PROCUREMENT**

**R.C. WEIHE**

**SUPPLY SYSTEMS & INVENTORY CONTROL**

**C.K. ALLEN**

**SUPPLY SALES & CONTRACTS**

**H.T. NISSLEY, JR.**

**SUPPLY TECHNICAL SUPPORT**

**J.L. THURMOND**

# CARGO RAMP RIGGING

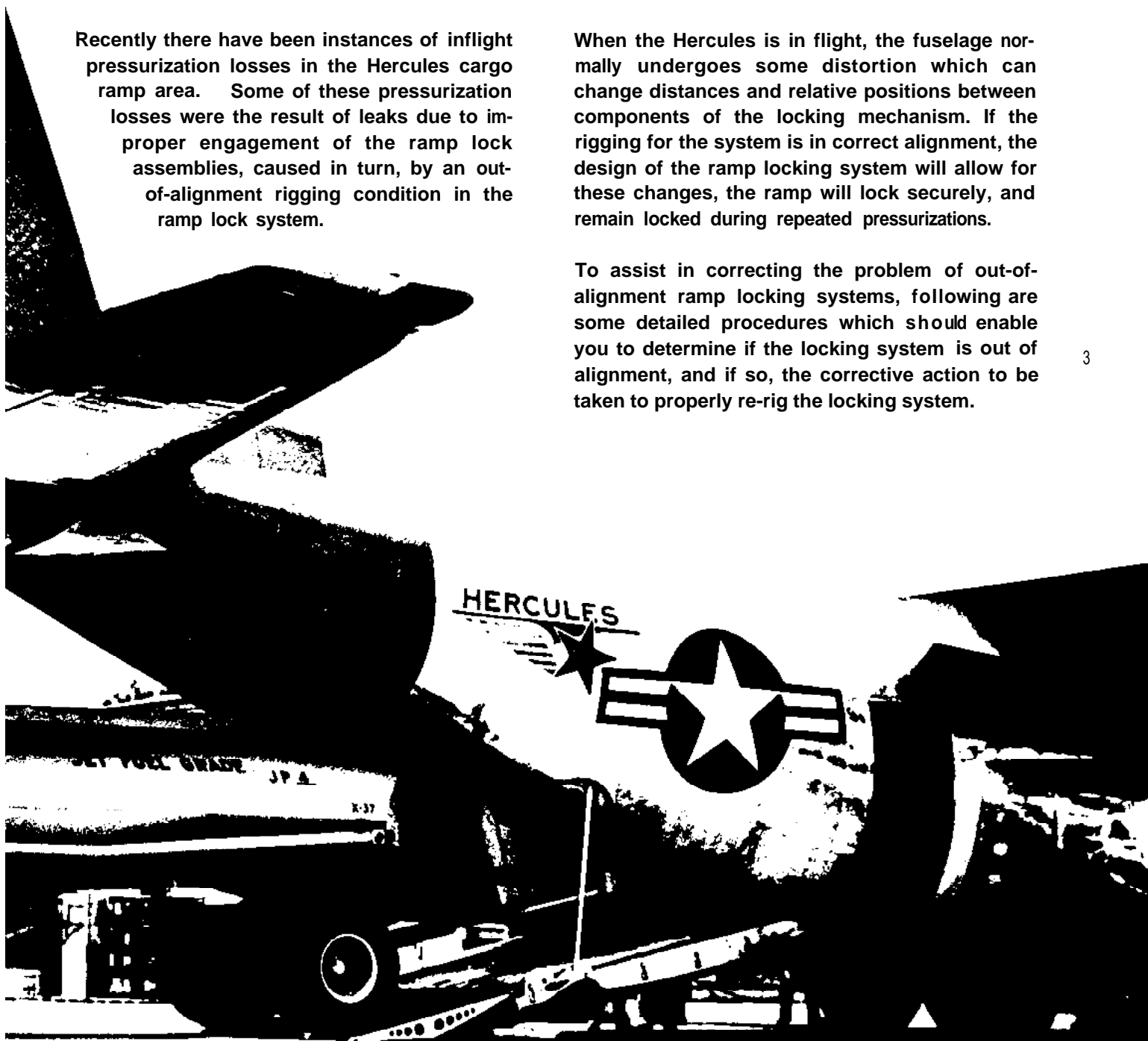
by R. W. (Bob) Nazarowski, *Senior Structures Design Engineer*

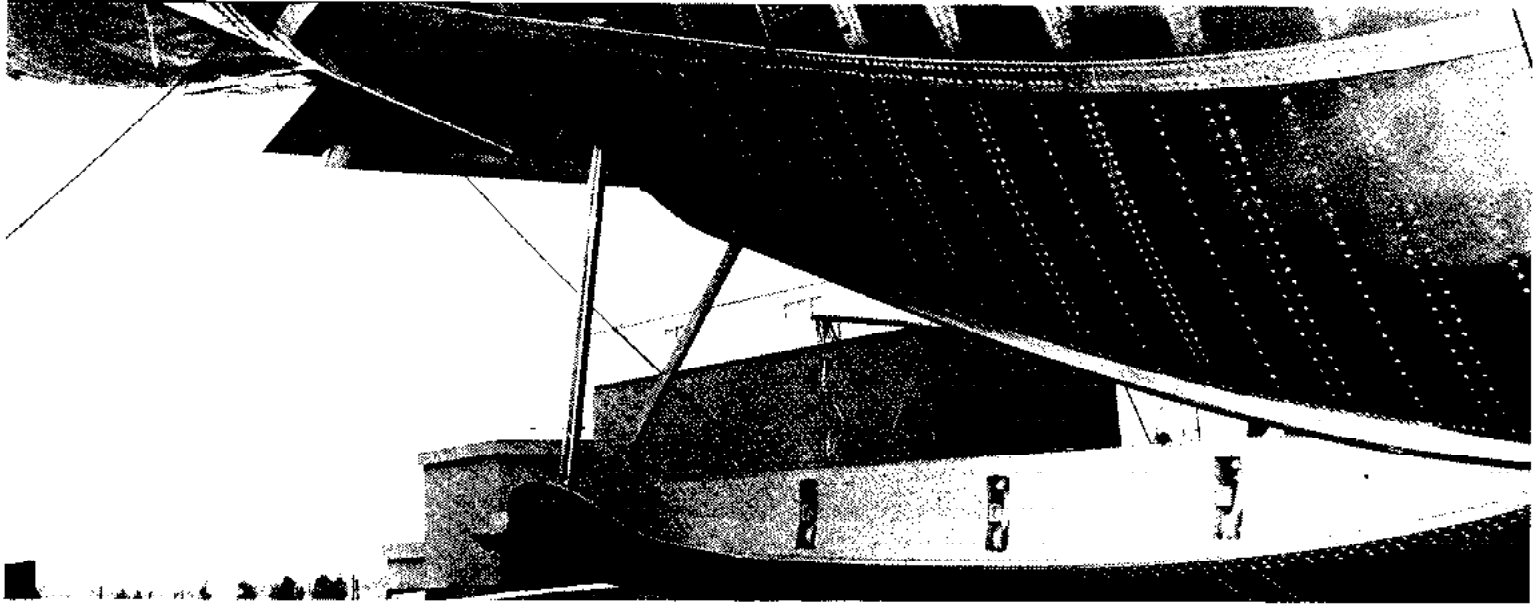
Recently there have been instances of inflight pressurization losses in the Hercules cargo ramp area. Some of these pressurization losses were the result of leaks due to improper engagement of the ramp lock assemblies, caused in turn, by an out-of-alignment rigging condition in the ramp lock system.

When the Hercules is in flight, the fuselage normally undergoes some distortion which can change distances and relative positions between components of the locking mechanism. If the rigging for the system is in correct alignment, the design of the ramp locking system will allow for these changes, the ramp will lock securely, and remain locked during repeated pressurizations.

To assist in correcting the problem of out-of-alignment ramp locking systems, following are some detailed procedures which should enable you to determine if the locking system is out of alignment, and if so, the corrective action to be taken to properly re-rig the locking system.

3





## SYSTEM REQUIREMENTS

The cargo ramp locking system is adjusted and operating properly when the following requirements are met:

1. Actuator bellcrank conforms to the no gap requirements of Step II.
2. With the ramp down and the mechanism in the full locked position, all hook bellcranks conform to the 0.00" to 0.03" gap requirements shown in Figure 5.
3. All ten ramp hooks conform to the maximum hook extension requirements of Step VI.
4. All ten hooks conform to the hook movement requirements and minimum spring force requirements of Step VI I.
5. The hook positioning rod meets the 0.01" to 0.06" gap requirement of Step XV.
6. The fabric patches on the ramp cylinder fittings meet the imprint requirements of Step XVIII. When checking inservice aircraft, replace the fabric patches per Step XVI I I to attain a current imprint of the phenolic stop.
7. The hook retainers meet the distance requirements of Steps XX and XXI.

8. The hook retainers meet the 0.00" and 0.01" to 0.06" gap requirements of Step XXIV.
9. The switches meet the overtravel requirements of Steps XIV, XXV, XXVI, and XXVII.
10. With the aircraft on the ground, the ramp locking pressure is 500 to 1200 PSI (see Step XXI I I).
11. Ramp hook test. If an airplane has previously experienced faulty ramp latching due to an out-of-alignment rigging condition, it is advisable to run this check at the end of the rigging procedure. (See Step XXVI I I.)

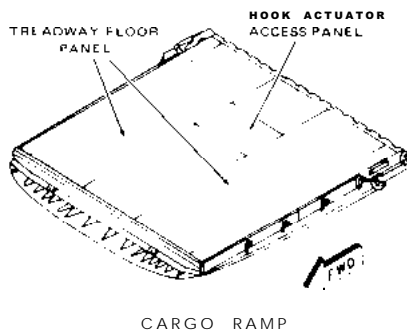


Figure 1

Remove the ramp hook actuator access panel and the ramp treadway panels to gain access to the locking mechanism (see Figure 1).

Mark the control rods, connecting rods, and hook push rods with the location nomenclature shown in Figure 2; and remove the rods. Disconnect the ramp lock positioning rod from the actuator bellcrank. Bag, identify and retain all attachments.

Prior to lubrication, clean all dirt, old grease, and foreign materials from around hooks, bellcranks, and other parts, using I-I -1 trichloroethane (O-T-620) safety solvent or equivalent cleaning material. Lubricate the mechanism per applicable maintenance manual.

Check all hooks, bellcrank assemblies, switches, springs, catches, and the ramp switches to see that they are working freely without binding or interfering with adjacent structure.

Start internal ramp rigging by using the auxiliary system hydraulic hand pump to apply hydraulic pressure to the ramp hook actuator. Move the actuator bellcrank to the locked and unlocked position while checking to see that the actuator bellcrank contacts the actuator bellcrank locked stop (see Figure 3) when the actuator bellcrank is in the **locked position**, and that it contacts the actuator bellcrank **unlocked stop** when the actuator bellcrank is in the **unlocked position**. **No gap is permissible between the stops and the actuator bellcrank, but full contact along the surface of the stop is not required.** If

the installation of the actuator produces a gap between the stops and the actuator bellcrank, make the following checks: (1) Check for an out-of-tolerance actuator or actuator bellcrank. Replace if necessary. (2) Check for mislocation of stops, bellcrank pivot point, or actuator support fitting.

When the actuator bellcrank properly contacts both stops, remove and retain the actuator to actuator-support fitting attachments, and proceed with rigging.

Start rigging of the hook push rods at ramp station 2L (left-hand side) by adjusting the distance between the rod-end centers of the ramp station 2L hook push-rod assembly to the "L" dimension shown in Figure 4.

Whenever adjusting for the "L" dimension, adjust each end of the push-rod assembly so that the distance from the rod-end center to the edge of the jamnut is equal (within +/- 0.06") at each end of the tube (see Figure 4).

Rotate either rod end 1/4 turn, lengthening the rod assembly approximately 0.01". This will position the rod ends for proper installation. Tighten each jamnut to a torque of 95 to 110 inch-pounds.

Insert a 0.063" maximum diameter lockwire in the witness holes, located at each end of the rod assembly (see Figure 4), to ensure that the rod ends have not been overextended. If the lockwire does not contact the rod end threads, make the following checks: (1) Recheck the "L" dimension" (2) Check rod assembly for correct part number (see Figure 4). (3) Dimensionally check parts for out-of-tolerance and replace if discrepant. If the lockwire contacts the rod end threads, the rod end has adequate thread engagement. Proceed with rigging.

Install the rod assembly between the ramp station 2L hook bellcrank and the ramp station 2L rod bellcrank.

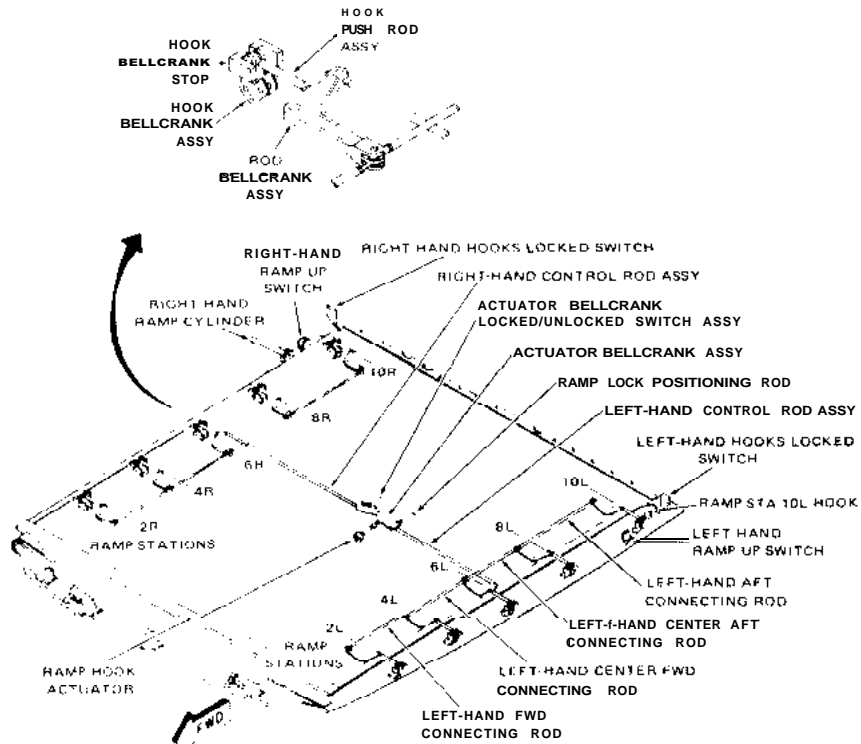


Figure 2 CARGO RAMP

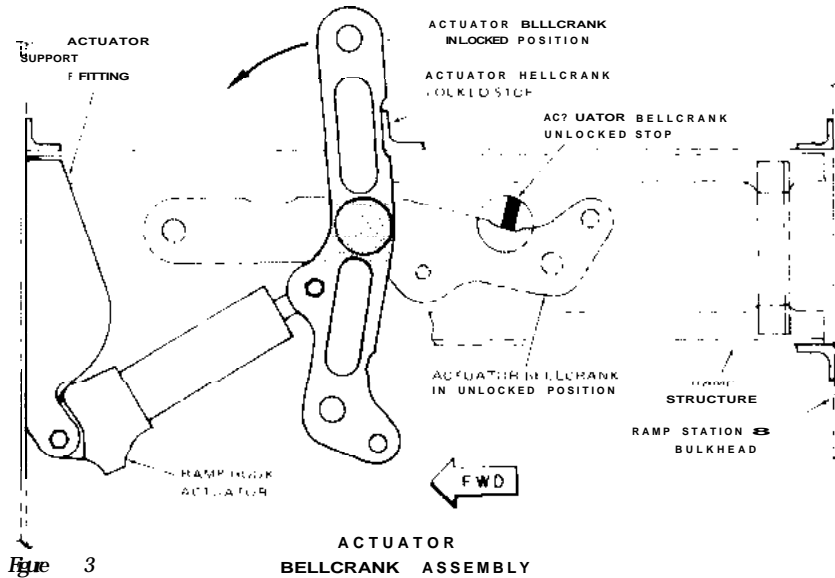
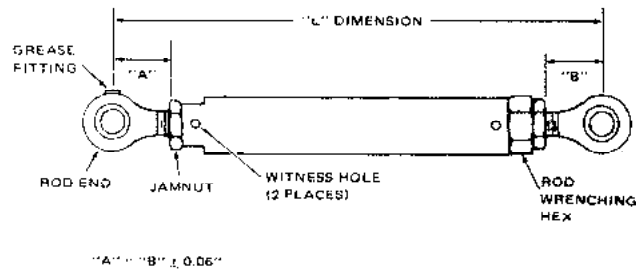


Figure 3 ACTUATOR BELLCRANK ASSEMBLY



REFERENCE PART NO.	NAME	"L" DIM ± 0.03"
341016-502	RAMP STA 2L & 2R HOOK PUSH ROD ASSY	10.06"
341016-502	RAMP STA 4L & 4R HOOK PUSH ROD ASSY	10.06"
341016-501	RAMP STA 6L & 6R HOOK PUSH ROD ASSY	9.27"
341016-502	RAMP STA 8L & 8R HOOK PUSH ROD ASSY	10.11"
341016-502	RAMP STA 10L & 10R HOOK PUSH ROD ASSY	10.08"

Figure 4 HOOK PUSH ROD ASSEMBLY

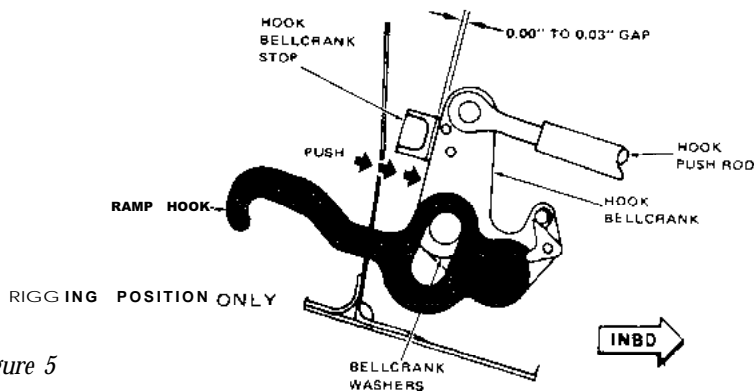


Figure 5

The rod wrenching-hex part of the hook pushrod assembly (see Figure 4) is to be located adjacent to the hook bellcrank; and the grease fitting on the rod end, located adjacent to the rod bellcrank, is to face aft. Install fasteners through the rod ends, tightening nuts only to eliminate end play in the bolt (do not overtighten). Operate the ramp station 2L rod bellcrank. It should move the ramp station 2L hook bellcrank freely, from a position against the ramp station 2L hook bellcrank stop to a position where the ramp station 2L hook is fully retracted. If binding occurs, check for: (1) Interference between the rod end and the clevis of the rod bellcrank. (2) Over-torquing of the rod end bolts. (3) Structural interference. When operation is free, proceed with rigging.

Adjust the hook pushrod assemblies at ramp stations 2R, 4L, 4R, 6L, 6R, 8L, 8R, IOL, and IOR to the "L" dimension shown in Figure 4; and install the rod assemblies in accordance with the procedure defined in Step I II for the ramp station 2L hook push rod – except, install the rods at their respective ramp stations.

The ramp station 10L and IOR hook push rods may be removed as follows: (1) Remove both hook bellcrank stops. (2) Remove the hook bellcrank pivot bolt. Access to the pivot bolts may be obtained by removing the access covers located on the outboard ends of the ramp station 10 bulkhead upper surface. (3) Extract the hook bellcrank outboard with the hook and pushrod attached.

Clamp the actuator bellcrank to the actuator bellcrank-locked stop (see Figure 3).

Temporarily install the left-hand control rod assembly (see Figure 2) between the actuator bellcrank and the ramp station 6L rod bellcrank. Adjust length to attain a 0.00" to 0.03" gap between the ramp station 6L hook bellcrank and the ramp station 6L hook bellcrank stop (see Figure 5).

The gap dimension is to be measured with the upper portion of the hook bellcrank retained in the inboard-most position. Push on the bellcrank, as directed in Figure 5, to remove all backlash from the linkage.

When adjusting the control rod assembly for proper length, adjust each end of the control rod assembly so that the distance from the rod-end center to the edge of the jamnut is equal (within  $\pm 0.06$ ") at each end of the rod assembly (see Figure 6).

Remove the clamp from the actuator bellcrank. Remove the left-hand

control rod, and rotate each rod end 1/2 turn, lengthening the rod assembly approximately 0.04". Tighten each jamnut to a torque of 290 to 410 inch-pounds.

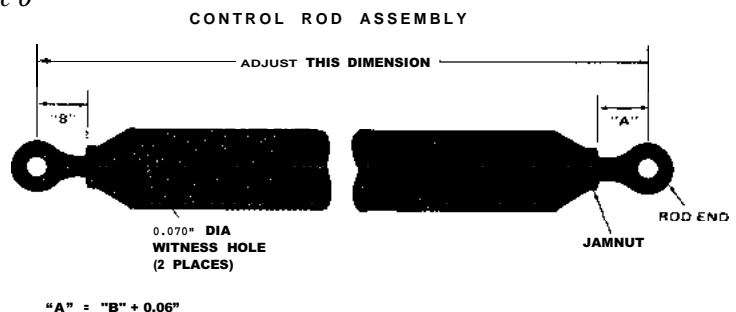
Insert a 0.063" maximum diameter lockwire in the witness holes located at each end of the rod assembly (see Figure 6) to ensure that the rod ends have not been overextended. If the lockwire does not contact the rod end threads, make the following checks:

- (1) Check to see that the actuator bellcrank was properly clamped to the actuator bellcrank-locked stop.
- (2) Recheck "L" dimension on the ramp station 6L hook pushrod.
- (3) Dimensionally check parts for out-of-tolerance and replace if discrepant.

When lockwire contacts the rod end threads, the rod end has adequate thread engagement. Proceed with rigging.

Reinstall control rod. Tighten attachments through the rod ends. First, finger-tighten; then, tighten to the first castellation on the nut (do not overtighten), and install cotter pin. Operate the actuator bellcrank. It should move the ramp station 6L hook bellcrank freely, from the unlocked position (hook up and in the ramp structure) to a point just before the locked position (hook bellcrank against the bellcrank stop), which will be indicated by an increase in resistance to movement of the actuator bellcrank. A light force should be applied to the actuator bellcrank to snap the mechanism over-center to the locked position (see Figure 3). If binding occurs, check for: (1) Interference between the rod

Figure 6



$$"A" = "B" + 0.06"$$

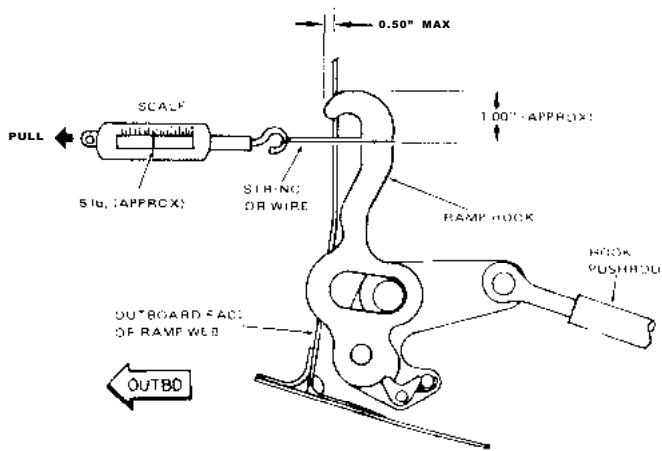


Figure 7 PULL RAMP HOOK OUTBOARD

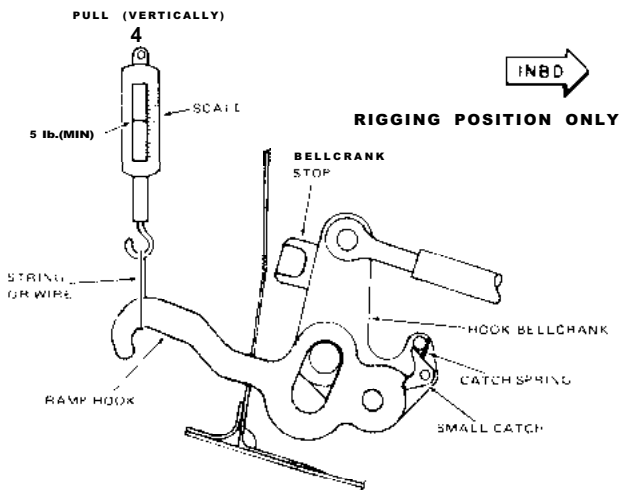


Figure 8 PULL RAMP HOOK VERTICALLY

ends and the bellcrank clevises. (2) Over-torquing of the rod end bolts. (3) Structural interference. When operation is free, proceed with rigging.

Check the ramp station 6L hook for maximum extension requirements per Step VI, and for minimum spring force requirements per Step V II.

Clamp the actuator bellcrank to the actuator bellcrank-unlocked stop (see Figure 3). In the manner indicated in Figure 7, pull the ramp hook outboard with a force of approximately 5 pounds.

If the ramp hook extends beyond the outboard face of the ramp web and exceeds the 0.50" maximum dimension, check for: (1) Correct bolt size in the rod ends of the hook pushrod, connecting rod or control rod. (2) Check for, and replace, out-of-tolerance hook, bellcranks, or rods. When hook extension is 0.50" or less, proceed with rigging.

Clamp the actuator bellcrank to the actuator bellcrank-locked stop (see Figure 3). Check to see that the ramp hook is free to move between the hook bellcrank washers (see Figure 5) without scraping or binding. The hook must be relatively loose between the hook bellcrank washers. If binding occurs, make the following checks: (1) Check areas around the hook and the bellcranks for dirt or foreign materials, or (2) dimensionally check hooks and bellcranks for out-of-tolerance parts (replace faulty components). In the manner indicated in Figure 8, pull vertically on the hook to move the hook up until it contacts the bellcrank.

While pulling the hook up, check the force required to overcome the spring on the small catch located on the lower end of the hook bellcrank (see Figure 8). The proper operation of this small catch is vital for proper locking of the cargo ramp hooks. The function of this catch is to move the lower part of the hook inboard which

will, in turn, move the upper part of the hook outboard with the first movement of the hook bellcrank. This force must be 5 pounds minimum. If this force is less than 5 or more than 15 pounds, make the following checks: (1) Check for, and replace, faulty catch, catch spring, or ramp hook. (2) Check for binding of the hook on the bellcrank washers or binding of the hook pivot point.

if the hook is not free to move between the bellcrank washers or if the force to overcome the catch spring is less than the required 5 pounds minimum, the hook will not move to the correct intermediate locking position as shown in Figure 9; and, as a result, the ramp hook will not properly engage the hook retainer as shown in Figure 10. Instead, the ramp hook will hang up on the lip of the hook retainer, as shown in Figure 11.

Please note the incorrect path of the hook tip as shown in Figure 11. The hook incorrectly moves first down

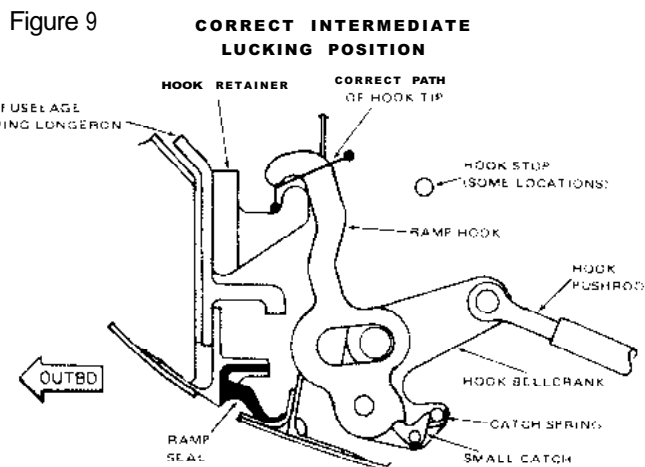


Figure 9

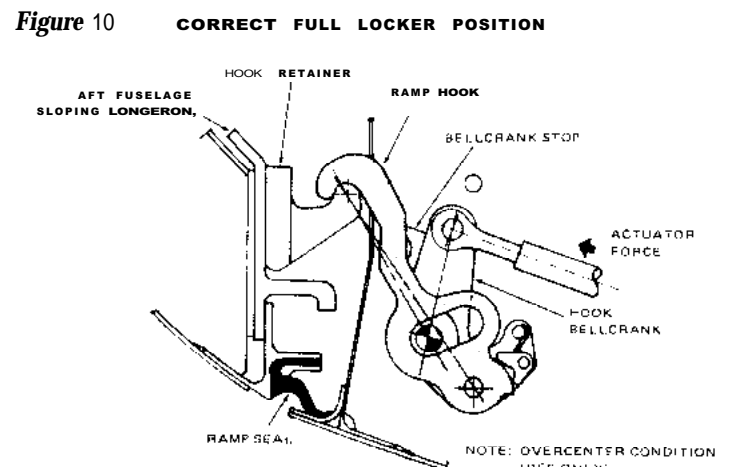


Figure 10

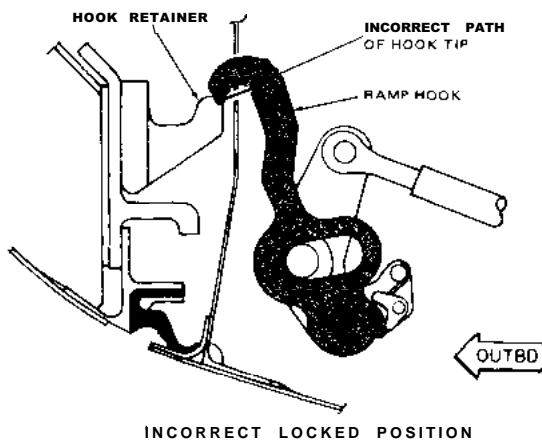


Figure 11

and then outboard, hanging up on the tip of the hook retainer.

The correct path of the hook tip is shown in Figure 9. The hook moves first outboard, clearing the tip of the hook retainer, and then down to the locked position shown in Figure 10.

When the hook moves freely between bellcranks, and the force required to overcome the spring on the small catch is from 5 to 15 pounds, proceed with rigging.

8

Adjust and install the right-hand control rod in accordance with the procedure defined in Step V for the left-hand control rod, except: (1) Install on the right-hand side. (2) Check the ramp station 6R hook for maximum extension requirements in accordance with Step VI, and for minimum spring force requirements as stated in Step VI I.

Clamp the actuator bellcrank to the actuator-locked stop (see Figure 3).

Temporarily install the left-hand, center aft, connecting rod (see Figure 2) in the ramp station 6L rod bellcrank lower clevis, and in the ramp station 8L rod bellcrank Dower clevis. Adjust length of connecting rod to attain a 0.00" to 0.03" gap between the ramp station 8L hook bellcrank and the ramp station 8L hook bellcrank stop (see Figure 5).

The gap dimension is to be measured with the upper portion of the hook

bellcrank retained in the inboard-most position in order to remove all backlash from the linkage.

When adjusting the connecting rod for the proper length, adjust each end of the connecting rod so that the distance from the rod-end center to the edge of the jamnut is equal (within  $\pm 0.06$ ") at each end of the rod assembly (see Figure 12).

Remove the clamp from the actuator bellcrank. Remove the connecting rod and rotate either (but only one) rod end  $1/2$  turn, lengthening the rod assembly approximately 0.02". Tighten each jamnut to a torque of 95 to 110 inch-pounds.

Insert a 0.063" maximum diameter lockwire in the witness holes located at each end of the rod assembly (see Figure 12) to ensure that the rod ends have not been overextended. If the lockwire does not contact the rod end threads, make these checks: (1) Recheck the "L" dimension on the hook pushrod. (2) Dimensionally check parts for out-of-tolerance, and replace discrepant parts. When lockwire contacts the rod-end threads, the rod end has adequate thread engagement. Proceed with rigging.

Reinstall the connecting rod. Install attachments through the rod ends, tightening nuts only to eliminate end play in the bolt (do not overtighten). Operate the actuator bellcrank. It should move the ramp station 8L hook bellcrank freely, from a position against the ramp station 8L hook bellcrank stop (see Figure 8) to a position where the ramp station 8L hook is

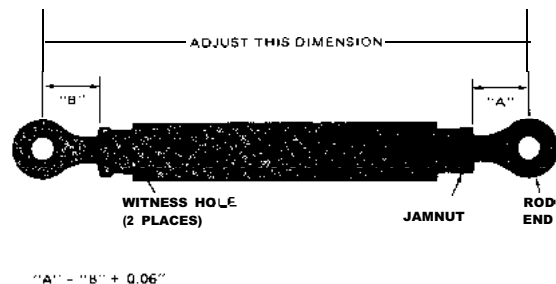


Figure 12

fully retracted (see Figure 13).

If binding occurs, check for: (1) Interference between the rod ends and the bellcrank clevises. (2) Over-torquing of the rod ends. (3) Structural interference. When operation is free, proceed with rigging.

Check the ramp station 8L hook for the maximum extension requirement outlined in Step VI, and for minimum spring force requirements stated in Step VII.

Adjust and install the right-hand, center aft, connecting rod (see Figure 2) in accordance with the procedure defined in Step IX for the left-hand, center aft, connecting rod, except: (1) Install on the right-hand side. (2) Check the ramp station 8R hook for maximum extension requirements in Step VI, and for minimum spring force requirements stated in Step VII.

Adjust and install the right- and left-hand, center forward, connecting rods (see Figure 2) in accordance with the procedure defined in Step IX, except: (1) Install rods between the ramp station 6L/R rod bellcrank upper clevis and the ramp station 4L/R rod bellcrank lower clevis. (2) Adjust gap between ramp station 4L/R hook bellcrank and bellcrank stop, and check movement of the ramp station 4L/R hook bellcranks. (3) After adjusting for the proper gap per item (2) of this paragraph, rotate



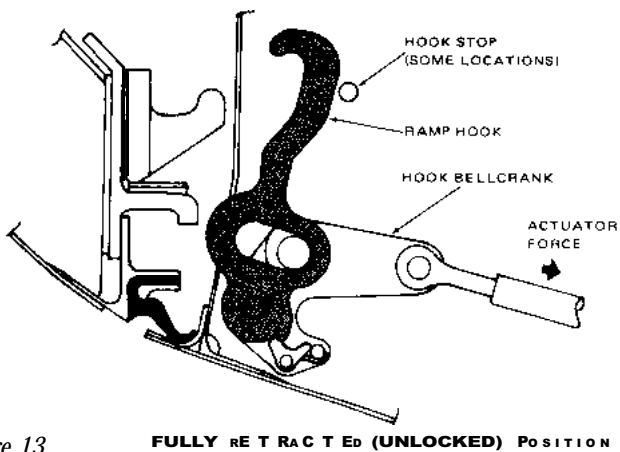


Figure 13

FULLY RETRACTED (UNLOCKED) POSITION

the rod end 1/2 turn, shortening the rod assembly approximately 0.02" in lieu of lengthening as stated in Step IX. (4) Check the ramp station 4L/R hooks for maximum extension requirements defined in Step VI, and the minimum spring force requirements in Step VII.

Adjust and install the right- and left-hand, aft connecting rods in accordance with the procedure defined in Step IX, except: (1) Install rods between the ramp station 8L/R rod bellcrank upper clevis and the ramp station 10L/R rod bellcrank upper clevis. (2) Adjust the gap between ramp station 10 L/R hook bellcrank and bellcrank stop, and check movement of the ramp station 10 L/R hook bellcranks. (3) Check the ramp station 10L/R hooks for the maximum extension requirements in

Step VI, and for the minimum spring force requirements in Step VII.

Adjust and install the right- and left-hand, forward connecting rod (see Figure 2) in accordance with the procedure defined in Step IX, except: (1) Install rods between the ramp station 4L/R rod bellcrank upper clevis and the ramp station 2L/R rod bellcrank lower clevis. (2) Adjust the gap between the ramp station 2L/R hook bellcrank and bellcrank stop, and check movement of the ramp station 2L/R hook bellcranks. (3) After adjusting for the proper gap as stated in item (2) of this paragraph, rotate the rod end 1/2 turn, shortening the rod assembly approximately 0.02" in lieu of lengthening as stated in Step IX. (4) Check the ramp station 2L/R hooks for the maximum extension requirements in

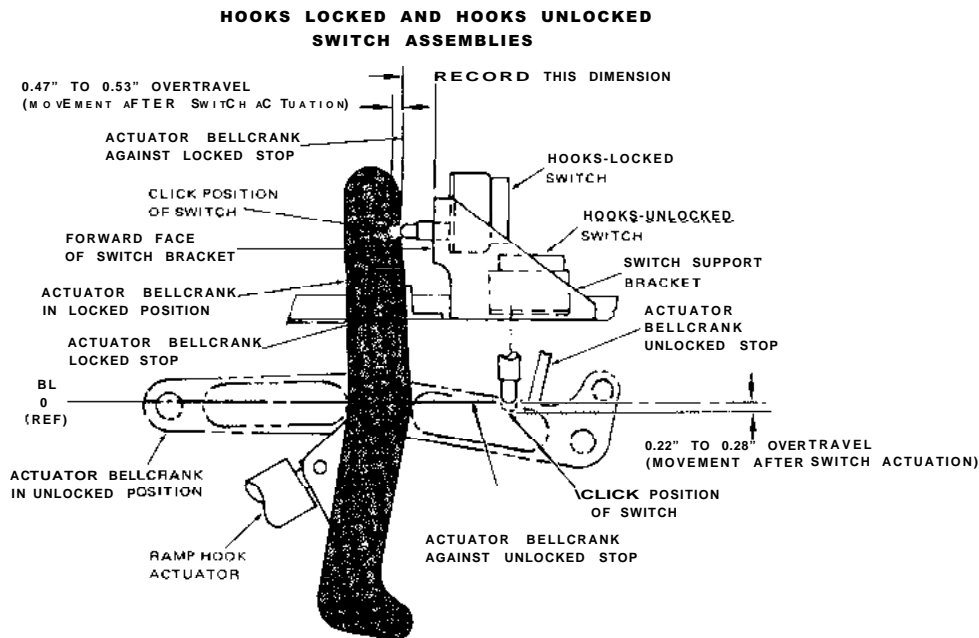
Step VI, and for the minimum spring force requirements in Step VI I.

Adjust the hooks-locked and hooks-unlocked switch assemblies to the overtravel requirements shown in Figure 14 as follows.

NOTE: Rigging of the hooks-locked and hooks-unlocked switch assemblies may be accomplished at the end of the rigging procedure if desired.

(1) Remove the switch support bracket. Remove the hooks-locked and the hooks-unlocked switch assemblies from the bracket and re-install the bracket. (2) With the actuator bellcrank in the locked position, measure (and record for use later in item (8) of this step) the distance from the forward face of the switch support bracket to the actuator bellcrank as shown in Figure 14. (This is best accomplished by placing a six inch steel scale through the hooks-locked switch hole in the switch bracket, until it contacts the actuator bellcrank. Then, read the measurement at the forward face of the switch bracket.) (3) Move the actuator bellcrank to the unlocked position (see Figure 14). (4) Install the inner locknut and inner jamnut on the hooks-unlocked switch. Adjust the jamnut so that (a) when the switch is inserted into the switch

Figure 14



support bracket as shown in Figure 14 and the jamnut is in full contact with the switch bracket, the switch will contact the actuator bellcrank and will actuate (click), but (b) when the jamnut is rotated 1/2 turn counter-clockwise (moving the nut closer to the plunger), the switch will NOT actuate. Rotate the jamnut 1/2 turn (returning the nut to the position where the switch actuated). This will establish the actuation (click) position of the switch indicated in Figure 14.

NOTE: A test light may be used to establish the actuated position of the switch in lieu of the audible click, provided the ship's wiring is not connected to the switch.

(5) After the actuation position is established by the foregoing procedure, move the jamnut an additional 0.25" away from the plunger (this can be accomplished by marking and then rotating the jamnut clockwise eight full turns). This will establish the 0.22" to 0.28" overtravel requirement indicated in Figure 14 for the hooks-unlocked switch. Tighten the inner locknut against the jamnut, being careful not to move the jamnut more than 1/4 turn. (6) Remove the switch support bracket. Insert the hooks-unlocked switch into its proper location in the switch support bracket; install the outer jam- and locknuts; and reinstall the switch support bracket. This completes the rigging of the hooks-unlocked switch.

(7) Establish and record the distance from the free position of the plunger to the actuated (click) position of the plunger on the hooks-locked switch as follows: (a) Measure and record the free length of the switch plunger (distance from the end of the plunger to the start of the threaded position of the switch). (b) Carefully depress the plunger until it just actuates (clicks) Measure and record the distance from the end of the plunger to the start of the threaded portion of the switch. (c) Subtract the dimension recorded in the foregoing item (b) from the dimension recorded in item (a). This is the switch pretravel from the free length to the actuated

(click) position. Record this dimension for use in the following item.

(8) Install inner jam- and locknuts on the hooks-locked switch. Adjust the jamnut so that when the switch is inserted into the switch bracket as shown in Figure 14 and the jamnut is in full contact with the switch bracket, the distance from the forward face of the switch bracket to the end of the plunger is the dimension recorded in item (2) of Step XIV, plus the dimension recorded in item (7)(c) of Step XIV plus 0.50". This will establish the 0.47" to 0.53" overtravel requirement indicated in Figure 14 for the hooks-locked switch. (9) Insert the hooks-locked switch into its proper location in the switch mounting bracket, and install the outer jam- and locknuts. This completes the rigging of the hooks-locked switch.

With the actuator bellcrank in the locked position, install the spring-loaded, ramp lock positioning rod, as shown in Figure 15. Install attachments through the rod ends, tighten

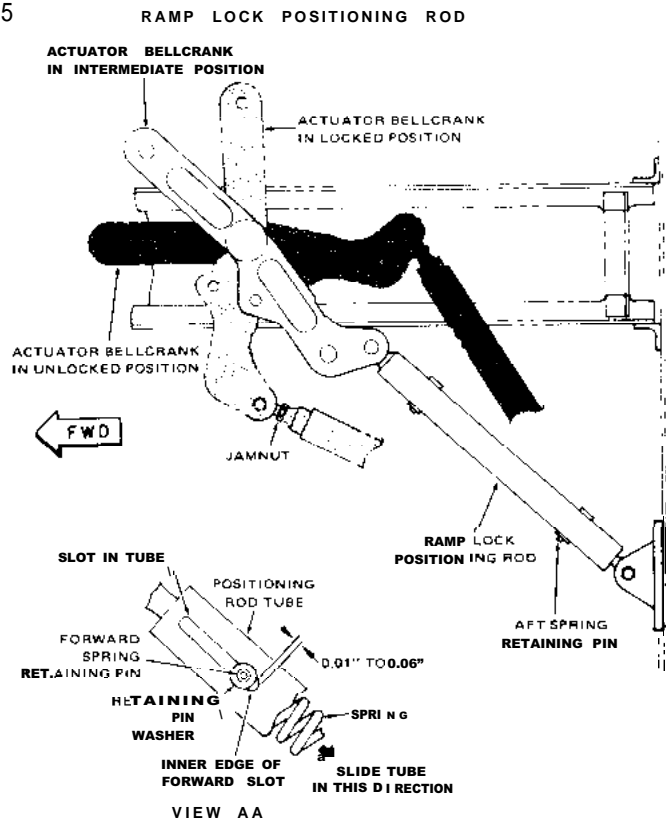
nuts just enough to eliminate end play in the bolt (do not overtighten).

Adjust the length of the positioning rod so that when the actuator bellcrank is in the intermediate position and is compressing the positioning rod the maximum amount, the forward spring retaining-pin washer clears the inner edge of the forward slot in the positioning rod tube by 0.01" to 0.06", as shown in view AA of Figure 15. When checking for the 0.01" to 0.06" dimension, slide the positioning rod tube in the direction indicated in view AA so that the aft spring retaining pin (see Figure 15) will contact the inboard edge of the aft rod-tube slot. After attaining the 0.01" to 0.06" dimension, tighten the jamnuts on the rod ends to a torque of 95 to 110 inch-pounds.

Reinstall the actuator to the actuator-support fitting (see Figure 3). Tighten the nut to only remove end play in the bolt (do not overtighten). Move the actuator bellcrank to the unlocked position (see Figure 3).

10

Figure 15



The internal rigging of the cargo ramp is now complete, and the treadway floor panel may be installed.

The hook actuator access panel is not installed at this time. Proceed with external ramp rigging.

Start external ramp rigging by adjusting the cargo ramp extension actuators in accordance with Step XVII I. Do not operate the ramp hooks at this time.

Remove all foreign objects (hoses, electrical cords, tools, nuts, bolts, etc.) from, and around, the cargo ramp.

Check the ramp hooks to see that they are in the unlocked position (up, and in the ramp structure as shown in Figure 13). If they are not, put them in the unlocked position.

Remove and replace the right- and left-hand fabric patches located on the ramp cylinder fittings (see Figure 16). Use Part No. 353613-31 or fabricate from No. 611 green, 8 ounce, cotton duck 0.020" thick and 4" x 5", specification CCC-P-77 I, type 4, or equal.

Raise the ramp and apply 2000 PSI to 3000 PSI pressure to the ramp cylinders in order to fully close the ramp.

Lower the ramp and inspect fabric patches on the ramp cylinder fittings (see Figure 16). An impression of the phenolic stop should be visible on each patch.

**NOTE:** An impression of the entire phenolic stop is not required.

If no impression is visible, adjust the ramp actuator rod end so that only two threads of the rod end are visible below the jamnut (see Figure 16).

The following procedure allows the rod end to be adjusted without

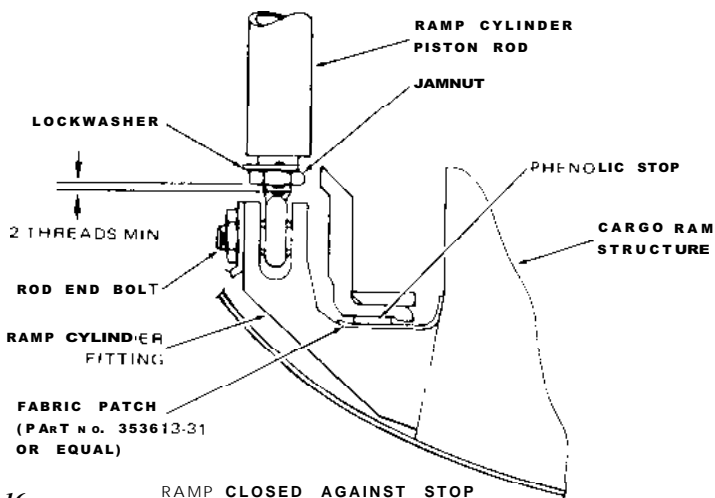


Figure 16

removing the rod end from the ramp fitting: (1) Remove the jamnut lockwire. (2) Lower the jamnut. (3) Disengage the lockwasher from the cylinder piston rod. (4) Rotate the ramp cylinder piston rod.

After the cylinder piston rod is lowered: (1) Reengage the lockwasher. (2) Tighten the jamnut to a torque of 200 to 250 inch-pounds. (3) Relock the jamnut.

Raise ramp and apply pressure to the cylinder as stated before. Lower the ramp and reinspect for impression of the phenolic stop. If an impression is

not visible, check parts for out-of-tolerance and replace discrepant parts. When impressions are visible on both fabric patches, proceed with rigging.

(1) Loosen the hook retainer attaching bolts at ramp stations 2, 4, 6, 8, and 10 (see Figure 17). (2) Remove the shims from behind and/or below the hook retainers. (3) Lower the hook retainers as shown in Figure 18.

Be sure the lower surface of the hook retainer is resting on the longeron

IMPRESSION ON FABRIC PATCH



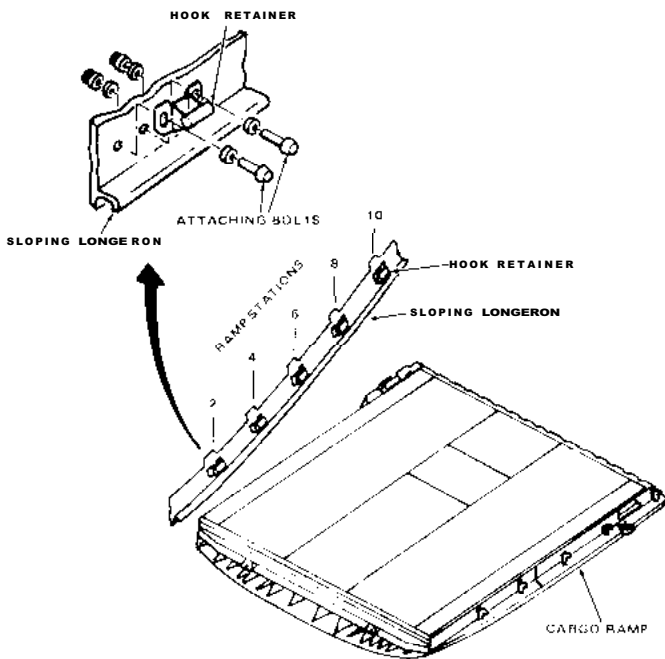


Figure 17

flange, or the upper surface of the hook retainer slots are resting on the attaching bolts (see Figure 18). Tighten the attaching bolts to a torque of 200 to 300 inch-pounds.

12

Measure and record the distance between the inboard surface of the right- and left-hand hook retainers (see Figure 19) at ramp stations 2, 4, 6, 8, and 10.

Note the ramp station with the smallest dimension recorded in Step XX. Loosen the hook retainer attachments at all ramp stations where the recorded dimension exceeds the foregoing smallest dimension by 0.060" or more.

Shim between the loosened hook retainers and the sloping longeron, as shown in Figure 20, using 0.32" thick (P/N 3303581-1 or equivalent) shims, so that the distance between the right- and left-hand hook retainers at ramp stations 2, 4, 6, 8, and 10 are equal (within  $\pm 0.06"$ ).

For each ramp station requiring shims, install an equal number of shims behind the right- and left-hand hook retainers.

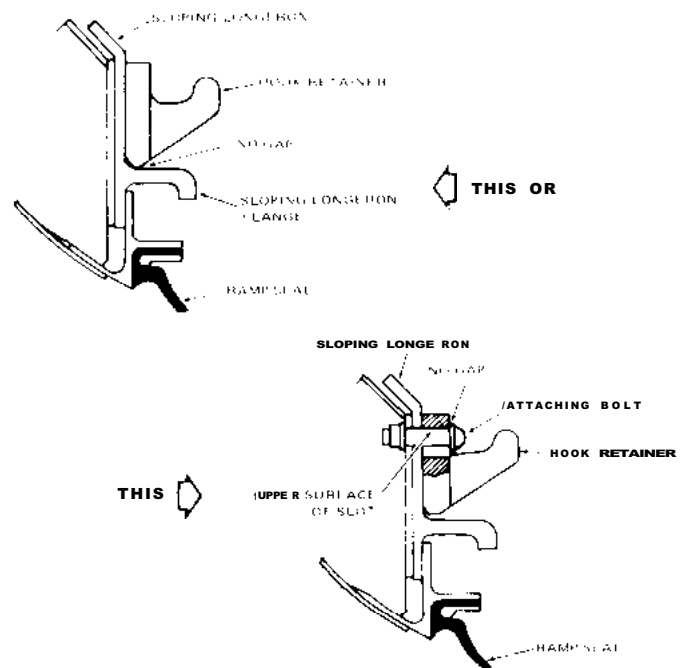


Figure 18

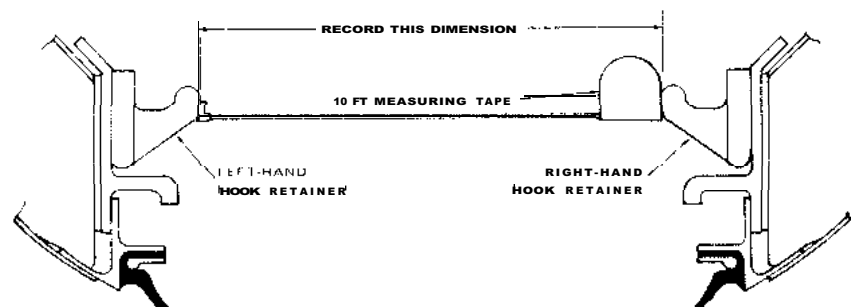


Figure 19

Be sure the lower surface of the hook retainer is resting on the longeron flange, or the upper surfaces of the hook retainer slots are resting on the attaching bolts (see Figure 18). Tighten the hook retainer attachments to a torque of 200 to 300 inch-pounds.

When the attaching bolts are tight, and the distances between the right- and left-hand hook retainers at all five ramp stations are equal (within  $\pm 0.06"$ ), proceed with rigging.

Remove all foreign objects (hoses, electrical cords, tools, nuts, bolts, etc.) from, and around, the cargo ramp.

Check the ramp hooks to see that they are in the unlocked position (up, and in the ramp structure as shown in

Figure 13). If they are not, put them in the unlocked position.

Raise and lock the ramp.

Using wire gages (0.03" diameter, 0.06" diameter, 0.09" diameter, 0.12" diameter, etc.). Measure and record the distance between the ramp hook and the hook retainer (see Figure 21) on the right- and left-hand side at ramp stations 2, 4, 6, 8, and 10.

Pull up on the hook using firm finger pressure when checking the above dimensions.

At ramp station 10 only, loosen the left- and right-hand hook retainer attaching bolts, being careful not to dislodge the shims behind the hook retainers: and add sufficient 0.032"

thick shims (P/N 3303581-3 or equivalent) under these hook retainers (see Figure 22) so that they will be raised the total dimension (within + 0.03" - 0.00") noted in Step XXI I for this ramp station.

Add one additional shim to raise the retainer an additional 0.032".

Using hand pump pressure, raise and lock the ramp. Record the maximum pressure required to fully actuate the ramp hook locking mechanism.

Ensure that mechanism is in the locked position (actuator bellcrank against the actuator beltcrank-locked stop). (See Figure 3).

Add or remove shims from under the hook retainers (equal number each side) as required to attain a locking pressure of 500 to 800 PSI when only the ramp station 10 hooks are in contact with their hook retainers.

With the ramp up and locked, check to see that both the right- and left-hand ramp station 10 hooks are in firm contact with their retainers, and cannot be moved forward and aft by using firm hand pressure. If either hook can be moved, remove all shims from under the hook retainers, retighten bolts and repeat Steps XXII and XXIII. When the ramp locking pressure is 500 to 800 PSI; when only the ramp station 10 hooks are in contact with their hook retainers; and when the ramp station 10 hooks cannot be moved forward and aft by using firm hand pressure, proceed with rigging.

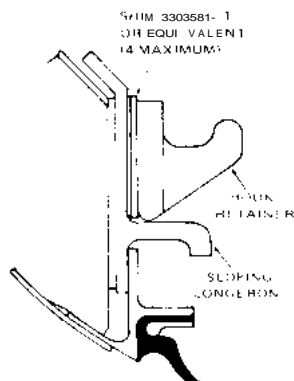


Figure 20

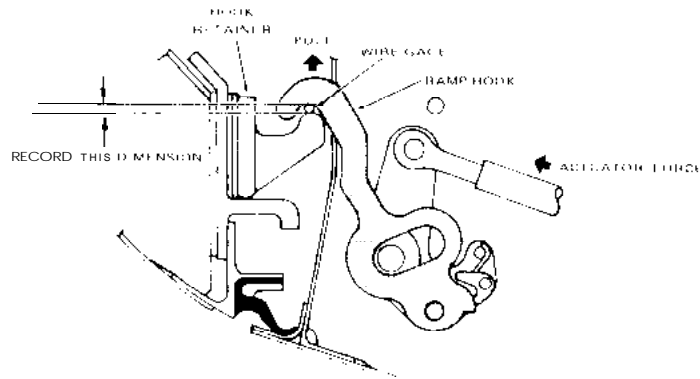


Figure 21

RAMP UP & LOCKED

Note dimensions recorded in Step XXI I for the ramp stations 2, 4, 6, and 8 left and right hook locations.

Being careful not to dislodge the shims behind the hook retainers, loosen the hook retainer attachments at all ramp stations where this dimension is 0.032" or more.

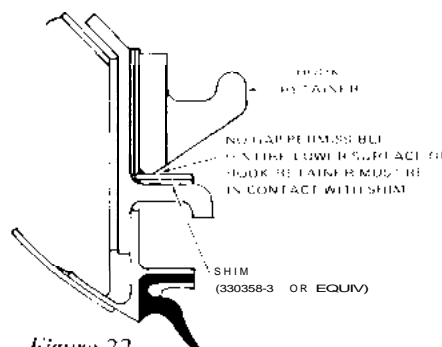
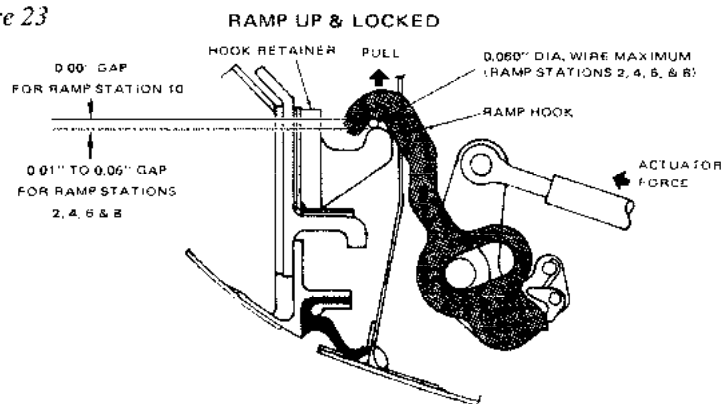


Figure 22

Add 0.032" thick (P/N 3303581-3 or equivalent) shims under the above loosened hook retainers, as shown in Figure 22, so that the retainers will be raised the total dimension (within + 0.00" - 0.03") noted in Step XXII.

When adding shims, do not exceed the dimensions noted in Step XXII for ramp station 2, 4, 6 and 8 hook locations.

Figure 23



No gap is permissible between the hook retainers and the shims. The entire lower surface of the retainer must be in contact with the shim.

Using hand-pump pressure, raise and lock the ramp. Record the maximum pressure required to fully actuate the ramp hook locking mechanism.

Ensure that the mechanism is in the locked position (actuator bellcrank against the actuator-bellcrank-locked stop). (See Figure 3).

Check each right- and left-hand hook at ramp stations 2, 4, 6 and 8 to see that they move forward and aft (a small amount being adequate to indicate the 0.01" minimum gap). Also check to see that they do not exceed the 0.060" maximum gap dimension between the ramp hook and the hook retainer (see Figure 23).

If, by using firm hand pressure, a 0.06" diameter (or larger) wire can be passed between the ramp hook and the hook retainer, add one additional 0.032" thick shim under that hook retainer (see Figure 22).

Tighten the hook retainer attaching bolts (see Figure 18) to a torque of

1,100 to 1,300 inch-pounds when:  
 (1) The hook retainers meet the 0.00" and 0.01" to 0.06" gap requirements shown in Figure 23. (2) The ramp locking pressure is 500 to 1200 PSI (check recorded pressure). (3) The retaining screws are installed in the lower shims. (4) The lower surfaces of the hook retainers are in full contact with the lower shims.

When the foregoing torquing requirements are met, proceed with rigging.

**STEP XXV**

Adjust the right and left ramp up switches to the overtravel requirements indicated in Figure 24 as follows: (1) Install the switch support bracket with the attachments located approximately midway in the slots of the support bracket, and tighten the nuts to a torque of 70 to 100 inch-pounds. (2) Close and lock the ramp. (3) Adjust the upper jamnut so that: (a) When the switch is inserted into the switch bracket and the upper jamnut is in full contact with the switch bracket upper surface, the switch will actuate (click).

**NOTE:** Firm finger pressure is required to actuate the switch.

(b) When the jamnut is rotated 1/2 turn (moving the jamnut closer to the plunger), the switch will not actuate. Rotate the jamnut 1/2 turn, returning the nut to the position where the switch actuated. This will establish the actuation position of the switch indicated in Figure 24.

**NOTE:** A test light may be used to establish the actuated position of the switch in lieu of the audible click, provided the ship's wiring is not connected to the switch.

(4) After the actuation position is established by the foregoing procedure. Mark and rotate the upper jamnut three full turns, moving the jamnut away from plunger. This will establish the 0.12" to 0.18" overtravel indicated in Figure 24. (5) Unlock and lower the ramp. (6) Install a lockwasher, lower the

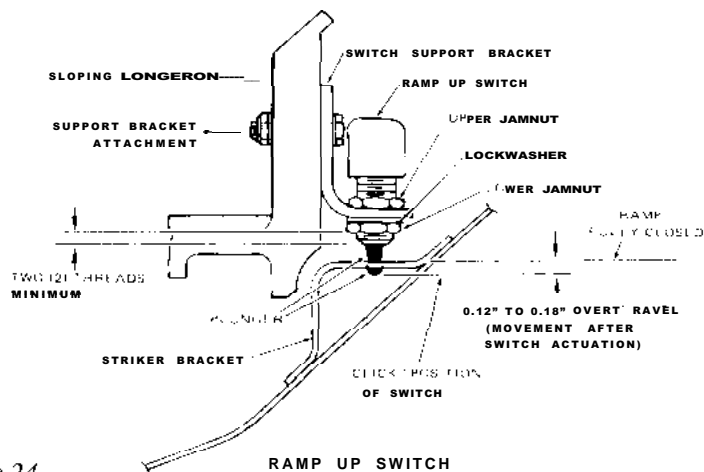


Figure 24

jamnut, and lockwire the upper and lower jamnuts.

If the actuation position indicated in item (3) cannot be attained because the upper jamnut is against the switch body, loosen the switch support bracket attachments and move the bracket down so that the attachments are at the top of the slots in the switch bracket. Retorque bolts and repeat item (3).

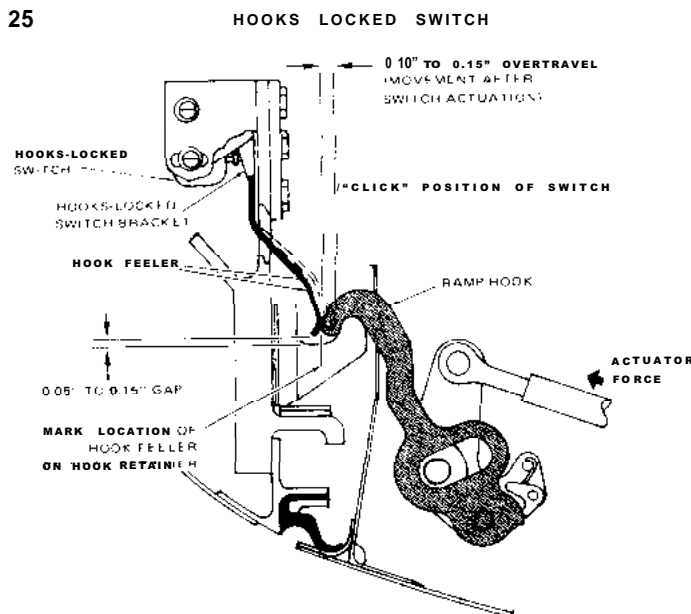
If the two thread minimum requirement indicated in Figure 24 cannot be attained, loosen the switch support bracket attachments and move the bracket up so that the attachments are at the bottom of the slots in the switch bracket. Retorque bolts, and repeat items (3), (4), (5), and (6).

**STEP XXVI**

Adjust the hooks-locked switches located at the ramp station IO hook retainers to the overtravel requirements shown in Figure 25 as follows: (1) With the ramp up and locked, adjust the right- and left-hand hooks-locked switch bracket inboard until the hook feeler contacts the ramp hook. Continue to move the switch bracket inboard slowly until the switch actuates (clicks). Mark the location of the end of the hook feeler on the hook retainer as shown in Figure 25. (2) Unlock and lower the ramp. (3) Move the switch brackets inboard so that the actuated (click) position of the switch is located 0.10" to 0.15" inboard of the position marked on the hook retainer noted in

14

Figure 25



item (1). This will establish the 0.10" to 0.15" overtravel requirement indicated in Figure 25.

It is permissible for the hook feeler to contact the lip of the hook retainer, but the hook feeler must be a minimum of 0.03" from the hook retainer lip when the switch deactuates (clicks on return).

#### STEP XXVII

Adjust the ramp down switch to the over-travel requirements indicated in Figure 26 as follows: (1) Unlock and lower the ramp until the lower ADS arm contacts the upper ADS arm stop. (See Figure 26.) (2) Adjust the lower jamnut of the switch so that: (a) When the switch is inserted into the switch bracket and the lower jamnut is in full contact with the switch bracket lower surface, the switch will actuate (click). But, (b) when the jamnut is rotated 1/2 turn (moving the jamnut closer to the plunger), the switch will not actuate. Rotate the jamnut 1/2 turn (returning the nut to the position where the switch actuated). This will establish the actuation position of the switch indicated in Figure 26.

NOTES: (A) A firm finger pressure is required to actuate the switch. (B) A test light may be used to establish the actuated position of the switch in lieu of the audible click, provided the ship's wiring is not connected to the switch.

(3) After the actuation position is established by the foregoing procedure, mark and rotate the lower jamnut three full turns, moving the jamnut away from plunger. This will establish the 0.12" to 0.18" over-travel indicated in Figure 26. (4) Install lockwasher and upper jamnut (5) Lockwire the upper and lower jamnuts.

This completes the ramp lock system rigging procedure. The following Step, XXVII, is a test procedure to verify the over-center condition of the ramp locks.

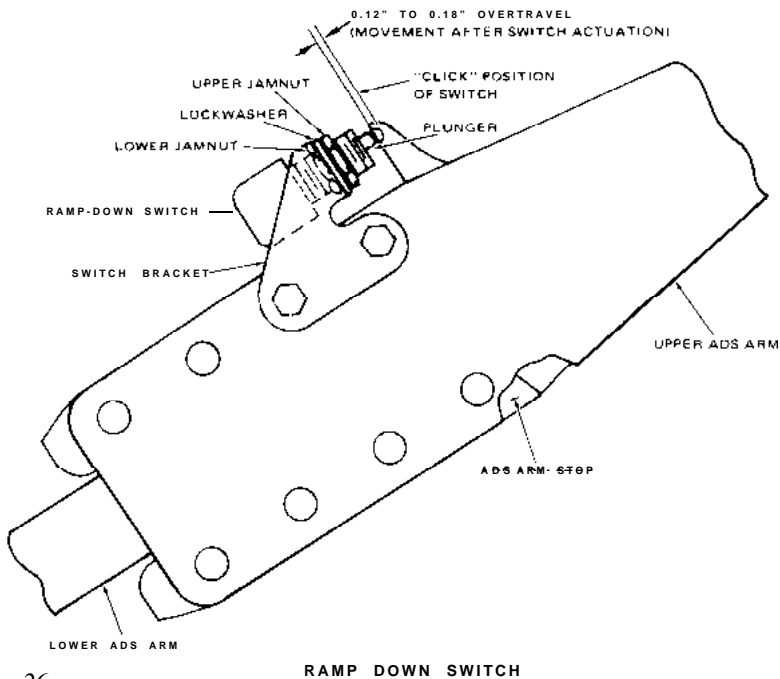


Figure 26

RAMP DOWN SWITCH

## RAMP HOOK TEST

#### STEP XXVIII

This test is designed to determine if each ramp hook is, or is not, in the fully locked (overcenter) position as shown in Figure 10; and it should be performed on those inservice aircraft that have experienced faulty latching of the cargo ramp hooks.

In order to remove only components which have readily accessible attachments, and to facilitate the use of hydraulic power to reposition the ramp hooks, this test calls for the repetitious removal and reinstallation of numerous ramp components. This procedure is progressive in nature and should be performed in the prescribed sequence. The ramp components should be removed in lieu of loosening only one end of an item; this is to eliminate any possibility of damage to the ramp structure or injury to test personnel.

**CAUTION:** Use only the hand pump to apply the various hydraulic pressures specified in this test. Do not exceed the specified pressures; otherwise, structural damage may occur.

Prior to performing this test, check for compliance with items (I) through (10) noted under system requirements at the start of this article.

#### 1. RAMP STATION 10 HOOK TEST

- a. Close and lock the ramp. (All hooks will lock.)
- b. identify the right- and left-hand, aft connecting rods (see Figure 2) by marking the aft portion of the rod "ramp station 10 right" and "ramp station 10 Left" as applicable, and remove the rods. Bag, identify, and retain all attachments.
- c. Unlock ramp. (The ramp station 10 hooks will remain locked.)
- d. Test as follows:  
Check to see that the inboard arms of the rod bellcranks, for the hooks being tested, are in the aft-most position. This will ensure that the hook bellcranks for the test hooks are positioned against the hook beltcrank stops. (See Figure 27.) Using the ship's hand pump, slowly apply 500 PSI maximum pressure to the ramp cylinders, attempting to open the ramp. The hooks should be in the "overcenter" position

and remain locked. If one of the hooks is not in an “over-center” position, the hydraulic pressure applied to the ramp cylinders will cause the hook bellcrank to rotate, thus unlocking the hook.

The ramp will then open slightly on the side of the unlocked hook. In this event, immediately reduce the hydraulic pressure to zero and contact appropriate engineering or technical personnel. An unlocked hook will be free to rotate to the full unlocked position using hand force only.

#### NOTE

If hooks remain locked, reduce hydraulic pressure in cylinders to zero and proceed with test.

- e. Lock the ramp and reinstall the aft connecting rods. Nuts may be installed only finger-tight at this time. (All hooks are locked.)

### 2. RAMP STATION 2 HOOK TEST

- a. Identify the right- and left-hand, forward connecting rods by marking the forward portion of the rod “ramp station 2 right” and “ramp station 2 left” as applicable, and remove the rods. Bag, identify, and retain all attachments.
- b. Unlock the ramp. (The ramp station 2 hooks will remain locked.)
- c. Test as follows:  
Same as 1.d. except, slowly apply 100 PSI maximum pressure in lieu of 500 PSI maximum.
- d. Remove the right- and left-hand, aft connecting rods. Bag, identify, and retain all attachments.

- e. Lock the ramp and reinstall the forward connecting rods only. Nuts may be installed finger-tight at this time. (The ramp station 10 hooks will remain unlocked.)

### 3. RAMP STATION 8 HOOK TEST

- a. Identify the right- and left-hand, center aft, connecting rods by marking the aft portion of the rod “ramp station 8 right” and “ramp station 8 left” as applicable, and remove the rods. Bag, identify, and retain all attachments.
- b. Unlock the ramp, (The ramp station 8 hooks will remain locked.)
- c. Test as follows:  
Same as 1.d. except, slowly apply, 400 PSI maximum pressure in lieu of 500 PSI maximum.
- d. Remove the right- and left-hand, forward connecting rods. Bag, identify, and retain all attachments.
- e. Lock the ramp and reinstall center aft connecting rods only. Nuts may be installed finger-tight at this time. (The ramp station 2 and ramp station 10 hooks will remain unlocked.)

### 4. RAMP STATION 4 HOOK TEST

- a. Identify the right- and left-hand, center forward, connecting rods by marking the forward portion of the rod “ramp station 4 right” and “ramp station 4 left” as applicable, and remove rods. Bag, identify, and retain all attachments.
- b. Unlock the ramp. (The ramp station 4 hooks will remain locked.)
- c. Test as follows:  
Same as 1.d. except, slowly apply, 200 PSI maximum pressure in lieu of 500 PSI maximum.

- d. Remove the right- and left-hand, center aft, connecting rods. Bag, identify, and retain all attachments.

- e. Lock the ramp and reinstall the right- and left-hand, center forward, connecting rods. Nuts may be installed finger-tight at this time. (The ramp station 2, ramp station 8, and ramp station 10 hooks will remain unlocked.)

### 5. RAMP STATION 6 HOOK TEST

- a. Unlock the ramp and remove the right- and left-hand, center forward, connecting rods. Bag, identify, and retain all attachments. (All hooks will be unlocked.)
- b. Lock the ramp. (The ramp stations 2, 4, 8 and 10 hooks will remain unlocked.)
- c. Remove the attachments common to the right- and left-hand ramp station 6, rod bellcranks and the control rods.
- d. Unlock the ramp. (The ramp station 6 hooks will remain locked.)
- e. Test as follows:  
Same as 1.d. except, slowly apply 300 PSI maximum pressure in lieu of 500 PSI maximum.

### 6. REINSTALLATION OF CONTROL AND CONNECTING RODS

- a. This completes the ramp hook test. The control rods and connecting rods should now be reinstalled.

Before starting the reinstallation, ensure correct placement of the removed items by checking the location markings put on the components during this test.



Reinstall the left-hand control rod assembly in the clevis of the ramp stations 6L rod bellcrank. Reinstall the right-hand control rod in the clevis of the ramp station 6R rod bellcrank. Tighten attachments through the rod ends. First, finger-tighten; then, tighten to the first castellation on the nut (do not overtighten), and install cotter pins.

b. Reinstall the left- and right-hand, center aft, connecting rods in the ramp stations 6L and 6R, rod bellcrank, lower clevis; and in the ramp stations 8L and 8R, rod bellcrank, lower clevis. Install attachments through the rod ends, tightening nuts only to eliminate end play in the bolt (do not over-tighten).

c. Reinstall the left- and right-hand, center forward, connecting rods in ramp stations 6L and 6R, rod bellcrank, upper clevis; and ramp station 4L and 4R, rod bellcrank, lower clevis. Install attachments through the rod ends, tightening nuts only to eliminate end play in the bolt (do not overtighten).

d. Reinstall the left- and right-hand, aft connecting rods in the ramp stations 8L and 8R, rod bellcrank, upper clevis and the ramp stations 10L and 10R, rod bellcrank, upper clevis. Install attachments through the rod ends, tightening nuts only to eliminate end play in the bolt (do not overtighten).

e. Reinstall the left- and right-hand, forward connecting rods in the ramp stations 4L and 4R, rod bellcrank, upper clevis; and the ramp stations 2L and 2R, rod bellcrank, lower clevis. Install attachments through the rod ends, tightening nuts only to eliminate end play in the bolt (do not overtighten).

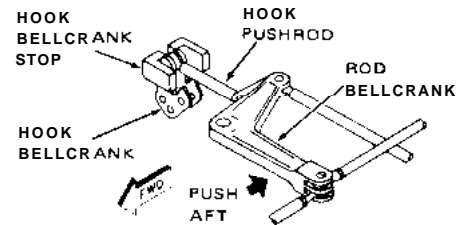


Figure 27

This completes the ramp hook test.

**SERVICE BOWS**

## StarTip

### DON'T Slam the Door . . . .

by D. A. Valley, *Service Representative*

Over the years, the Hercules aft cargo door has endured a lot of abuse during the closing operation. Sometimes, when CLOSE is selected, the door can be driven out of the uplock with a bang - which does neither the door lock nor structure any good. One way of preventing this is to select DOOR OPEN with the manual selector handle and apply hydraulic pressure with either the hand-pump or auxiliary pump until the

door physically moves off the latches. Then pull the emergency release handle, return the manual selector handle to NEUTRAL, and the door will free fall gently to the closed position. It takes a little longer, but wear and tear are minimized.

#### NOTE

Some later model Hercules have a snubber installed on the aft door designed to prevent the above condition. The snubber, along with required structural changes, can be retrofitted to all Hercules aircraft. *Service Bulletin 382-093* defines these changes for Commercial Hercules aircraft and *Service Bulletin 82-299* delineates these changes for Foreign Direct Hercules aircraft.



# Hercules Flap System

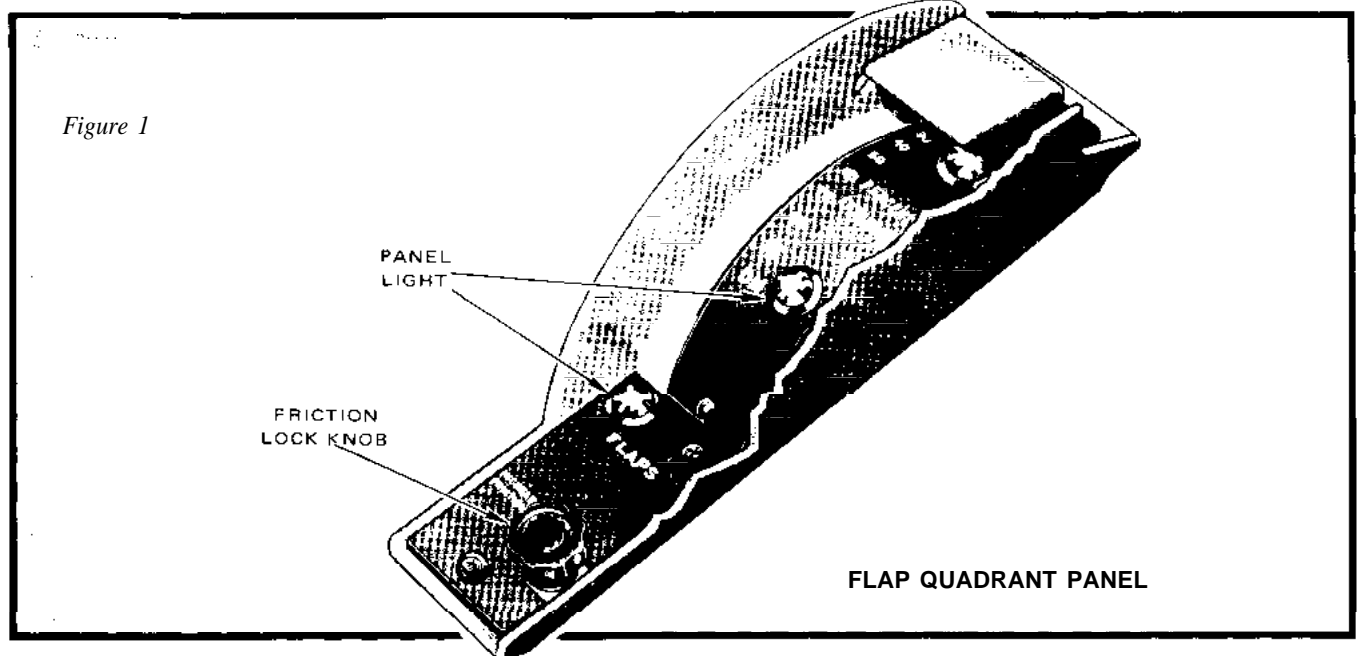


18

Our capacity for taking things for granted is sometimes amazing. We assume our car will start the next time we turn the key; that our TV will come on the next time we flip the switch; that our ball point pen will write every time. And that's as it should be. We should also have the right to assume all the systems in our airplane will function properly. For instance; as long as utility hydraulic pressure and DC electrical power are available, the flaps on the Hercules should operate - and usually do. But suppose we are lacking one or the other - or both - ingredients. What then? Sure, we all know how the flap system works, but let's refresh our memory.

The major components of the system are: The selector lever in the flight deck (Reference Figure 1.), the flap drive control and motor (Reference Figure 2.), the flap brake, the flap control (selector) valve, the emergency flap brake valve, and the asymmetrical sensing switches and brakes. (Reference Figure 3.)

The four (two per wing) Fowler-type wing flaps are manually controlled and hydraulically actuated. Movement of the control lever in the flight deck quadrant is transferred through the interconnecting cable system to the flap drive control unit. Switches in the flap drive



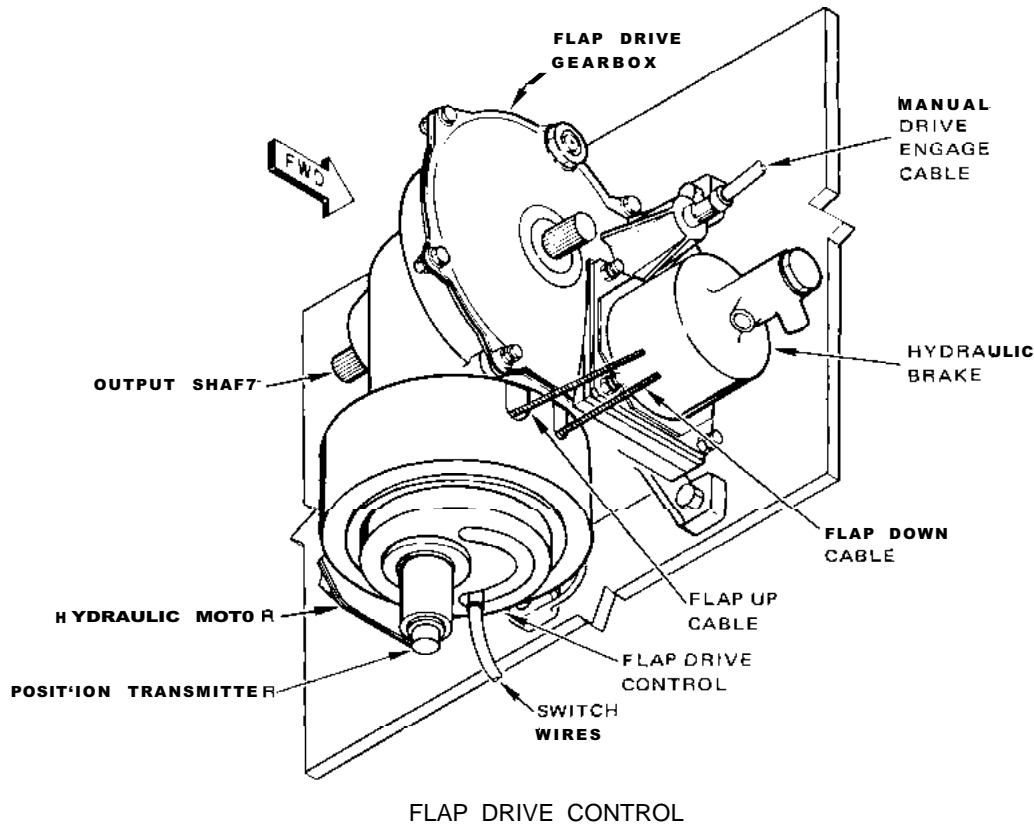
follow-up unit are actuated, completing the circuit to either the UP or DOWN solenoid of the flap selector valve, as selected. (Reference Figure 4 and 5.) Utility system hydraulic pressure is directed by the flap selector valve to drive the flaps in the desired direction. This fluid passes through the emergency flap brake valve to the flap selector valve.

The normal (deenergized) position of the emergency flap brake valve diverts utility system hydraulic pressure to the flap selector valve and connects the hydraulic line for the asymmetrical brakes to the utility system return line. More about these brakes later.

Flap operation is basically the same in either direction – the reversible hydraulic motor drives either up or down as selected. Flow regulators and restrictors maintain a uniform pressure drop through the motor, preventing overspeeding or cavitation due to air loads being imposed while the flaps are retracting.

During normal operation of the flaps, the asymmetrical brakes, located at the extreme outboard ends of the torque shafts, are spring-loaded OFF to the release position. The asymmetrical brakes are applied by hydraulic pressure. In the normal (deenergized) position, the emergency flap brake valve keeps the brakes' hydraulic line

Figure 2



The first action of the hydraulic pressure is to release the spring-actuated flap brake mounted on the flap drive gear box. With the brake released, the hydraulic motor is driven in the direction called for by the selector handle. When the flaps reach the selected position, follow-up switches in the flap drive unit are actuated, deenergizing the flap selector valve and removing pressure from the drive motor and brake. Flap movement stops and the spring-loaded brake engages to hold the flaps in position.

open to return. Mounted along with the brakes and driven by the torque shafts are the asymmetry sensing assemblies, consisting of three switches each. As long as the torque shafts are moving together (synchronized), the sensing switches can't complete the circuit to the emergency flap brake valve. If a torque shaft should break or otherwise get out of synchronization, further rotation will cause a pair of switches to close at the same instant, completing the circuit to the emergency flap brake valve.

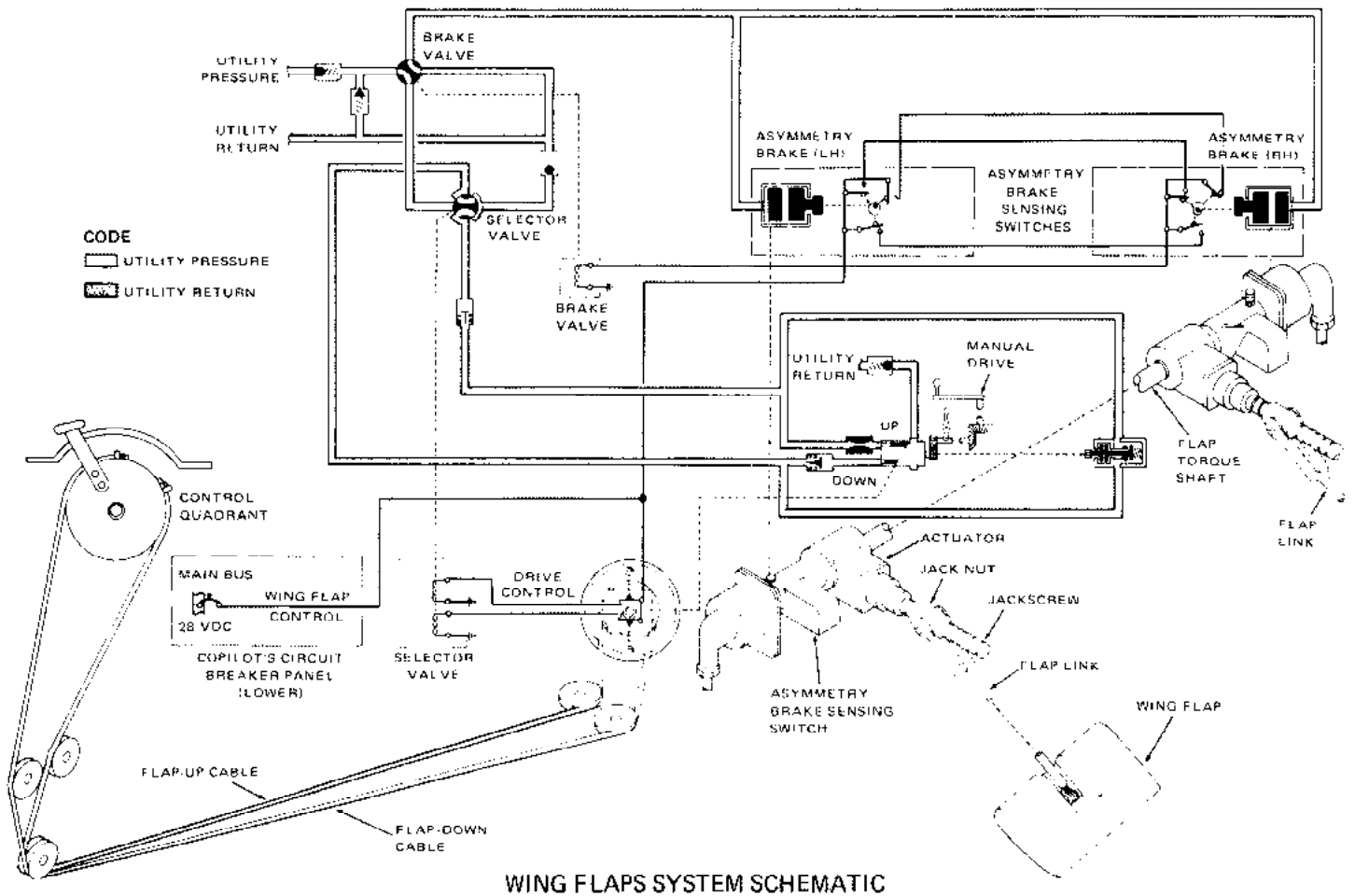


Figure 3

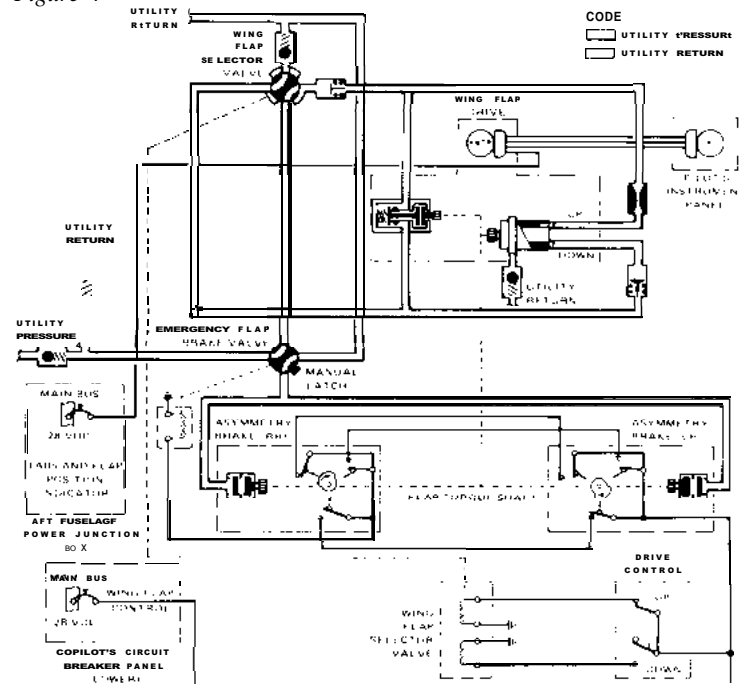
(Reference Figure 6.) When this valve is energized, pressure is diverted from the flap selector valve to the asymmetrical brakes, stopping flap movement and locking the flaps in position. The emergency flap brake valve has a manual latch for resetting the valve once the solenoid is deenergized.

**NOTE**

This should be accomplished only on the ground to prevent a worse "split-flap" condition.

As with any other system, our troubles can start with minor malfunctions that may be compounded by inadvertent, or hasty action. In other words, familiarity breeds contempt. Let's say we select flap down and nothing happens. The hydraulic system looks normal, so we assume that the problem must be electrical. Then we go to the flap selector valve located on the left side of the fuselage, forward of the left wheel well, and actuate the manual override button to the DOWN position. It is spring-loaded OFF and must be held in until the desired flap position is reached. The flaps start moving down, and suddenly the pilot calls "SPLIT FLAPS" as the airplane

Figure 4



WING FLAPS SYSTEM SCHEMATIC  
 UP OPERATION

rolls. Imagine performing this operation during a maneuver such as a turn onto final approach on a turbulent day. Things could get out of hand in a hurry.

But, you say, the asymmetry sensing switches would immediately sense the out-of-sync operation of the flaps and lock them in place. Look at the electrical schematic again. The asymmetry sensing switches are powered through the same circuit breaker as the control system. Trouble in the control circuit could very well render the asymmetry circuit inoperative. So, if you aren't sure where the trouble lies, actuate the manual override of the flap selector valve in small increments and verify synchronized flap movement before going past the point of no return.

#### NOTE

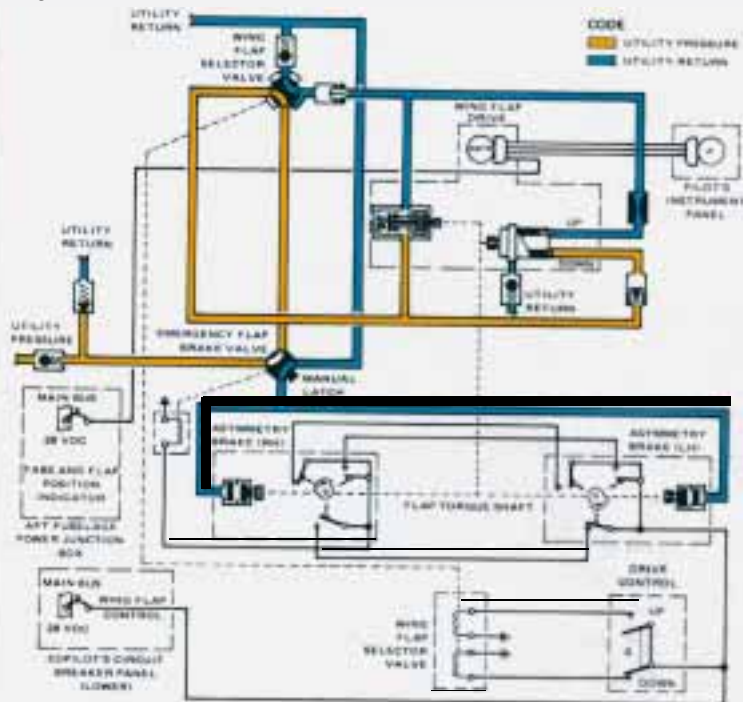
If the emergency flap brake valve has already been energized by the asymmetry sensing circuit, DO NOT reset until on the ground. The "split-flaps" condition could drive beyond the point of aircraft control.

When hydraulic pressure is not available, the flaps can be cranked down by hand (or up, for that matter). Just follow the placarded directions. Again, check for synchronized flap movement – remember, hydraulic pressure and electrical power are required to set the asymmetrical brakes.

The flap position indicator is powered through a separate circuit breaker; it will function even during manual operation. It indicates the position of the flap drive control assembly, but it will not indicate a "split-flaps" condition.

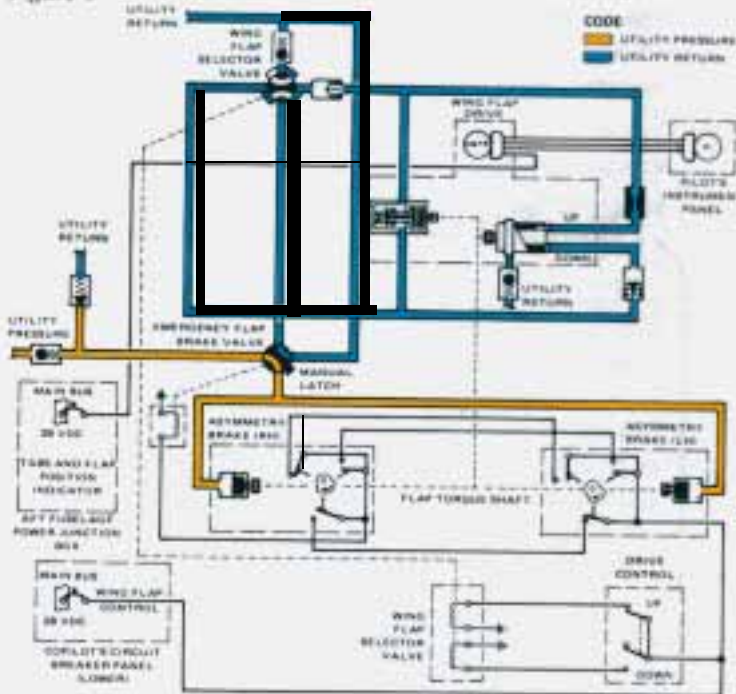


Figure 5



WING FLAPS SYSTEM SCHEMATIC  
DOWN OPERATION

Figure 6



WING FLAPS SYSTEM SCHEMATIC  
ASYMMETRY BRAKES ON

# An Upcoming Product Improvement – *new fuel quantity tank probes*

Lockheed Value Engineering recently produced an interesting cost benefit analysis which indicated that substantial cost savings and increased operational readiness would result from changing to an improved fuel quantity probe. Lockheed-Georgia is installing the improved probes on Hercules aircraft currently in production (ships 4736 and on). A retrofit kit is not currently available, however, one is under consideration.

Many of the problems with the old system originate in the electrical connections.

In the Hercules prior to ship 4736, the 186 electrical terminals on the 48 tank probes are NuLine miniature connectors. These connectors consist of several small parts which are difficult to handle in the close confines of fuel tanks. Also, soldering is required to attach the wires to the miniature connectors, which can be a problem because the present nickel-plated wires often yield cold solder joints. These miniature connectors are being replaced by threaded stud terminal strips on the new probes and crimp type terminals on the wires. The terminal studs are of mixed threaded sizes to prevent mismatching of connections.

22

There are 12 other miniature connectors in the fuel tanks; three at each tank bulkhead, plus one multipin Amphenol connector in each aux tank. Few problems have been reported with these connectors because they are not

exercised as much as the probe connectors. There is no plan to change these particular connectors on any retrofit program, but they will be replaced in the production aircraft (4736 and on), with the exception of the external tank interface which will remain unchanged. Also, the metal content of the system wiring is being changed to enhance the soldering characteristics and an improved wire insulation will be used to retard insulation breakdown.

The new probes are metal instead of fiberglass and are more tolerant of the effects of shock and vibration; and of contamination from water, fungi, and other foreign material. The testing and functioning of the new probes are identical to that of the existing probes.

The new probes represent a product improvement in new production aircraft. These new probes work with the older fuel indicators and with the new, more reliable indicators which are being introduced in production and offered as a preferred spare. Although the new probes are larger in diameter, the mechanical interface within the fuel system is not affected except that larger clamps are required and a new bracket is required for the compensator. All new clamps and brackets will pick up the existing fastener holes.

**SONIC NEWS**

## *StarTip*

### **Oil Pressure Transmitter Vent Line on JetStar Engines**

Several JetStar operators have reported that the engine oil pressure indication would decrease as aircraft altitude would increase. The amount of oil pressure indication decrease was a product of pressure altitude and rate of climb.

An investigation of the problem revealed that the interior of the oil pressure transmitter vent line (P/N 601883) had deteriorated. This caused the erroneous pressure indications.

The vent hose is metal braid covered, rubber lined, and 1/4 inch inside diameter. The hose

liner deteriorates from a combination of temperature and oil vapors. JetStar engineering has developed a replacement hose that should completely eliminate this problem. The new hose is flexible, all metal (stainless steel), and is identified as P/N 84074. In the event you are experiencing a decrease of oil pressure indication with an increase in altitude, and believe the subject hose to be the problem, we recommend replacement, preferably with the new hose.

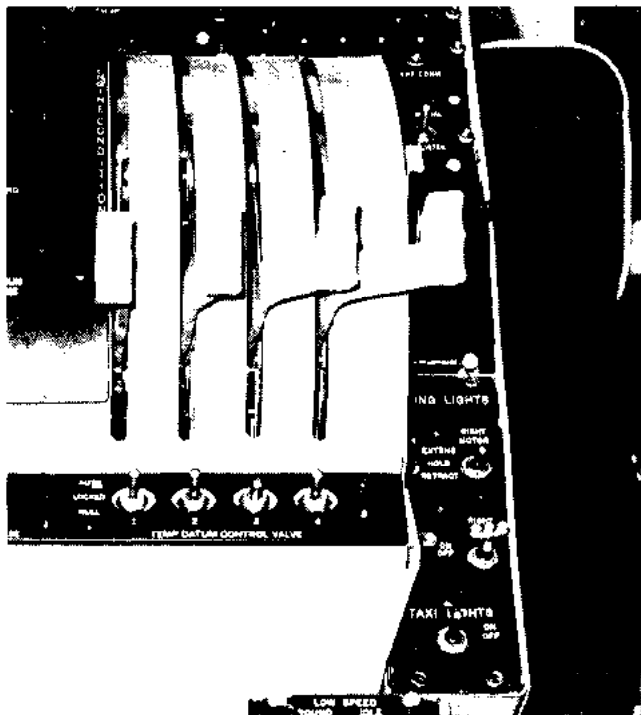
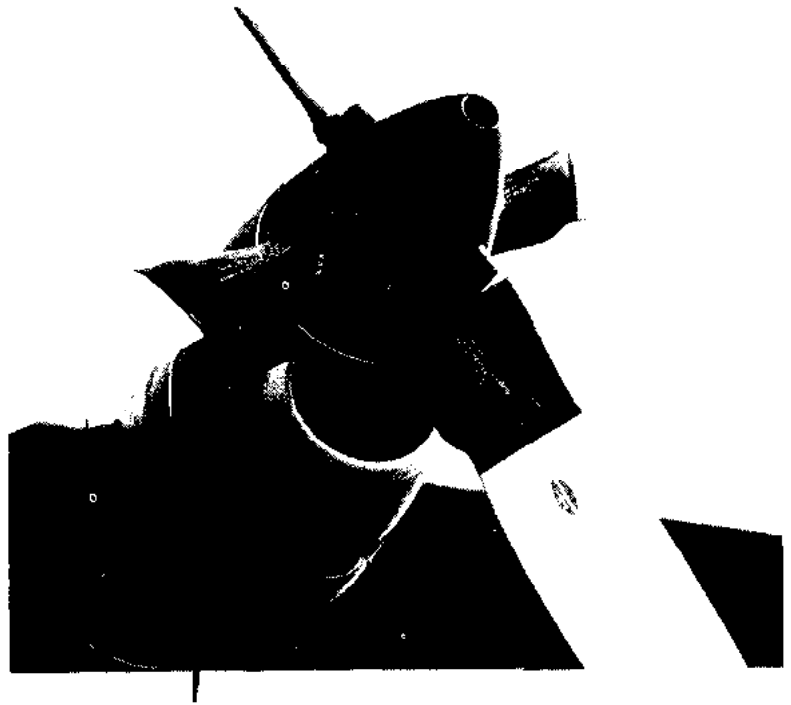
( Reference OM R A-71, dated 15 October 1976)

# Troubleshooting

## Engine Start Problems

by C. E. Shuler *Field Service Representative*

It used to be that if you had fuel fogging out the tail pipe and running out the drain mast during start (with no ignition), you had a defective ignition relay. If the fuel was fogging out the tail pipe, but not the drain mast, you had a defective ignition exciter. Now, with the capping of manifold drain lines or other means used to meet environmental requirements, we have had to change our thinking. The previous statements are still true, we just can't see what is taking place. The following procedures will isolate the problem when you have fuel flow but no ignition during start.



1. Place condition lever to GROUND STOP.
2. Remove speed sensing control electrical plug and jumper pins "A" to "E" in the cannon plug.
3. Place condition lever to RUN. If you now have ignition, the speed sensing control is defective. Replace it.
4. If you don't get ignition in step 3, place condition lever to GROUND STOP, leave pins "A" to "E" jumpered, and jumper terminals "15" to "20" inside engine junction box.
5. Place condition lever to RUN. If you now have ignition, the ignition relay is defective and should be replaced. If you don't have ignition, inspect the igniter plugs and harness. If they are good, the ignition exciter is the only remaining suspect. Test and replace if defective.

23

### NOTE

Consult the appropriate aircraft maintenance manual for procedure and safety precautions in testing ignition system components.

6. Restore engine to normal configuration.

CUSTOMER SERVICE DIVISION  
LOCKHEED-GEORGIA COMPANY  
A DIVISION OF LOCKHEED AIRCRAFT CORPORATION  
MARIETTA, GEORGIA 30063



## L-400



The L-400 is a proposed two-engine derivative of the classic C-130 Hercules, the world's most popular multipurpose transport. The L-400 will be a versatile cargo aircraft incorporating turboprop economy and Hercules reliability. Lockheed engineers have designed the L-400 to retain all the superior advantages of the C-130 and L-100 family of airplanes. It will have all the uncom-

promised cargo transport features of the standard Hercules and will be uniquely compatible with the existing Hercules fleet. The large cargo compartment and integral ramp with rear end, truck-bed level loading, together with Lockheed service and support will make the L-400 the logical choice to fulfill light transport requirements.