

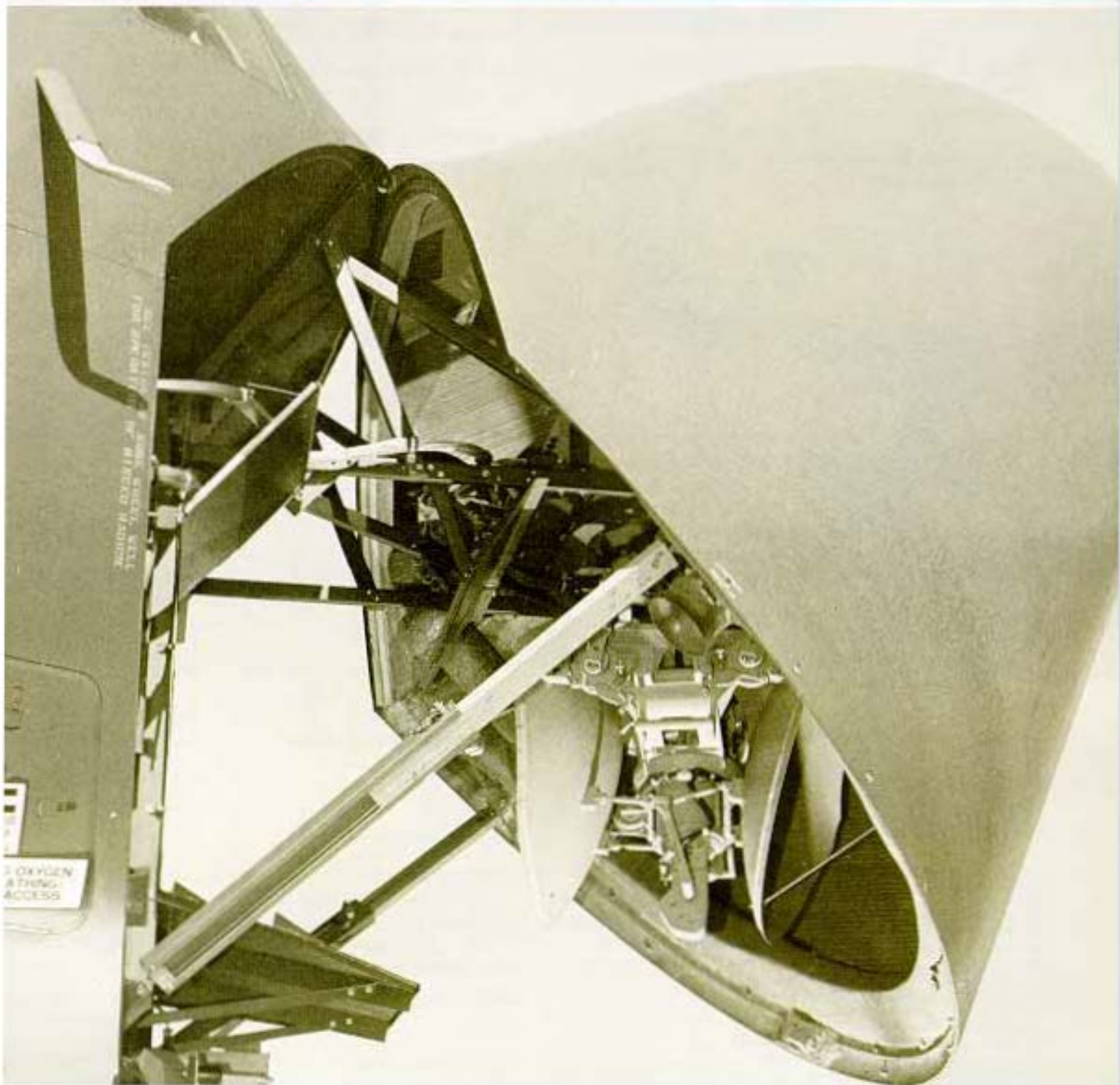

VOL. 4, NO. 4, OCTOBER - DECEMBER 1977

# *SERVICE NEWS*

A SERVICE PUBLICATION OF LOCKHEED-GEORGIA COMPANY, A DIVISION OF LOCKHEED AIRCRAFT CORPORATION



*APQ-122 Radar*



# **service news**

A SERVICE PUBLICATION OF  
LOCKHEED-GEORGIA COMPANY  
A DIVISION OF  
LOCKHEED AIRCRAFT CORPORATION

*Editor*

Jay V. Roy

*Associate Editors*

Charles I. Gale  
Don H. Hungate  
James A. Loftin

*Art Direction & Production*

Anne G. Anderson



Cover: The Hercules radome is open for access to the APQ-122 radar antenna. The antenna is positioned for fan beam operation and the pencil beam reflector is stowed aft.

Published by Lockheed-Georgia Company, a Division of Lockheed Aircraft Corporation. Information contained in this issue is considered by Lockheed-Georgia Company to be accurate and authoritative; it should not be assumed, however, that this material has received approval from any governmental agency or military service unless it is specifically noted. This publication is for planning and information purposes only, and it is not to be construed as authority for making changes on aircraft or equipment, or as superseding any established operational or maintenance procedures or policies. The following marks are registered and owned by Lockheed Aircraft Corporation: "Service News", "Lockheed", "Hercules", and "JetStar". Written permission must be obtained from Lockheed-Georgia Company before republishing any material in this periodical. Address all communications to Editor, Service News, Department 64-22, Zone 278, Lockheed-Georgia Company, Marietta, Georgia 30063. Copyright 1977 Lockheed Aircraft Corporation.

Vol. 4, No. 4, October - December 1977

## **CONTENTS**

- 3 **APO-1 22 Radar**
- 6 System Operation
- 7 Subsystems
- 14 Glossary
- 15 **Upper Cowling Hinge Lubrication**
- 16 **AC Voltage Regulators**
- 17 **Hercules MLG Ballscrew Lube**  
Side Lubrication Fitting Modified
- 18 **Spare Nuts For V-Band Couplings**
- 19 **KC-130R Flight Simulator**
- StarTip**
- 18 Boost Pump Electrical Connector

DIRECTOR T.J. CLELAND

MANAGER D.L. BRAUND

FIELD SERVICE & INVENTORY MGMT A.H. McCRUM

CUSTOMER TRAINING E. L. PARKER

JETSTAR SUPPORT H.L. BURNETTE

SPARES STORES & SHIPPING J.K. PIERCE

MANAGER M.M. HODNETT

SUPPLY PROCUREMENT R.C. WEIHE

SUPPLY SYSTEMS & INVENTORY CONTROL C.K. ALLEN

SUPPLY SALES & CONTRACTS H.T. NISSLEY, JR.

SUPPLY TECHNICAL SUPPORT J.L. THURMOND

# APQ-122 radar

by Ralph A. Romanis, *Electronics Engineer, Senior*

Radar is an electronic accessory to man's sensory equipment which makes it possible to detect certain objects at distances beyond the normal range of vision. The detection process is unimpaired by darkness, fog, smoke, or most clouds, and permits the distance (range) to the object to be determined, as well as the location (bearing) of the object with respect to the radar platform.

The word RADAR is an acronym coined from the descriptive phrase "radio detecting and ranging." Radar works by transmitting a pulse of energy and measuring the amount of energy reflected from the target and the time required for an echo of the pulse to return. The transmitted pulses are very brief in duration, and are spaced in such a manner that a time (receive) period follows each transmitted pulse. The timing of the pulses depends on the range that has been selected. During the receive period, echoes from close-in targets will be received first, then those from medium range targets, and finally echoes will be returned from targets at the maximum effective range of the system. When sufficient time has elapsed to allow echoes to be received from the most distant target of interest, the transmitter is pulsed again and the cycle is repeated. It is the linear relationship between range and time which is the basis of the ranging capability of radar.

The radio waves used in radar are propagated at the speed of light, and the time interval required to complete a cycle is very short; measurable in terms of microseconds for most terrestrial targets. Such brief intervals cannot be differentiated or even detected by a human observer, but electronically it is possible to distinguish between them with a high degree of precision.

Also, knowing accurately the direction in which the antenna is pointing at the instant an echo is received permits information about the bearing (azimuth) of an object to be determined. Once both the range and the bearing of an object are known, it is possible to show the position of the target and the radar platform relative to each other on a map-like display of the area covered by the radar signals.

The present generation of aircraft radar systems is the product of a long line of intensive developmental efforts in airborne radar which extends back to the days when the first bulky, unpredictable sets were crammed aboard



nightfighters and anti-submarine patrol craft in the early 1940s. Although many of the basic principles of radar have remained the same, the advanced solid-state units in use today bear little functional resemblance to those of three decades ago. Major technological breakthroughs, plus constant evolutionary improvement, have converted a cranky, cumbersome "secret weapon" into a reliable and indispensable aid for navigation and operational safety in all sectors of the aviation field.

3

The APQ-122(V)5 radar set has been installed on many Hercules aircraft since 1975, beginning with aircraft serial number LAC 4653. This radar system is representative of the advanced, multi-purpose airborne navigational radars currently available. It is a pulse-modulated, solid-state, frequency-agile, X-band system which provides precise navigational capabilities for long-range ground mapping, weather detection, and beacon interrogation.

The major components of the system are the antenna, antenna control, electronic control amplifier, receiver-transmitter, radar set control, cursor control, sweep generator, and the radar stabilization control. In addition, both pilot and navigator are provided with azimuth-range indicator (display) units. The pilot's indicator is a 5-inch direct view storage tube display suitable for the high ambient light conditions often present at this station. The navigator is provided with a 7-inch high-resolution cathode ray tube (CRT). In addition, the navigator can place electronic cursors over a specific target on the display and read out the range and azimuth of the target.

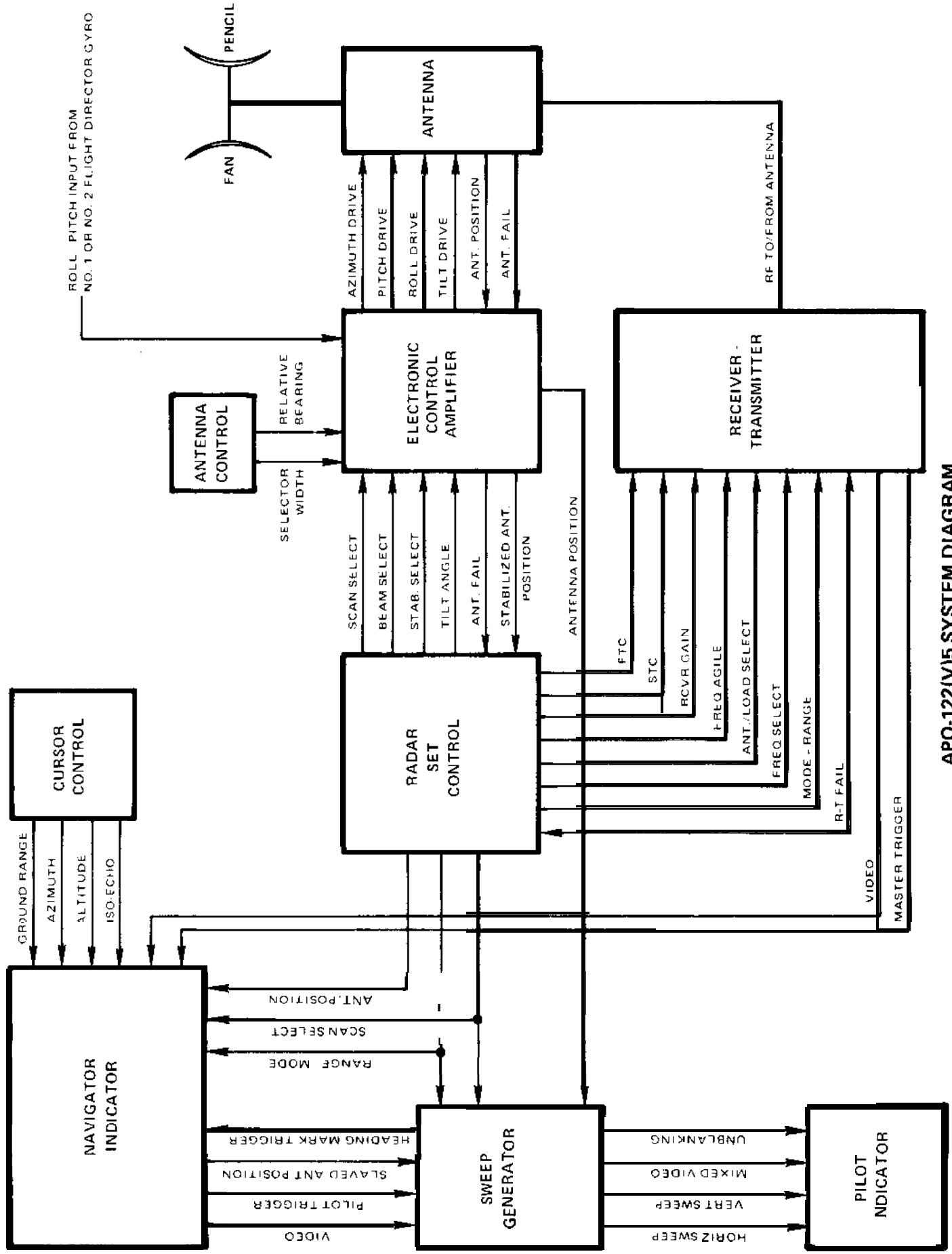

AP0-122(V)5 SYSTEM DIAGRAM





NAVIGATOR'S INDICATOR



PILOT'S INDICATOR



RADAR SET CONTROL PANEL

SWEEP GENERATOR\*

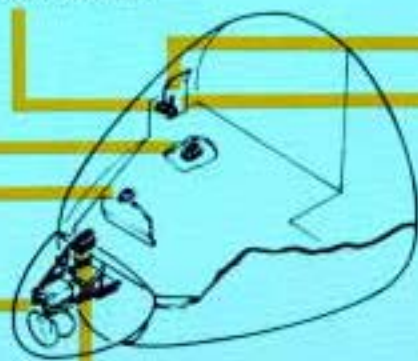

ELECTRONIC CONTROL AMPLIFIER



ANTENNA INSTALLATION\*

RECEIVER-TRANSMITTER\*



CURSOR CONTROL PANEL



ANTENNA CONTROL PANEL



RADAR STABILIZATION CONTROL PANEL

COMPONENTS AND LOCATION

\* From courtesy of Texas Instruments

## SYSTEM OPERATION

There are three modes of operation available on the APQ-122(V)5 radar set; map mode, beacon mode, and weather mode.

### Map Mode

The map mode is used to provide ground-mapping capability for navigation. When used in the long-range mapping mode, the radar set detects and displays targets such as shore lines and mountains at ranges in excess of 200 nautical miles. The following selectable range positions are available :

- 3-30/1- Placing the selector knob in this position selects variable display range from 0-3 to 0-30 nautical miles with range marks at 1 nautical-mile increments.
- 3-30/5- This position selects variable display range from 0-3 to 0-30 nautical miles with range marks at 5 nautical-mile increments.
- 50/10- At this position, a 0-50 nautical-mile display range is selected with range marks at 10 nautical-mile increments.
- 100/20- This position presents a 0-100 nautical-mile display range, with range marks at 20 nautical-mile increments.
- 240/30- When the range is set at this position, the maximum range of the radar set (approximately 240 nautical miles) is selected. Range markers are provided at 30 nautical-mile increments.

Range delay is available when the range switch is set at the 50/10, 100/20, or 240/30 positions. When this function is selected, the sweep is delayed so that an adjustable

segment (0-3 to 0-30 miles) of the displayed range is presented, generated about the range cursor. The range cursor may be positioned at any point from 0 to 240 nautical miles, depending upon the range switch position. The effect of range delay is to expand the display at long range, thereby highlighting a target.



CURSOR CONTROL PANEL

### Beacon Mode

The beacon function is available in all ranges. When the beacon mode is selected, the radar set's magnetron is driven to a fixed frequency (9375 MHz) and the frequency select and the frequency agility switches are rendered inoperative.

The beacon mode provides the tactical capability of interrogating an X-band beacon. The beacon reply is coded to enable an identification to be made, and can originate from either a ground station or an airborne station. Since the beacon reply is a transmitted signal, it can be detected at longer range than the echo of a radar pulse from conventional targets, although it still must be within the line of sight of the radar transmitter. This mode is often used to find aircraft of interest such as tankers for aerial refueling.

### Weather Mode

The weather function is also available in all ranges. In this mode of operation, the radar set detects and displays storm fronts, heavy rainfall areas, or other turbulent weather cells containing precipitation at distances of up to 150 nautical miles.

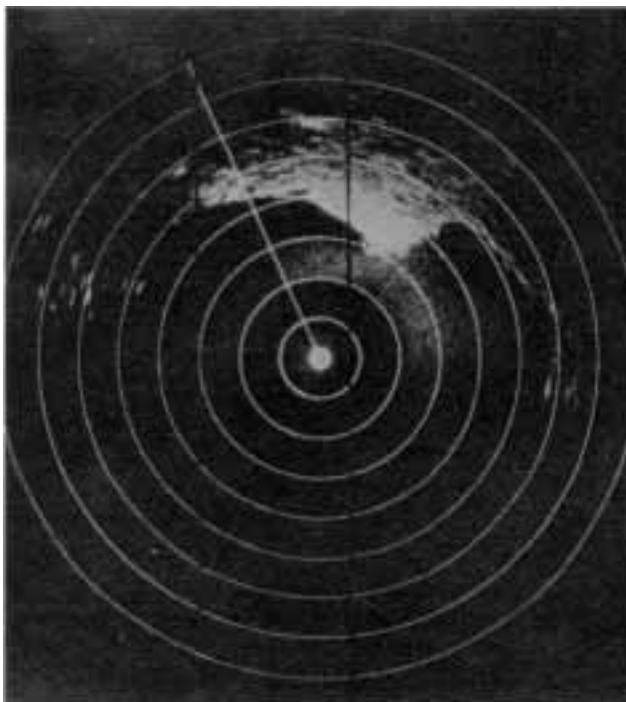

Photograph of APQ-122(V)5 radar display of Florida Gulf coast area - 240 NM range with 30-mile range marks. Radar in "north" stabilization with aircraft flying 330° true heading. (Returns are shown from St. Petersburg on the far right, to New Orleans, on the far left.) Photo courtesy of Texas Instruments.

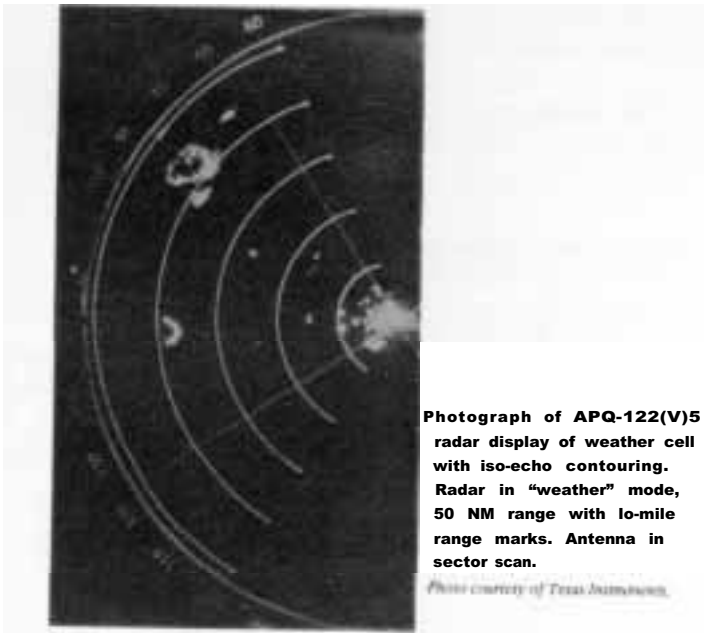

**Photograph of APQ-122(V)5 radar display of weather cell with iso-echo contouring. Radar in "weather" mode, 50 NM range with 10-mile range marks. Antenna in sector scan.**

*Photo courtesy of Texas Instruments.*

Selection of the weather mode activates the ISO-ECHO controls on the pilot's indicator and the cursor control panel, enabling the operator to vary the threshold at which storm contouring is displayed. The control permits the selective rejection of echos from light, medium, heavy, or excessively heavy precipitation. This allows an evaluation of the severity of storm cells to be made.

### SUBSYSTEMS

The APQ-122(V)5 radar set is divided into three major subsystems: the antenna, the receiver-transmitter, and the indicators. A closer look at each of these subsystems will help clarify their functions.

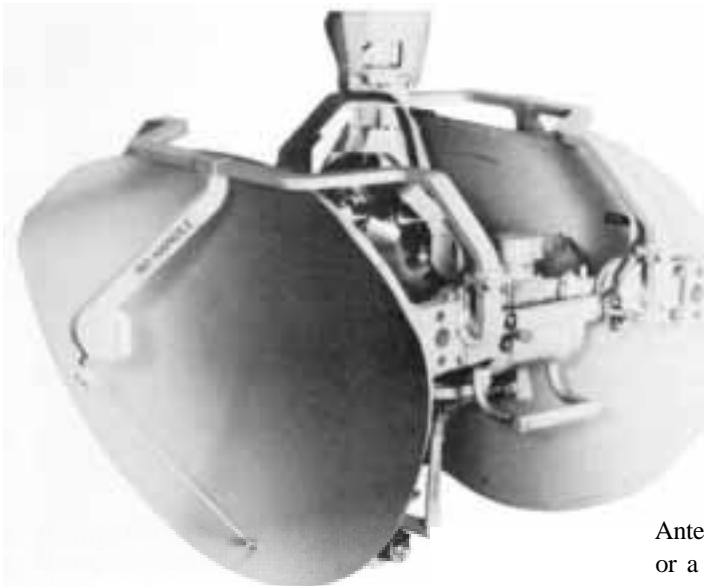

**Antenna reflectors are reversible for either a pencil or a fan beam.** *Photo courtesy of Texas Instruments.*

### Antenna Subsystem

The antenna subsystem focuses and directs radio frequency (RF) energy to and from the receiver-transmitter, and provides the interface between the aircraft and the ground over which the aircraft is flying. In addition, it generates positional information to accurately tie the bearing of targets in the azimuth plane to that of the aircraft for display on the navigator's and pilot's indicators. In the weather mode, antenna tilt angles are also used. This permits the height of weather cells to be determined so that not only the bearing of the cell is known, but also its altitude relative to the altitude of the aircraft. The antenna is stabilized with pitch and roll data supplied from the number 1 or number 2 flight director gyros.

The functions of the antenna subsystem are carried out by the antenna and the electronic control amplifier (ECA) and are controlled by the antenna control, radar set control, and radar stabilization control.

The antenna has two reflectors: One reflector radiates a pencil beam for long-range search and navigation, and weather detection. The other reflector radiates a fan beam which is used for ground mapping. The fan and pencil reflectors are mounted back-to-back on the antenna pedestal; they are positioned in azimuth and stabilized in pitch, roll, and tilt by a four-gimbal servosystem. Each reflector is selectable by a signal which comes from a switch marked BEAM-PENCIL/FAN on the radar set control. Because of the back-to-back configuration of the antenna reflectors, it is necessary to reverse the direction of the rotation of the tilt drive when changing reflectors. To initiate this change, a relay is energized which reverses the inputs to the tilt control circuit. This causes the tilt gimbal to reverse its direction of rotation.



**ANTENNA CONTROL PANEL**

## PENCIL BEAM

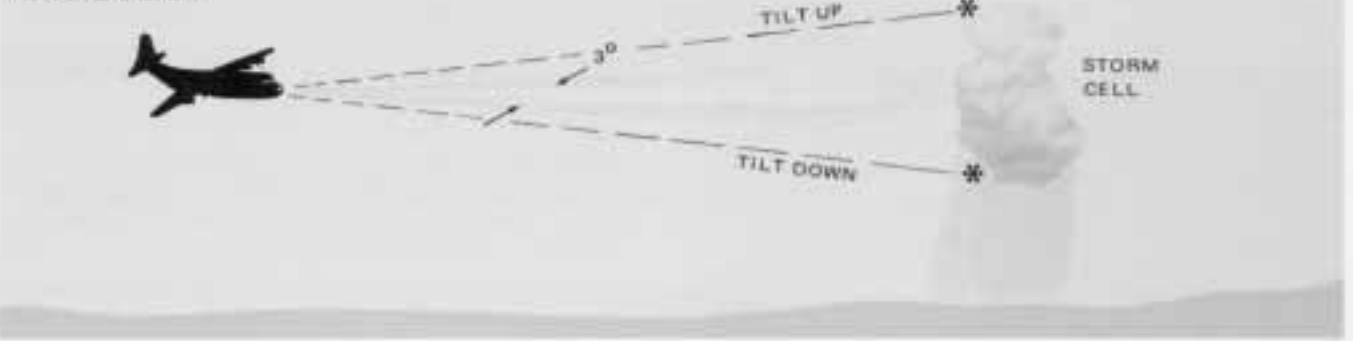

## FAN BEAM

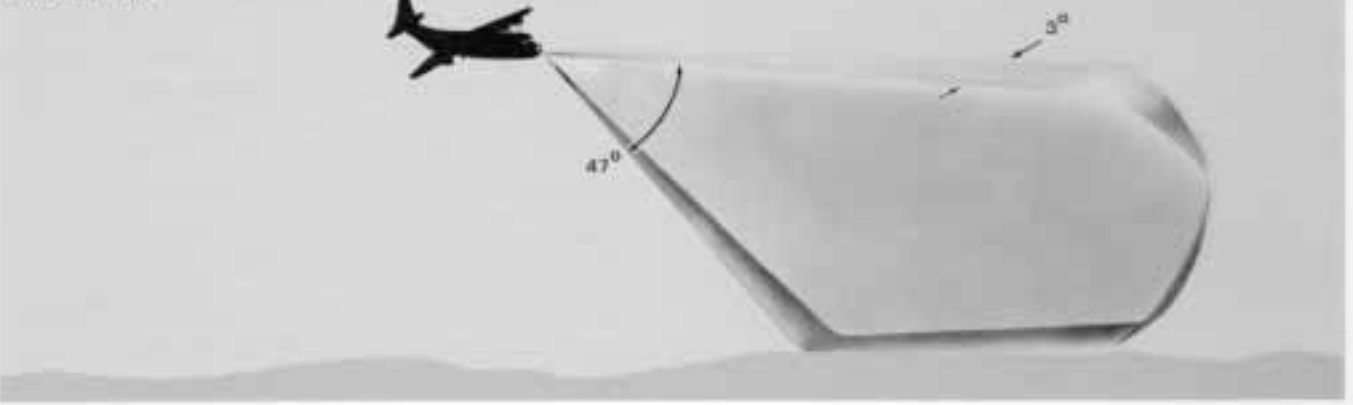

8

Input information is received by the ECA from the aircraft compass system, number 1 or number 2 flight director gyro, the radar set control, and the antenna control. These inputs generate signals which control the positioning of the antenna. The selection of gyro number 1 or gyro number 2 is made through a switch mounted on the radar stabilization control panel. Should both gyros fail, there is an off position (STAB OUT) which selects a zero reference for the radar antenna and “locks” it to the airframe. This position can also be used to check the antenna zero alignment during installation and ground checkout, and during troubleshooting.



RADAR STABILIZATION CONTROL PANEL

The ECA passes antenna positional information to the navigator's CRT indicator and processes the feedback information from the four antenna drives (roll, pitch, tilt, and azimuth) in such a way that the four loops are driven in a controlled manner. Loss of control, or a hard failure in any of the four loops, will result in an antenna or ECA fail indication on the ECA unit mounted in the radome. At the same time, the ANT FAIL light will be illuminated on the radar set control in the flight station.

## Receiver-Transmitter Subsystem

The receiver-transmitter (R-T) subsystem transmits and receives X-band RF energy and develops the video and master trigger pulses used by the pilot's and navigator's indicators. The R-T subsystem consists of the radar set control and the R-T. The following controls, located on the radar set control, are the principal ones used to operate the R-T:

FTC - Controls fast time constant, on-off.

STC - Adjusts sensitivity time control in depth and range.

RCVR GAIN - Controls receiver gain.

AGILE - Selects fixed (off) or varying (on) frequency on a pulse-to-pulse basis.

RF PWR - Directs RF power to antenna or dummy load.

MODE - Selects mode: off, standby, map, beacon, or weather.

RANGE - Selects each of the five display ranges.

FREQ - Permits selection of nine discrete operating frequencies.

**Transmit Mode** - The transmit mode is initiated by moving the mode switch from OFF to STBY (standby). Note that a mechanical interlock in the bottom of the switch knob must be released before the switch can be returned



to the OFF position. This prevents the operator from inadvertently deenergizing the set. The STBY position is a warm-up and test position in which 115 VAC, 3-phase power is supplied to the system ~ in particular to the synchronizer - to generate the radar timing pulses: modulator trigger, pre-master trigger, master trigger, and system blanking. (System blanking is not used in the system as configured.) The timing pulses occur at a pulse repetition frequency (PRF) of 250, 1,000, and 2,000 Hz, determined by the positions of the mode and range switches on the radar set control. At the completion of a 3-minute time delay, power is applied to the modulator, allowing the modulator to fire the magnetron. The modulator produces high voltage pulses which fire the magnetron at a PRF and pulse width (PW) determined by mode and range selections as follows:

Mode	Range (NM)	PRF	Pulse Width
MAP	3-30/1	2 KHz	0.3 $\mu$ s
MAP	3-30/5	2 KHz	0.3 $\mu$ s
MAP	50/10	1 KHz	0.6 $\mu$ s
MAP	100/20	250 Hz	4.0 $\mu$ s
MAP	240/30	250 Hz	4.0 $\mu$ s
BCN	All Ranges	250 Hz	2.35 $\mu$ s
WEA	All Ranges	250 Hz	4.0 $\mu$ s

The magnetron produces high power (60 KW minimum) transmitted pulses at a frequency determined by the selection made on the radar set control. The control has nine selectable frequencies in 50 MHz steps and is inhibited

during the BCN mode. The nine frequency steps are as follows:

Frequency Control Position	Generated Frequency (MHz)
1	9100
2	9150
3	9200
4	9250
5	9300
6	9350
7	9400
8	9450
9	9500

Frequency agile operation causes the frequency to be varied below the selected frequency to reduce scintillation in the returned echo display. It is initiated when the AGILE switch is placed in the ON position. Frequency agility is inhibited in the beacon mode.

The transmitter pulses are applied from the magnetron through a circulator and a waveguide switch to the antenna. Should it be necessary to check power output or to have the radar in the transmit mode, but not desirable to have RF energy being radiated by the antenna, there is a built-in dummy load. By switching from ANT to LOAD on the radar set control, RF energy is switched to the dummy load and a warning light is illuminated on the

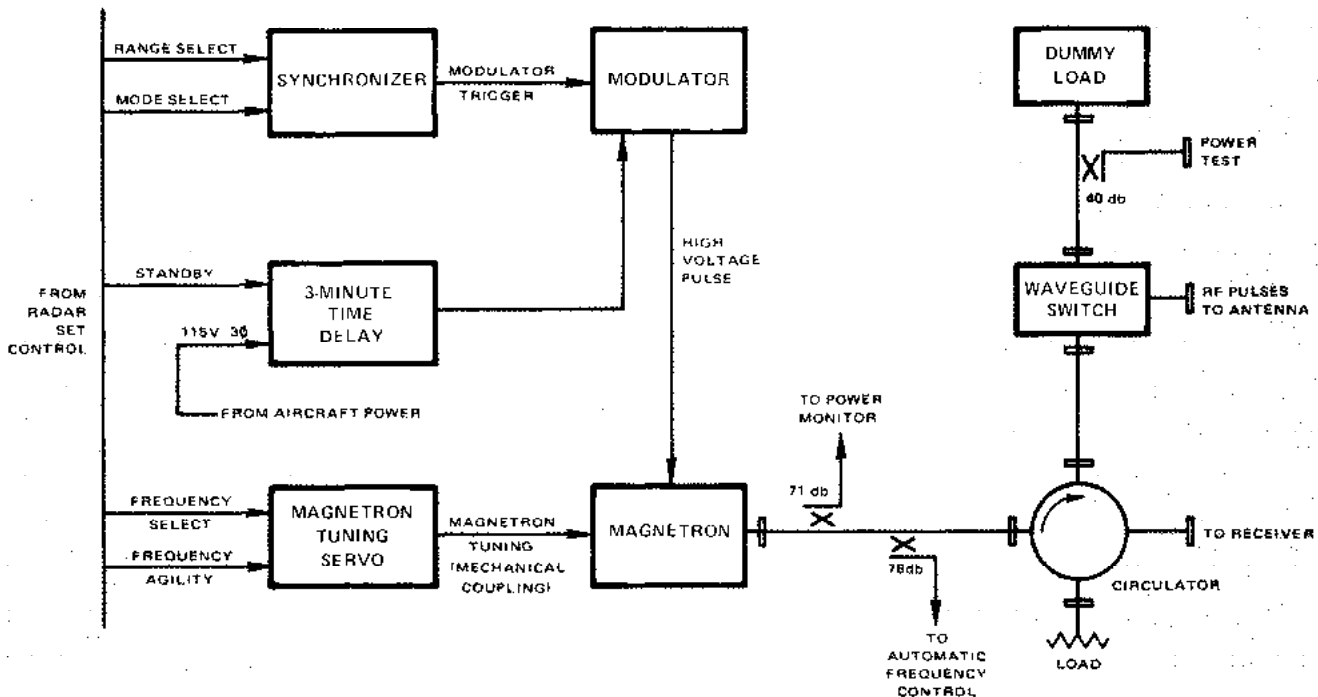

TRANSMITTER SYSTEM DIAGRAM

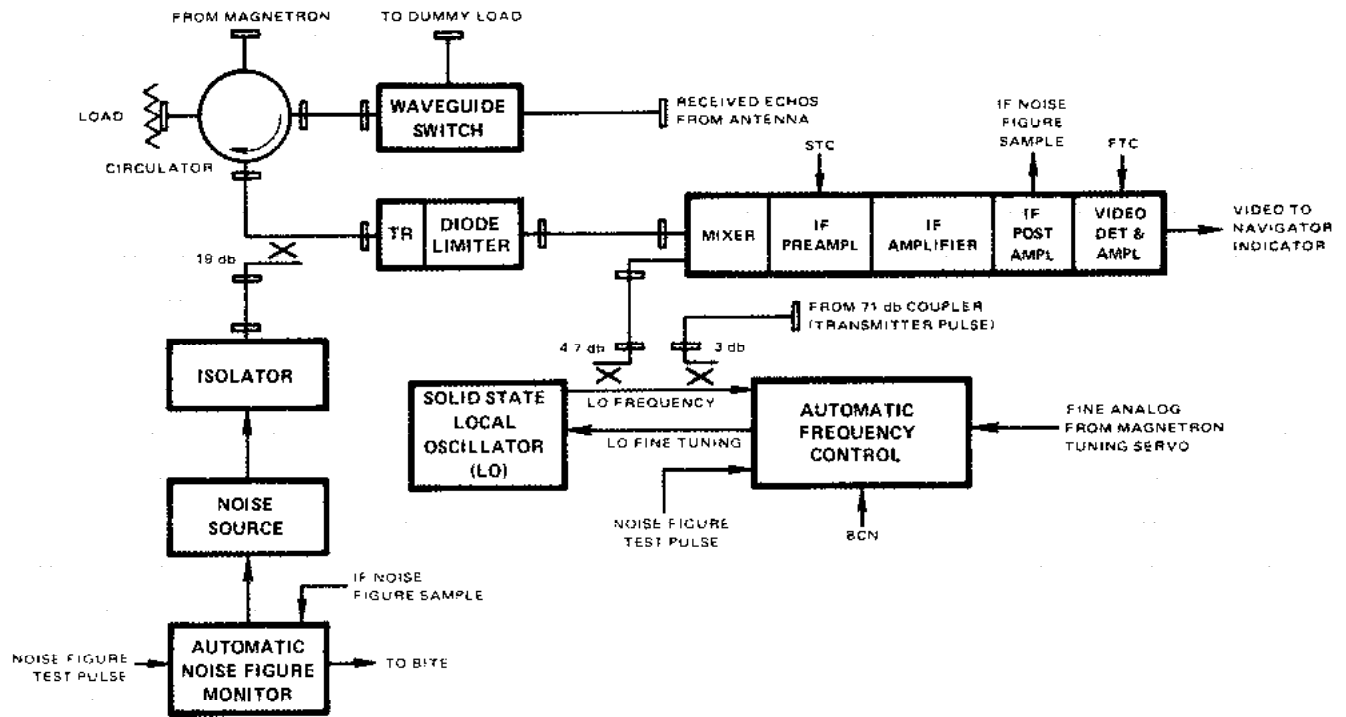

**RECEIVER SYSTEM DIAGRAM**

radar set control panel. The power going to the dummy load is picked off by a 40 db coupler and is made available at a waveguide test port for power measurement, PW, and PRF checks. A 71 db pick-off is used to monitor the power out. Should the peak power of the transmitted pulse fall below 30 KW, the power monitor generates a failure signal, the R-T FAIL light on the radar set control in illuminated, and the transmitter is shut down.

**Receive Mode:** The receiver is a superheterodyne type with a 60 MHz intermediate frequency (IF). The solid-state local oscillator is frequency tunable throughout the range of the receiver. In map and weather modes, the automatic frequency control (AFC) drives the local oscillator 60 MHz above the transmitter frequency. The AFC compares the coarse frequency analog and fine frequency analog signals from the magnetron tuning circuits and generates a DC voltage which tunes the local oscillator to the approximate magnetron frequency. The transmitter pulse from the magnetron is attenuated by 74 db and applied to a frequency discriminator in the AFC. The compared output of discriminator and coarse and fine analog signals generates a DC offset voltage which fine tunes the local oscillator to exactly 60 MHz above the transmitted frequency. When the beacon mode is selected, the local oscillator is crystal controlled to generate a frequency 60 MHz above the 9310 MHz signals received from radar beacon station.

The received echos are applied through the waveguide switch, the circulator, and a transmit-receive limiter to the IF mixer diodes. The T-R limiter is a passive device used to protect the mixer diodes from very strong echos such as are experienced from hangar doors and from nearby aircraft transmitting directly into the antenna. Though the T-R limiter is an adequate protective device, it is recommended that care be taken to transmit only away from nearby buildings and other aircraft to prolong the life of the mixer crystals which are inherently delicate devices.

The received echos are mixed with the local oscillator output to generate a 60 MHz IF signal. The resulting signal is amplified by a preamplifier and logarithmic post-amplifier to provide a gain of approximately 60 db.

The 60 MHz IF signal is detected, and the resulting video is supplied to the navigator's indicator where it is split: a pilot's video signal is sent to the sweep generator for further processing and final display on the pilot's indicator.

The sensitivity time control (STC) is a gain reduction device to cut down the amplitude of close-in targets which, due to their proximity, appear around the center of the plan position indicator or at the vertex of a sector scan, causing clutter and a large bright area. The STC

reduces the brightness of large close-in targets so that they are de-emphasized to allow targets at greater ranges to appear at approximately the same amplitude/brightness, provided they have the same reflectivity. STC can be considered as a modification of the fan beam to de-emphasize close targets. STC range and depth controls are provided on the radar set control. The STC range is variable from 0 to approximately 20 nautical miles. In the WEA mode the STC controls are inoperative and a fixed maximum STC is provided to 40 nautical miles.

Fast time constant (FTC) is a device used to break up video in the receiver to better accentuate hard targets and cut down on clutter. FTC breaks up signals of long duration, leaving less voltage amplitude as integrated by the display phosphor. This reduces the tendency of the signal intensity to "creep" on the phosphor, permitting sharper, more definitive outlines of complex targets and the virtual elimination of clutter.

Receiver noise is continuously monitored by an automatic noise figure monitor. During each transmit dead time, the noise figure generator sends a noise pulse through the receiver. Should the IF noise level be greater than the injected noise pulse level by more than 2 db, a receiver noise figure fail signal is generated, and the R-T fail light on the radar set control is illuminated.

A built-in test function of the R-T unit continuously monitors the following signals: power supply (+ 20

VDC), waveguide switch, power monitor (output), noise figure, master trigger, beacon mode, frequency select, AFC, AFC crystal 1, AFC crystal 2, IF crystal 1, and IF crystal 2.

A failure of any of the above causes the R-T fail light on the radar set control to illuminate. A test meter and switch are installed on the forward corner of the R-T. Should the R-T fail light on the radar set control illuminate, the test switch and meter indication on the R-T should be monitored to accurately determine where the failure has occurred.

### Indicator Subsystem

The indicator subsystem displays the video from the R-T unit on the 7-inch navigator's CRT and the 5-inch, pilot's direct view storage tube. The indicator subsystem includes the navigator's and the pilot's display systems.

**The navigator's display system** consists of the navigator's indicator, cursor control, and the radar set control.

The navigator's indicator processes the incoming video from the R-T and, using master trigger, range, mode, and scan select information, displays the video on the 7-inch CRT, requiring minimal front panel controls. To provide the processing, the navigator's indicator has the following functional loops: the timing generation loop, sweep generation loop, deflection and focus loop, video processing loop, and the power supply loop.

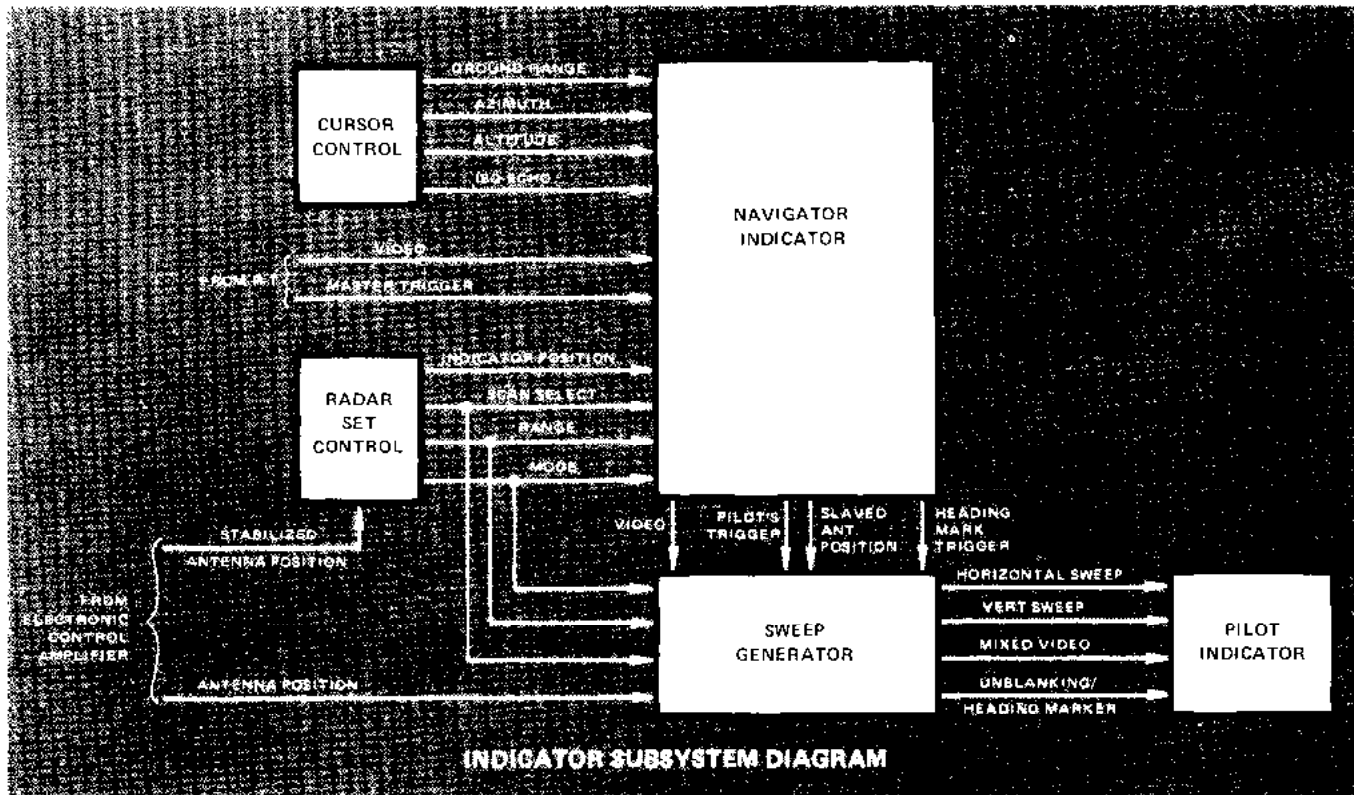

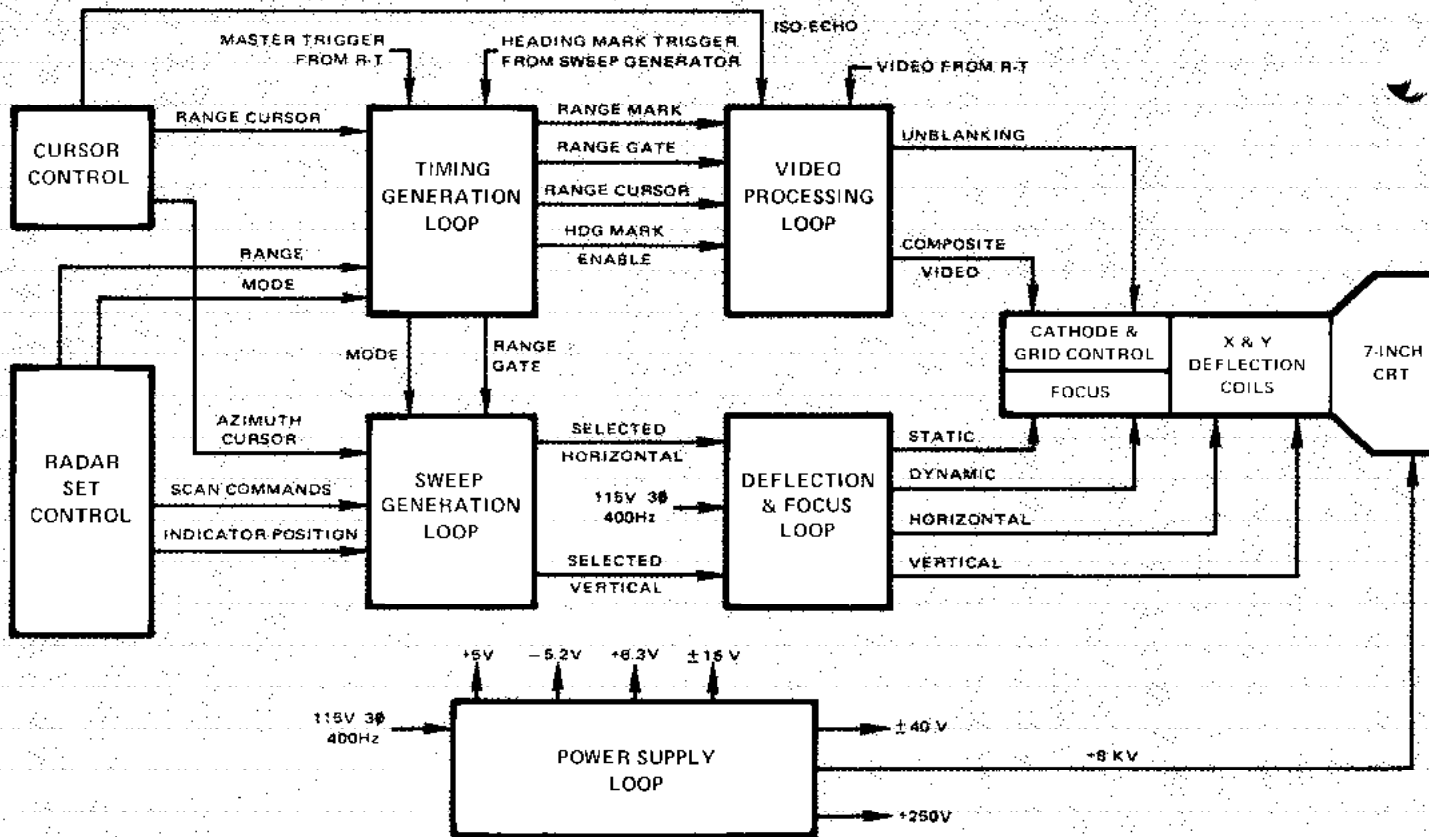

**NAVIGATOR INDICATOR SYSTEM DIAGRAM**

12

The timing generation loop generates the range gate. The range gate master trigger is derived from the transmitter and is used as time or range zero for the range gate. The range gate length is controlled by the range selection on the radar set control. A gate is generated which will be a positive pulse  $618 \pm 10 \mu s$  wide in the 50 nautical-mile range. The pulse width or the gated range is used to gate through video and to set up sweep lengths for the display.

The timing generation loop also provides the heading mark, range marks, and range cursor.

The sweep generation loop produces the selected horizontal and vertical sweeps, the lengths of which are directly proportional to the range gate. The horizontal and vertical sweeps are derived from antenna position information in the radar set control, which presents the position of the antenna relative to the azimuth stabilization that has been selected. Either magnetic north, or the aircraft's heading may be displayed at the top of the indicator screens.

The deflection and focus loop develops the horizontal and vertical sweep voltages which are applied to the CRT deflection yokes. This loop also produces the dynamic and static focus voltages required to focus the electron beam onto the face of the display. The video processing

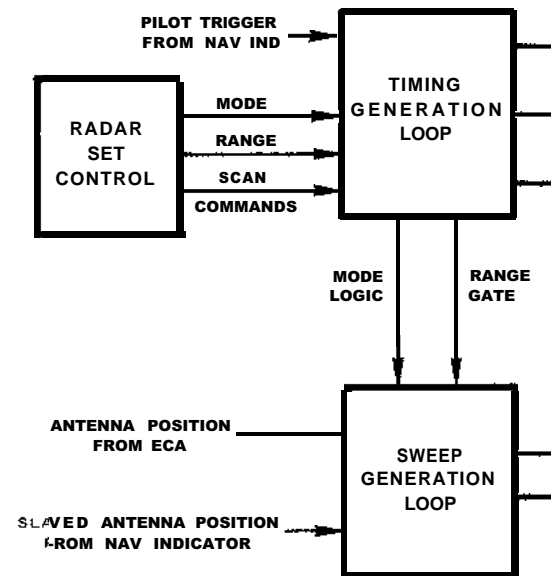



loop combines the raw video, the range marks, and the range cursor into a composite video signal, and applies this signal to the cathode of the CRT. The loop also generates an unblanking signal which is combined with the heading mark and azimuth cursor and applied to the control grid of the CRT. The unblanking signal is intensity-compensated to correct for the difference in selected ranges, pulse repetition frequency, and scan speeds.

The power supply loop generates the low voltage power required by the processing circuitry and the high voltage (+ 8 KV) power required by the CRT. The power supplies transform the low-voltage power from the 3-phase aircraft power which is applied through individual circuit breakers and line filters. The + 40 VDC output of the power supply is chopped at a 1.500 Hz rate and applied to the high voltage power supply to produce the +8 KV anode voltage for the CRT.

The pilot's display system is similar to the navigator's, but due to size restrictions at the pilot-copilot stations, the pilot's indicator is made as small as possible and most of the signal processing is done in the sweep generator unit.

The pilot's display system has the same loops as the navigator's display system, and some of the navigator's indicator and sweep generator printed circuit cards are interchangeable.

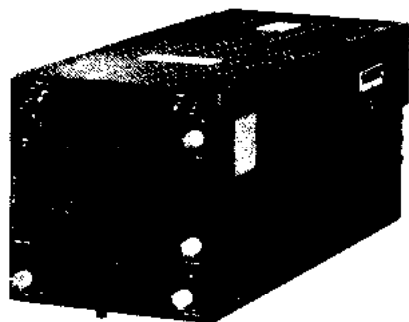
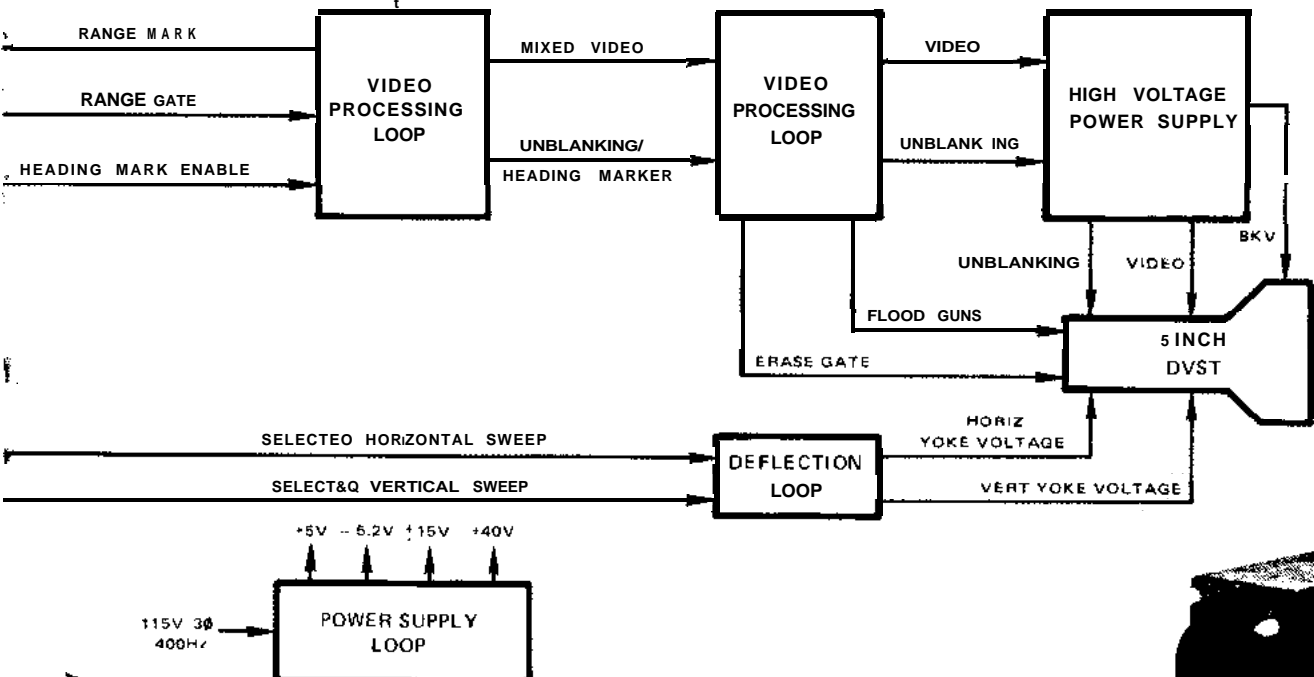

Photo courtesy of Texas Instruments.

**SWEEP GENERATOR**

VIDEO FROM NAV INDICATOR

**PI LOT INDICATOR**



**PILOT DISPLAY SYSTEM DIAGRAM**



Photo courtesy of Texas Instruments.

The timing generation loop, sweep generation loop, video processing loop and part of the low voltage power supply loop, together with the built-in test loop, are contained in the sweep generator. Additionally, direct view storage tube processing circuits and the deflection loop, together with low and high voltage power supplies, are contained in the pilot's indicator.

The pilot's video and the pilot's trigger are passed to the sweep generator from the navigator's indicator. The heading mark trigger is generated in the sweep generator and sent to the navigator's indicator. The pilot's indicator does not display the electronic cursors. It also must be slaved to the azimuth stabilization of the navigator's indicator in order to display north-up oriented information.

In the approximately two years that the APQ-122 radar system has been in service with the Hercules fleet, it has proved to be effective, versatile, and reliable. All solid-state construction and conservative engineering have

contributed to an outstanding record of dependability and low maintenance cost. In all respects of operation and maintainability, this system has proven to be a worthy replacement for the APN-59.

Of course no electronic system will remain trouble-free indefinitely, and also with the APQ-122 the time eventually comes when service is needed. In general, the servicing procedures for the APQ-122 are quite straightforward, but because the system is still relatively new, some customers are unsure of the best way to evolve efficient troubleshooting methods. To assist these operators in reducing the time required to service their APQ-122 radar sets and return their aircraft to operational status, we will present a special article on troubleshooting this system in an upcoming issue of Service News.



## GLOSSARY

14

If radar is not your speciality and it has been a while since you have studied electronics, the following glossary may be of some help.

**X-band** - A radar frequency band extending from 5,200 to 11,000 MHz.

**cursor** - A mechanical or electronically-generated movable line used as a reference to denote heading, azimuth, etc., on a radar indicator.

**loop** - In radar, the term loop is often used to define a series of circuits designed to perform a specific function: as in sweep generation loop, power supply loop, etc.

**trigger** -- A signal or pulse used to initiate action in another circuit.

**blanking/unblanking** - An electronic process in which the beam of a cathode ray tube is turned off or on.

**magnetron** - A specialized type of electron tube which is capable of producing high power RF energy in the microwave region of the radar band.

**waveguide switch** -- A switch in the transmission (waveguide) line which directs RF energy to one device or another.

**circulator** - A microwave coupling unit that has three or more terminals arranged in such a way that energy entering one terminal is transmitted to an adjacent terminal in a particular direction.

**frequency discriminator** - A device in which amplitude variations are derived in response to frequency or phase variations.

**DC offset voltage** -- The difference in DC voltage at two inputs of an operational amplifier required to bring the output voltage to zero.

**mixer** -- A circuit that generates output frequencies equal to the sum and the difference of two input frequencies.

**frequency analog** - A voltage which is equivalent to a given frequency.

**gate** - A circuit used as a switch or "gate" to inhibit or pass another signal.

**superhetrodyne** - A method of reception in which the received frequency is mixed with a local oscillator frequency to produce a fixed intermediate frequency which may be conveniently amplified and controlled.

**chopper** - An electronic device used to interrupt a DC signal at regular intervals to permit amplification by an AC amplifier.

**scintillation** - A "sparkling" effect in the display of a radar return signal caused by random ground objects peculiarly reflective to the transmitted radar frequency being used.



# upper cowling hinge lubrication

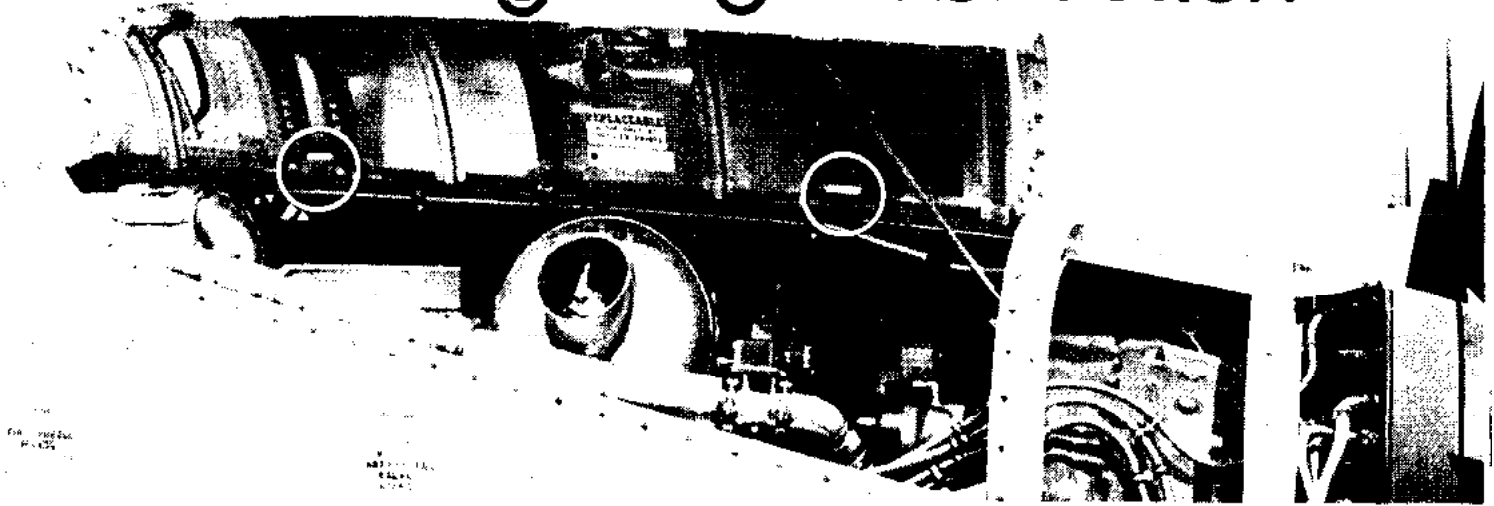

by W. C. Barre, *Service Representative*

If you have experienced difficulty lubricating the pins in the Hercules QEC center beam hinge, here is an idea which may be helpful.

Access to the top of the Hercules' engine accessory section is provided by two hinged panels in the engine nacelle cowling. Two hinges for each panel are bolted to the nacelle center beam, and Paneloc fasteners along the opening edges secure these panels in the closed position. The panels can be removed after opening by pulling the hinge pins; each pin is secured with a castellated nut and a cotter pin.

These removable pins receive a dry film lubricant in production, and as a rule this is all they need until removal of the QEC. No periodic schedule is specified for lubricating these hinges between overhauls; therefore, operating conditions and the inspection schedule set by the Hercules operator should determine when the hinges are to be serviced.

To lubricate the hinges, the usual procedure is to pull the pins and remove the panel. After the pins and hinges are cleaned and lubricated, installation steps are in reverse order of removal. The difficulty comes with aligning both hinges at the same time to install the pins. Each upper cowling panel weighs over twenty-two pounds. This doesn't seem heavy until you try a one-man balancing act to install one of them.

Two Hercules operators have eliminated the necessity of removing the pins and panels for this job by installing a standard grease fitting in the center of each hinge. This is illustrated in Figure 1. The fittings allow use of a standard grease gun to apply an aircraft general-purpose lubricating grease such as MIL-G-21 164 or MIL-G-33827. The latter specification replaces MIL-G-77 11 which may still appear in some manuals.

Installation of the grease fittings is at the option of the operator. Lockheed has no plans to install grease fittings in these hinges in production because problems with the hinges in the field have been minimal.

**SERVICE NEWS**

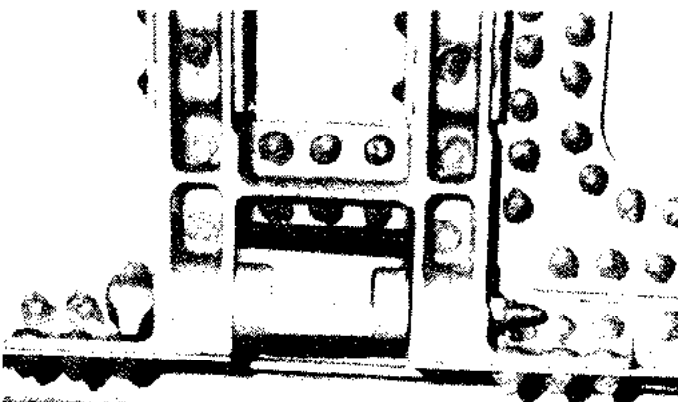

Figure 1 Production installation of a cowling hinge with pin. Dry lubrication is standard.

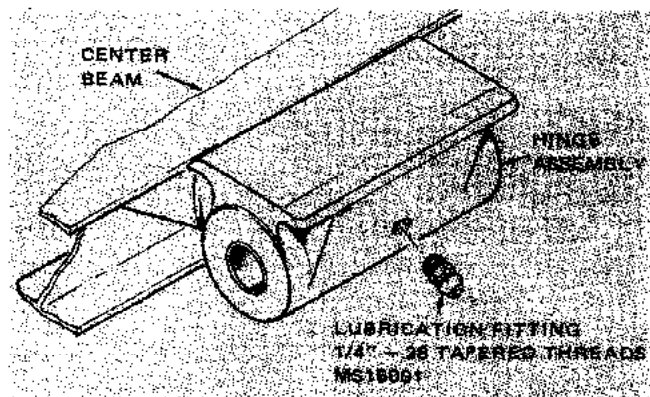

Figure 2 Hinge modified to allow lubrication with grease.

# AC Voltage Regulators

Some Hercules operators have asked which voltage regulator is to be used with which AC generator. The following list of generators and their matching voltage regulators should answer most of these questions.

Generator	Voltage Regulator
A50J207-4 Westinghouse Brush Type	A40A1750
976J480-2 Westinghouse Brushless	A40A1750-2
28B58-9-A Bendix Brushless	20B95-4-A
2CM353CID/H General Electric Brushless	3S2060DR113A1
3 1220-004 Lear Siegler ATM Brush Type	51107-003

Any of the following generator control panels can be used with any of the generator and regulator combinations listed previously.

## Type G1

AERNO 42-0731 (USAF)

Westinghouse  
P/N A35A9140

Westinghouse  
P/N A40A1735

Westinghouse  
P/N A40A1735-2

## Type PEU-25/A

AERNO 42-0735 (USAF)

General Electric  
P/N 3S2060DC102D1

## Lockheed

P/N 3402292-1

A mismatch of a generator and a voltage regulator will result in voltage regulator failure because of the differences in the designed interaction between generator and regulator. Extra precautions are necessary for Hercules operators having a mix of airplanes that may use more than one type of generator.

Effective at serial LAC 4733 and up, certain versions of Hercules airplanes incorporate the Bendix brushless generator (P/N 28B58-9-A) and its matching voltage regulator (P/N 20B95-4-A) in lieu of General Electric or Westinghouse. On these airplanes precautions have been taken to prevent mismatch. Caution decals are installed on the Bendix components and on the aircraft structure.

16

AC voltage regulators on the electrical control and supply rack just forward of the 245 bulkhead.





# Hercules MLG Ballscrew Lube

## side lubrication fitting modified

by C. R. Bush, *Design Engineer Specialist*

The Calco 8353 main landing gear ballscrew assembly has been installed on Hercules airplanes subsequent to serial number LAC 4547 and is the preferred spare for all Hercules. It is normally very reliable and has given good service. However, as with any mechanical device, there have been some failures. This article discusses the major cause of these failures and the preventive action.

Premature failure of Calco ballscrews was experienced by one operator during Arctic operations. The ballscrews were analyzed by the manufacturer and his report indicated that the failure was caused by excessive grease in the ball nuts. An excessive amount of grease, coupled with low temperatures under Arctic conditions or at altitude during flight, can cause a problem in that the grease may stiffen sufficiently to impede motion of the internal balls. This motion restriction, plus a light bearing load condition, tends to cause the balls to skid rather than roll. Skidding can cause ball flat-spotting and resultant damage to the thin chrome plating on the screw and the nut.

On Hercules aircraft serial number LAC 4669 and up, and on spare Calco 8353 ballscrew assemblies shipped after May 10, 1976, the lubrication fitting on the side of the ball nut is modified to exclude the spring and ball. This provides a path through which excess grease can be expelled from the ball nut during gear operation.

Field modification of the MS1 5001-1 side-mounted lubrication fitting to provide similar protection against the build-up of excessive amounts of grease is also recommended: Remove the fitting (Figure 1) from the ball nut (accessible from the wheel well) and file away the base of

**Figure 1**

**ACCESS TO BALL NUT GREASE FITTING BEHIND STRUT.**

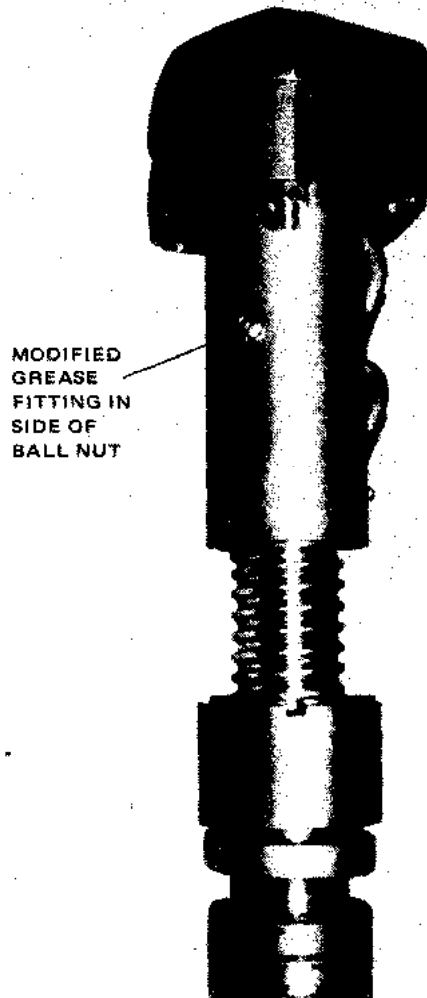
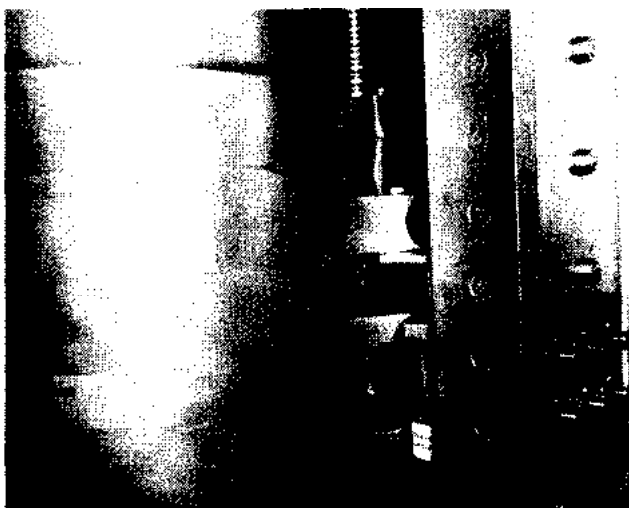

**Figure 2** BALL NUT AND SCREW ASSEMBLY.

the fitting in order to remove the spring and ball. Discard the spring and ball and reinstall the fitting after careful cleaning.

Operation of a ballscrew with its circulating balls is similar to that of a ball bearing, in that only a third of the available volume should be filled with grease. Using a hand-operated grease gun, lubricate the ball nut with four "shots" of MIL-G-23827A grease (Aeroshell 7 or equivalent) at each 200-hour "B" check. MIL-G-21164C grease (Aeroshell 17 or equivalent) is no longer recommended for this application because of its tendency to separate and dry out. The lubrication fitting on top of the ball nut lubricates only the mounting flange on the outside of the ball nut and it is not modified.

**SERVICE NEWS**

# SPARE NUTS for V-BAND COUPLINGS

The sections of the bleed air ducts in the Hercules and JetStar are connected by V-band couplings, sometimes called Marman clamps. While the major use for the V-band couplings is on the bleed air ducts of the pneumatic systems, they are also used on other components. These couplings are practically trouble free if they are installed according to the instructions in the aircraft maintenance manual and/or T.O. 1-1A-8 Structural Hardware.

The nuts used to tighten the clamps on the V-band couplings may, in time, become worn or damaged and need replacing. While the nuts are relatively inexpensive, they are of unique design - special for this application. In many cases, it has been necessary to replace an otherwise serviceable coupling assembly because a spare nut was not in the local inventory. Substitution with a nut which does not meet the specification of the original nut is not allowed.

The price of a nut can save the cost of a coupling assembly. Also, stocking spare nuts in both sizes may save considerable time. Tag them to prevent mixing with other nuts which may be similar only in appearance ■

The stainless steel, silver-plated nuts that come with these couplings have a castellated appearance as a result of cuts made in the top to allow a self-locking spring action.

While this article does not cover all couplings nor detail their installation, we have listed the part numbers for the two nuts used for the majority of V-band couplings.

Nut Part Numbers	Size
A1200J-02	10-32
Z1200J-048	1/4-28

**SEVICO NEWS**

## StarTip

### Boost Pump Electrical Connector

We have received several field reports concerning pins shorting in the electrical receptacle for the suction boost pump. This is apparently due to poor mating of the aircraft electrical plug and pump electrical receptacle, which allows contamination to collect around the base of the pins.

The wiring diagram for the hydraulic suction boost pump has been changed to reflect an environmental plug, P/N MS3108R18-4S, in lieu of the standard P/N MS3108B18-4s plug. If aircraft at your facility are experiencing burnt pin problems at the suction boost pump connection, we recommend installing the P/N MS3108R 18-4s plug.

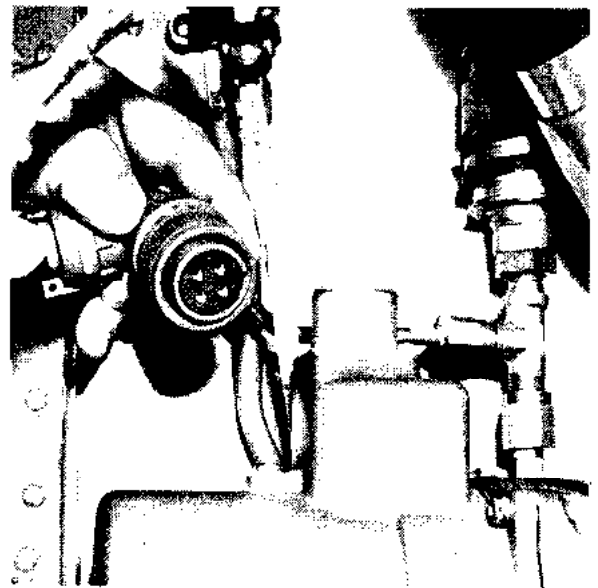

New environmental plug for hydraulic suction boost pump.

# KC-130R Flight Simulator

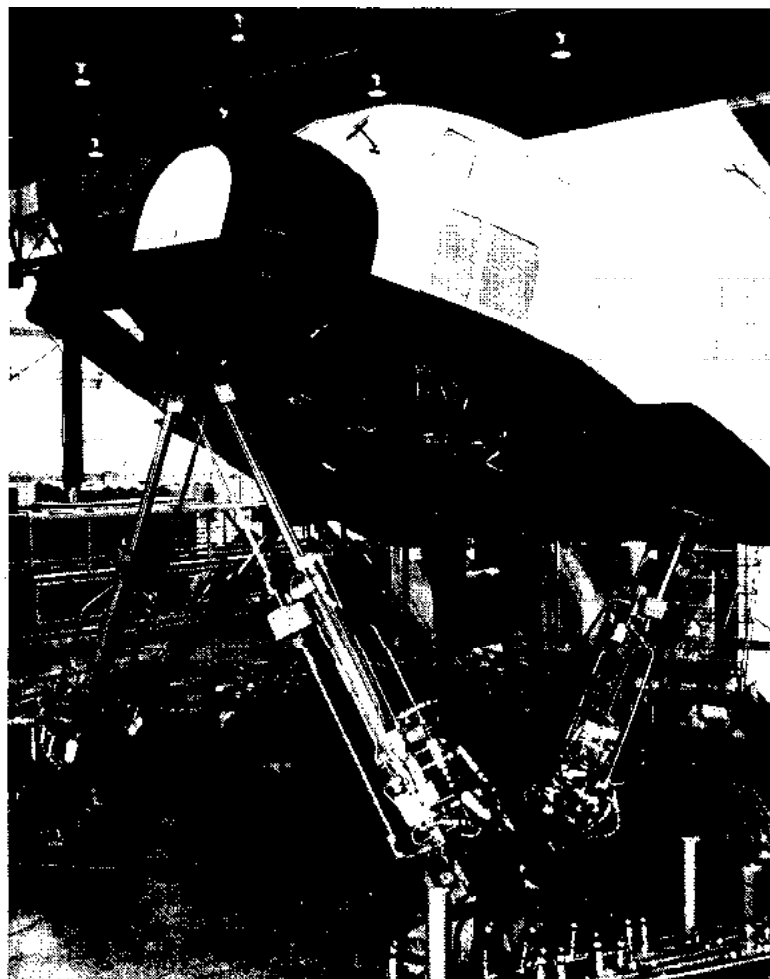
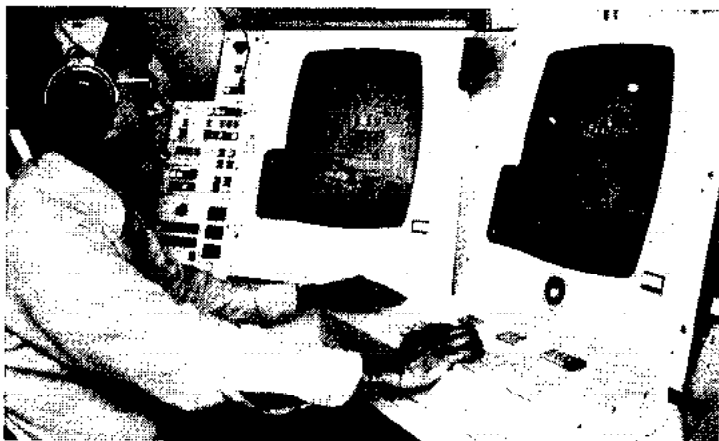

ABOVE: The KC-130R Hercules simulator in a nose up attitude. LEFT: Instructor's station for the Hercules simulator.

*Photos courtesy of The Singer Company.*

Operation of the complex modern-day airplane requires skills which must periodically be monitored and reinforced through training. Much of this training is accomplished with aircraft flight simulators which have gained an increasingly important role in the training programs of both commercial and military operations. The use of a flight simulator in lieu of an actual aircraft offers distinct advantages; safety, cost, schedule flexibility, and versatility in training missions.

The U. S. Marine Corps operates KC-130F and KC-130R tanker aircraft and their flight crew personnel receive training on flight simulators designed and built by the Singer Company. A KC-130F simulator is being modified for use as a Cockpit Procedures Trainer (CPT) while another KC-130F simulator is being updated to the KC-130R configuration.

The CPT will have full systems capability with the exception of radio and navigational aids and will be able to simulate 200 different malfunctions.

The KC-130R flight simulator will be capable of simulating up to 900 different malfunctions and will employ the latest state-of-the-art features such as a six-degree-of-freedom motion system with a visual display. In addition to the normal features, it will also simulate such things as turbulence, rain, hail, and wind shear. Of special importance to inflight refueling operations, the simulator will be capable of depicting airborne rendezvous between the tanker and the receiving aircraft. Progress and responses of the crew can be monitored on a video system with slow motion and instant replay capabilities.

Training is provided by the Simulator Section of the 3rd Marine Air Wing MAWTUPAC (Marine Air Weapon Train-

ing Unit Pacific), at El Toro, California. The Officer-In-Charge of the Simulator Section is Captain F. B. Smith. The El Toro simulator facilities are also used to train personnel from other organizations such as the U. S. Coast Guard and the U. S. Navy.

Among the different training courses conducted at the facility are basic C-130 pilot familiarization, refresher pilot training, squadron quarterly emergency procedure reviews, and a ground school and simulator training for flight engineers. The KC-130F/R training supplied by the 3rd Marine Air Wing is a valuable asset to the successful operation of the Marine Corps' C-130 fleet and demonstrates the effectiveness of simulator training.

**SERVICE NEWS**

CUSTOMER SERVICE DIVISION  
LOCKHEED-GEORGIA COMPANY

A DIVISION OF LOCKHEED AIRCRAFT CORPORATION  
MARIETTA, GEORGIA 30053



**U.S. Marine Corps KC-130R Hercules and  
flight simulators. See page 19.**