

# *SERVICE NEWS*



**HTTB**



A SERVICE PUBLICATION OF  
 LOCKHEED-GEORGIA COMPANY  
 A DIVISION OF  
 LOCKHEED CORPORATION

*Editor*  
 Charles I. Gale

*Associate Editors*  
 Doug Brashear  
 James A. Loftin  
 Vera A. Taylor

*Art Direction & Production*  
 Teri L. Mohr

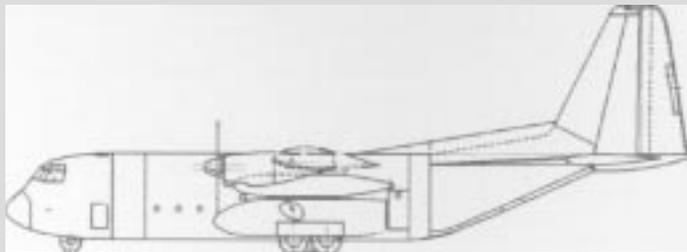
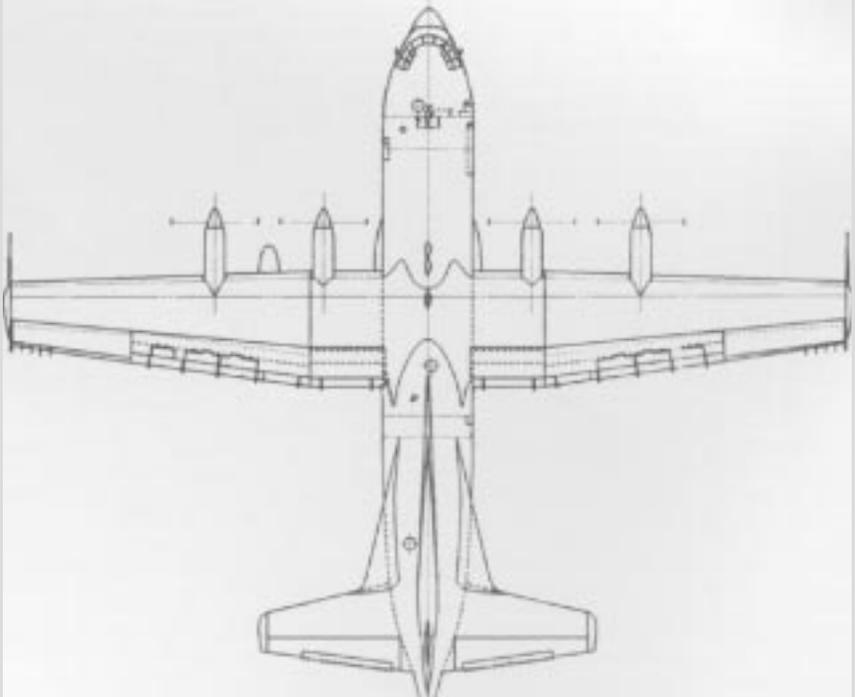
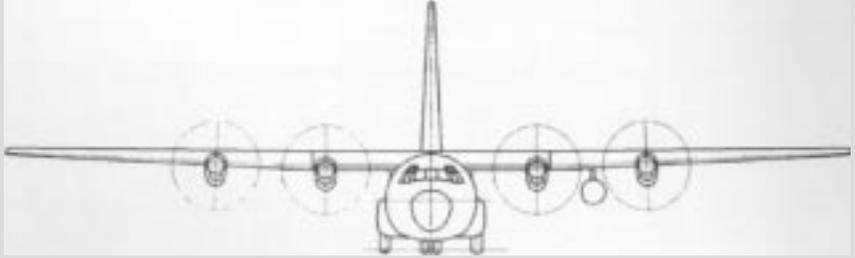
Vol. 12, No. 3, July-September 1985

**CONTENTS**

- 3 **HTTB-The High Technology Test Bed**  
 Lockheed's unique, flying laboratory enters service.
- 14 **Very High Pressure Hydraulics: It's Here**  
 Systems using 8000 psi pressure, nonflammable fluid are now being tested.
- 15 **New Lockheed-Designed Syncrophaser Test Sets**
- 18 **Hercules Flap System**  
 A review of the major components and system operation.
- 22 **Main landing Gear Friction Washer Splash Guard**

Cover: Distinctive in both appearance and purpose, this specially modified Hercules aircraft is Lockheed's new High Technology Test Bed, featured in this issue.

Published by Lockheed-Georgia Company, a Division of Lockheed Corporation. Information contained in this issue is considered by Lockheed-Georgia Company to be accurate and authoritative: it should not be assumed, however, that this material has received approval from any governmental agency or military service unless it is specifically noted. This publication is for planning and information purposes only, and it is not to be construed as authority for making changes an aircraft or equipment or as superseding any established operational or maintenance procedures or policies. The following marks are registered and owned by Lockheed Corporation: "Lockheed," Hercules; and "JetStar." Written permission must be obtained from Lockheed-Georgia Company before republishing any material in this periodical. Address all communications to Editor, Service News, Department 64-31, Zone 278, Lockheed-Georgia Company, Marietta, Georgia, 30063. Copyright 1985 Lockheed Corporation.



**PRODUCT SUPPORT**

LOCKHEED-GEORGIA COMPANY  
 MARIETTA, GEORGIA 30063

**M. M. HODNETT                      DIRECTOR**

**CUSTOMER SERVICE**

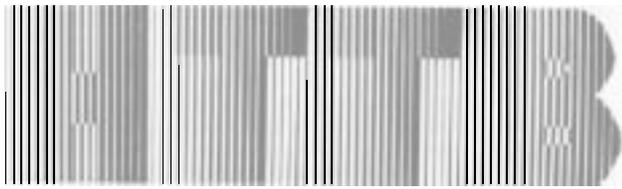
**A. H. McCRUM  
 DIRECTOR**

**INTEGRATED LOGISTICS SUPPORT**

**J. L. THURMOND  
 DIRECTOR**

**CUSTOMER SUPPLY**

**H. T. NISSLEY  
 DIRECTOR**



# The High Technology Test Bed

Aeronautical systems must be tested and proven to much more stringent standards than typical ground-based systems. The most important test to establish the function and credibility of a system is the test flight. To satisfy the ever-increasing need to test or enhance the development of new systems and systems concepts, the

Lockheed-Georgia Company has dedicated an aircraft to the specific support of independent research and development projects, as well as Lockheed research and technology contracts. This aircraft is designated the High Technology Test Bed (HTTB).

In the past, the absence of such a facility has sometimes

impeded the process of getting new systems from the drawing board to installation on production aircraft. Substitution of expensive simulation facilities for the flight environment does not always yield satisfactory or reliable results. The use of models to analyze problems has many limitations and often introduces test effects which can appear as significant as the phenomena being observed. Other difficulties encountered in working with models or simulations have to do with the prediction of scale effects—a complex business at best—and test support interference effects.

In evaluating independent research and development programs at Lockheed-Georgia, it was found that more than 50 of them would benefit greatly from evaluation done in a flight environment. Significantly, these projects are from a variety of technology areas, and include such subjects as enhanced short takeoff and landing (STOL) capabilities, survivability improvements, advanced flight station design, and new avionics systems.



## OBJECTIVES

Some performance and mission objectives for the HTTB were established on the basis of what are believed to be the technological and performance requirements of the next-generation tactical airlifter. Among other things, the goal of the HTTB program in this context is to help develop the capabilities that will allow the aircraft to fly to a target location anywhere in the world using passive navigation; that is, without assistance from ground or satellite navigation aids. Upon reaching the target area, the aircraft must be able to perform as follows:

- Fly an approach at 75 to 80 knots, using onboard-generated centerline and glidepath (up to 7 degrees) guidance, in all weather conditions.
- Clear a standard 50-foot obstacle and touch down on a soft field (not a paved runway) within 4 feet laterally and 20 feet longitudinally of a predetermined spot, with a descent rate of around 10 feet per second.
- Have a landing distance not exceeding 1500 feet from the base of the 50-foot obstacle.

All of this, by the way, is to be done on a hot day at a gross weight of 140,000 pounds.

## THE AIRCRAFT

As a result of these and other requirements, a Lockheed Model L-100-20 was acquired from a commercial operator. Delivered in February of 1984, the aircraft had approximately 5900 hours total time and was in excellent condition. The stretched civilian Hercules aircraft was chosen for the job because of its proven reliability. Another consideration was that large quantities of data exist to establish the norms needed for evaluating effects of new systems concepts and modifications. Also, the extra 100 inches of fuselage length on the L-100-20 means added space for test equipment and monitoring systems instrumentation.

## INITIAL MODIFICATIONS

The first step in the modification program was to convert the aircraft from a cargo hauler to an engineering test bed. To facilitate this, the Lockheed Airborne Data System (LADS) was installed. This is one of the more significant modifications built into the HTTB for experimenters. LADS has been developed over the last decade and is constantly being refined and improved. The purpose of this system is to process data in a rapid, reliable, and cost-effective way. The system has performed exceptionally well, and has already more than paid for its own hardware and development costs.



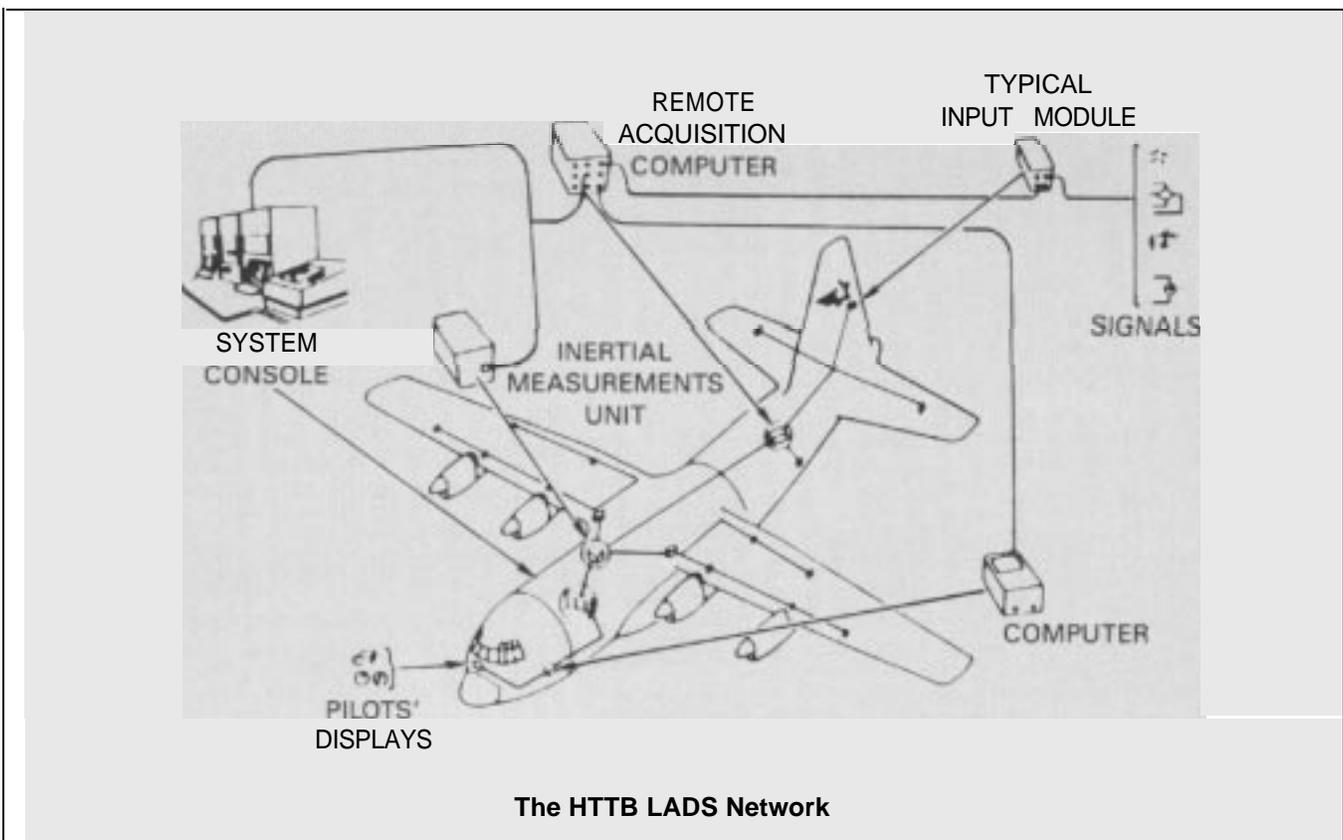
With the LADS, test data is available for study almost immediately after a data point is flown.



The instrumentation contains engineering unit displays, time code generators, telemetry transmitters, tape recorders, a power distribution network, and two minicomputers. The system is modular and has more than 1000 data channels available. In-flight data is gathered using thousands of feet of wiring installed to connect the instrumentation to virtually every significant location on the aircraft. Exceptional care has been taken to ensure that electrical noise is isolated and rejected at the source, allowing sensors, wires, and necessary input modules to provide a high-quality digital data signal. This yields a system that is quiet and accurate. As a result of this installation, the flight test engineer has hard-copy, finished and plotted data available moments after a data point has been flown.

Other modifications accomplished to enhance the aircraft's capabilities as a flying test bed are as follows:

- **An avionics equipment rack** and an instrumentation console were added in the cargo compartment in such a manner as to allow the total cargo area of the aircraft to remain available for test purposes.
- **Two additional stations** were added on the flight deck: one for the flight test avionics engineer, the other for the flight test director.
- **A bus interface** was developed to permit LADS to



---

extract data from MILSTD-1553B and ARINC 429 data busses. The purpose of these busses is to sort out the priority data to be transmitted from the various sensors so that the hard-wired connections to the Central Processing Unit (CPU) can be optimized.

• A **special on-board structural computer (OBSC)** system was installed to perform individual aircraft tracking (IAT) in real time, using inputs from dedicated strain gages and accelerometers.

• A **state-of-the-art airspeed measuring system**, angle of attack, and angle of sideslip measuring vanes were installed.

• A **cockpit management system (CMS)** was added to provide additional panel area for the new avionics systems and to alleviate crew workload. The Collins CMS 80 system that was selected is digital data bus compatible.

• The **HF and VHF communications equipment** was interfaced with the CMS, and the VHF radio was upgraded for improved tuning.

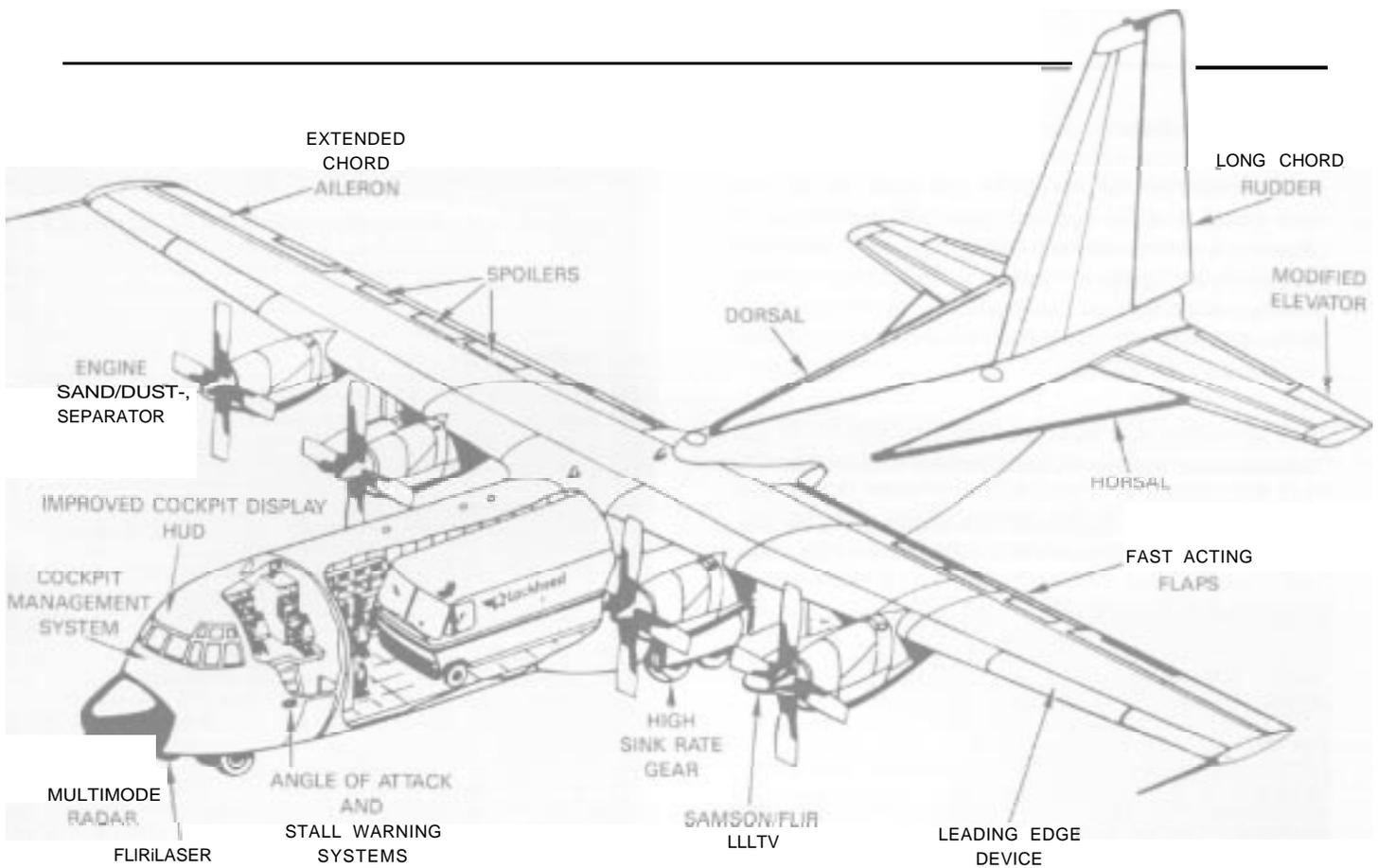
• A **Delco Carousel IV inertial navigation system (INS)** was installed and interfaced with the CMS.

• A **Honeywell LASERNAV INS** was installed for evaluation.

• The **weather radar system equipment** was upgraded.

Following the initial modifications to the HTTB aircraft, 120 flight hours were logged over 41 flights for the purpose of establishing and recording the flying qualities of this particular airplane. A total of 81 simulated assault-type landings were made by four different pilots at 1.28 times stall speed and a descent rate of 650 feet per minute on VFR approaches. This reference data will be utilized in the future to determine the improve-





Many of the HTTB's structural modifications are designed to enhance STOL performance.

ments in performance offered by each of the many modifications to be made to the aircraft.

### STOL MODIFICATIONS

As a result of wind tunnel testing and other research, a number of modifications to the basic aircraft that will enhance its short takeoff and landing characteristics have been or are scheduled to be made. Some of these modifications are:

- New **double-slotted trailing edge flaps** to provide increased lift as well as increased drag at approach power settings for improved STOL operations.
- A **high-camber leading edge extension** has been tested and proven to be quite effective in increasing maximum lift coefficient, both in landing and cruise configurations.
- A **larger dorsal fin and horsal fins** (extensions of the horizontal stabilizer leading edge root fillet - see illustration above) were installed to improve low speed handling qualities and control. These devices are approximate-

ly 5 feet in maximum span and have a root chord that extends almost to the wing trailing edge.

- **The primary flight control systems** are being changed from the present configuration, which consists of direct mechanical linkages assisted by hydraulic boost, to "fully powered" controls, in which the mechanical linkages from the flight station controls operate only the hydraulic control valves of the appropriate boost units.
- **Three spoiler panels** are to be added to the upper surface of each wing to improve roll control at low airspeeds, roll stability augmentation, and precise descent control. Asymmetric deployment of the spoilers will approximately double the roll control capability of the ailerons at low engine power and achieve even better performance as power is increased to levels used for STOL landing approaches. For descent control, the spoilers are deployed symmetrically. For safety, the spoiler deflection is automatically decreased as stall speed is approached. The spoiler actuation system is truly a high-technology system, featuring an 8000 psi hydraulic system, direct-drive valves, nonflammable chlorotrifluoroethylene (CTFE) fluid, and control intelligence provided

by the flight control computer.

- **For improved roll sensitivity**, the throw of the control wheel is to be reduced from 120 degrees to 70 degrees. Roll response with full control wheel input will approach 30 degrees of bank in **2.5** seconds in landing configuration. This is made possible by the improved roll control offered by extended chord ailerons combined with spoiler deflection.

- **The rudder and elevator trim tabs** will no longer operate in the manner we have become used to. The tabs will be actuated by a brushless DC motor, which gets its orders from the flight control computer. The tab surfaces on the HTTB perform a different function than their predecessors. These tabs serve to aid the hydraulic boost unit in moving the control surfaces when inputs are received from the flight station, and are considered as a part of their respective primary flight control systems.

- **Stability augmentation** for the yaw and pitch axes is accomplished by “smart” actuators directed by the flight control computer. The dual rotary actuators mechanically position the hydraulic control valves of the flight control boost units as commanded by the computer. As a result, stability augmentation is accomplished by movement of the entire control surface rather than just moving the tabs. This should allow the stability augmentation system more authority in low-speed flight. Stability augmentation in the roll axis, as mentioned earlier, will be accomplished by the multi-mode spoiler system and orchestrated by the flight control computer.

- **A long-stroke main and nose landing gear system** is being developed that will allow a sink rate of up to 15 feet per second. This will allow the HTTB to make precision landings on short and unprepared fields.

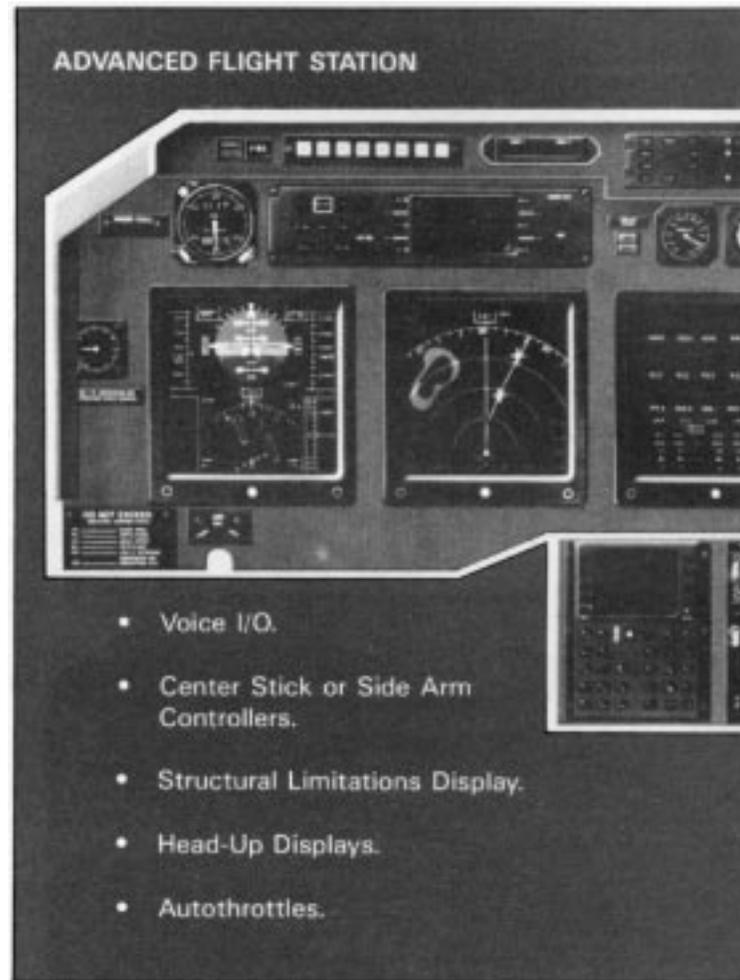
#### OTHER KEY MODIFICATIONS

- **A special syncrophaser system that** features adjustable phase angles.

- **A strap-on autothrottle system** designed by Lockheed for easy retrofit to existing C-130 aircraft. As it is currently configured, it is usable only during cruise flight, but evaluations will be made for its potential use during conventional and STOL approaches.

- **Additional engine instrumentation** for determining engine health in flight is being installed.

- **Linoflex couplings** of a new design are being installed as replacements for several of the Wiggins couplings in the fuel system for evaluation purposes.



#### ADVANCED FLIGHT STATION

Major modifications to update the flight station are also taking place. A “soft” mockup has been constructed which depicts the structural modifications to the instrument panel, control column, and control wheel that are necessary to install a CRT display system. A head-up display (HUD) system is under development for the pilot side of the cockpit. The STOL laws developed for the HTTB and proven on the flight simulator at the Manned Vehicle Systems Laboratory will be programmed into it.

#### SURVIVABILITY IMPROVEMENTS

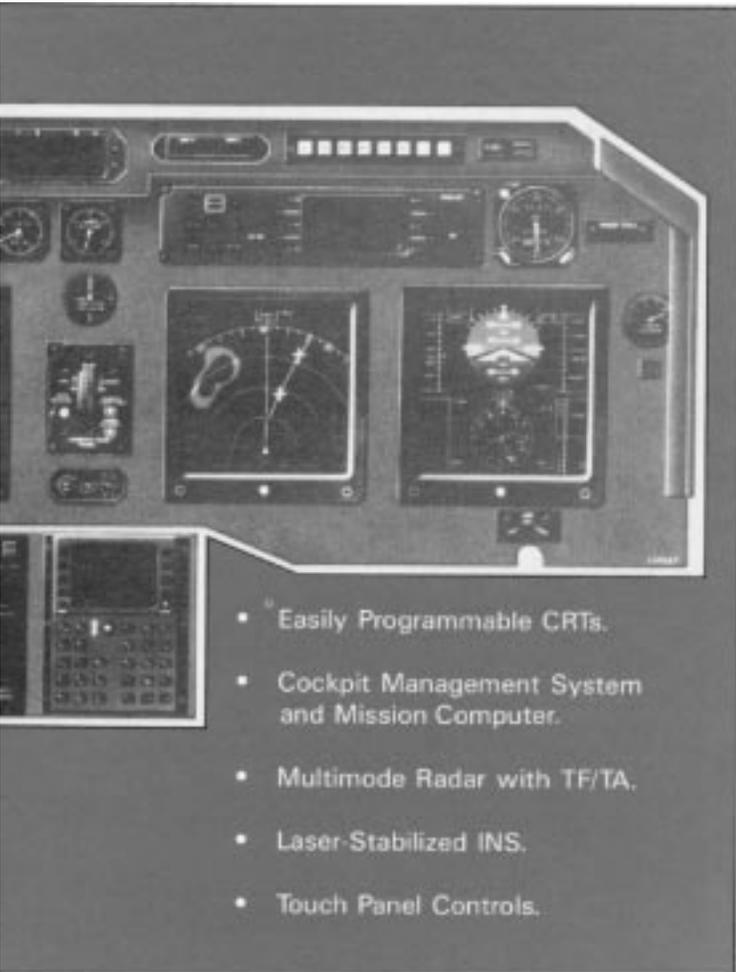
Improvements that will increase the aircraft’s ability to negotiate hostile environments will be studied and tested on the HTTB aircraft. Improvements will be investigated in two areas:

1. Prototype installations of survivability enhancement systems such as electronic countermeasures (ECM) and infrared/radar signature reduction equipment will be flight-tested on an instrumented electronics range. Results will be compared with simulation data to verify system operation.

2. To enhance C-130 systems survivability, several areas are being studied for incorporation on the HTTPB.

- To reduce propulsion system vulnerability to high-explosive incendiary (HEI) projectiles that would sever throttle cables, it was found that a combination of new throttle tension regulators and backup electric throttle actuators reduces the vulnerability contribution of the throttle system.

- To reduce fuel system vulnerability in the area of the dry bays located adjacent to the fuel tanks, the use of Halon gas was the most effective approach studied to prevent fires resulting from HEI ballistic impacts that may tend to ignite fuel that has spilled into the dry bay as a result of fuel tank punctures.



- Easily Programmable CRTs.
- Cockpit Management System and Mission Computer.
- Multimode Radar with TF/TA.
- Laser-Stabilized INS.
- Touch Panel Controls.



- The addition of a third, full-time hydraulic system to supply the flight controls system and redistribution of hydraulic power for flight controls offers a significant improvement in C-130 survivability.

The analysis, simulation, flight testing, and evaluation that will be performed in the HTTB program will enhance the development of survivability improvements, not only in the systems of currently manufactured aircraft, but those of future aircraft designs.

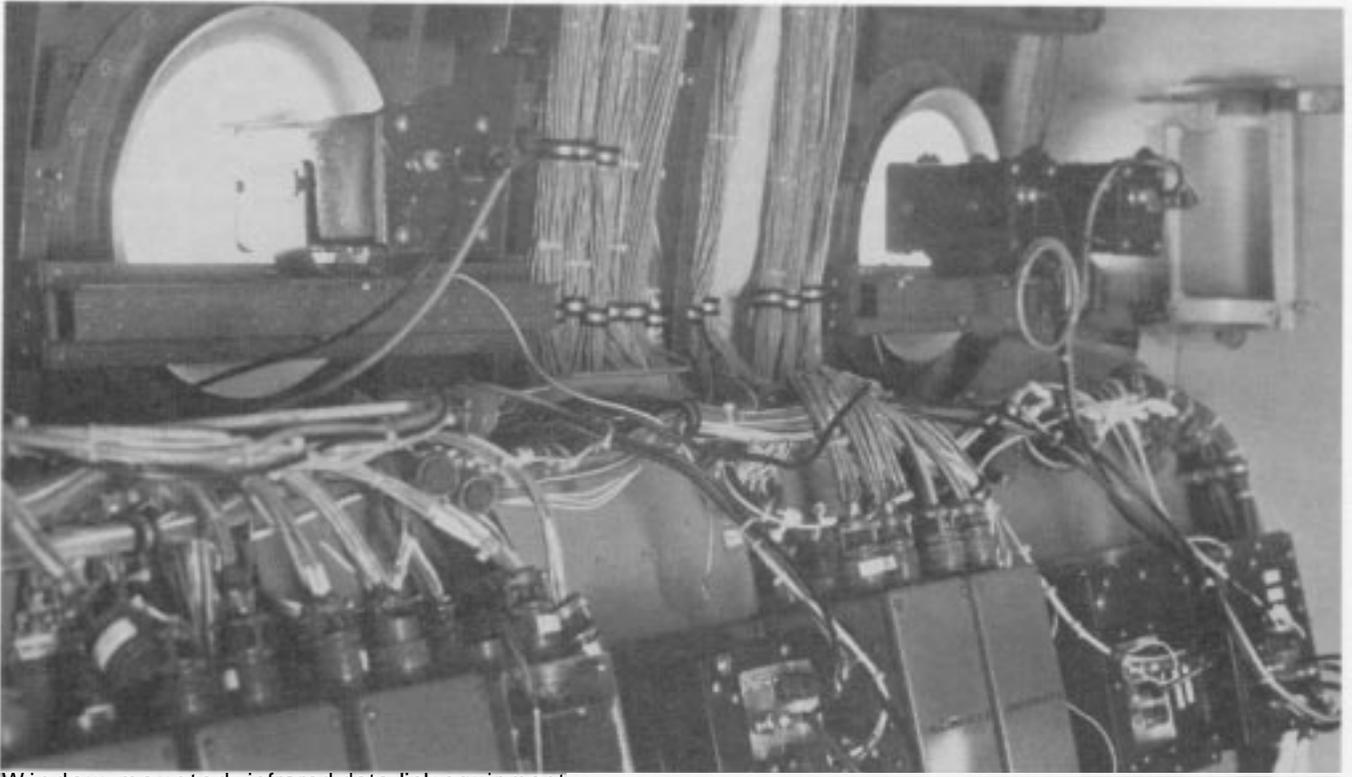
### **SAMSON POD**

One of the independent research and development projects to be evaluated on the HTTB aircraft is the SAMSON pod. The SAMSON (Special Avionics Mission Strap On Now) pod is a 25-foot long 1360-gallon

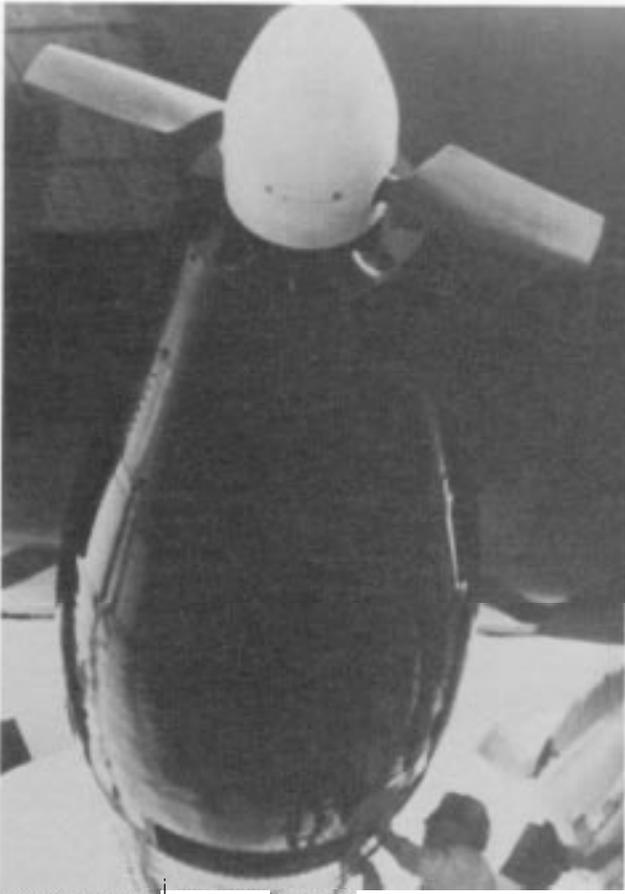
external fuel tank, modified to accommodate an easily attachable self-contained avionics package. A standard C-130 external fuel tank was chosen for this application because of its availability, known aerodynamic characteristics, and structural integrity. Electrical power for the electronics housed in the pod is supplied by a generator driven by a ram air turbine (RAT). The RAT generator can provide 4 KVA of power even at landing speeds. At cruise airspeeds it can produce 20 KVA. This will be sufficient electrical power to operate a wide variety of avionics systems such as a forward-looking infrared (FLIR) scanner and low light level television to provide passive landing guidance for STOL landing operations.

One of the interesting features of the SAMSON pod is that all the control and data links with the aircraft





Window-mounted infrared data link equipment.



A ram air turbine (RAT) driving a built-in generator supplies the SAMSON pod's electrical power.

are optical, requiring no hard-wired connections when the pod is installed on the aircraft. The infrared data links look through the existing fuselage windows, requiring no airframe modifications for installation. The operator consoles for the SAMSON pod are set on aircraft pallets which can be expeditiously removed or installed in the cargo compartment.

There has been interest expressed by several C-130 operators in the various proposed configurations of the SAMSON pod, and uses such as maritime patrol, border patrol, radio relay, and low-level terrain-following guidance systems.

#### MOBILE DATA CENTER

Included in the HTTB data system is a mobile data center — a van that has a telemetry and television link with the aircraft and can provide on-site real-time processing of data as well as plotting and printing of data in the field. Data processing equipment installed in the van includes a VAX-11/751 computer, complete with printer, plotters, tape recorders and video terminals. The 33-foot long van accommodates four technicians and can be transported in the cargo compartment of the HTTB, giving the HTTB system worldwide test capability. When the HTTB lands at a test site, the van can

be quickly driven off and set up to analyze data relayed by telemetry from the test aircraft.

## WORLDWIDE INTEREST

The HTTPB program has received a great deal of worldwide attention. Its most recent appearance was at the Paris Air Show, where the Federation Aeronautique Internationale presented Lockheed with certificates recognizing the HTTPB's world record-setting performance in short takeoff, time-to-climb, and landing distance. In setting the records, the HTTPB took off in 427 meters (1401 feet). It climbed to 3000 meters (9843 feet) in 3 minutes, 57.4 seconds; to 6000 meters (19,685 feet) in 9 minutes, 0.35 seconds; and to 9000 meters (29,528 feet) in 17 minutes, 41.71 seconds. Gross weight at takeoff was 44,725 kilograms (98,600 pounds). The landing roll was 335 meters (1099 feet) at a gross weight of 43,091 kilograms (94,998 pounds).

The HTTPB was earlier involved in six tours that included visits to various universities around the country and the Society of Flight Test Engineers symposium at St. Louis, Missouri.

In addition to the tours mentioned above, there have been over 80 program briefings to various governmen-

tal agencies, technical societies, and educational institutions. More than 40 newspaper and magazine articles have been published about the HTTPB and its accomplishments.

The HTTPB program has been received with enthusiasm by the aerospace and academic communities. Manufacturers of aerospace vendor parts and systems have responded to the HTTPB program by sharing their expertise and contributing nearly 8 million dollars worth of advanced-technology equipment. This very active response reflects the industry consensus that the HTTPB concept and the unique opportunity to integrate advanced concepts into flight test hardware that it offers represent a significant step forward in aerospace research capability.

## THE SYSTEM

The HTTPB system — the modified aircraft, LADS, and the mobile data center — allow testing options ranging from evaluating a single, small element to a full-scale, highly complex systems test. Interactive flight testing is another exciting possibility with the HTTPB. While in flight, telemetry can be received by a ground station at Lockheed-Georgia. From there it can be distributed to sophisticated computers for advanced pro-



cessing, and at the same time shared with other users. For example, while a test is in progress, onboard TV cameras focused on the flight station crew can be monitored by human factors engineers developing stan-



dards for advanced flight station design. Simultaneously, other test engineers can receive the same data to feed to a flight simulator for a different part of the test.

In addition to Lockheed-Georgia's own technology research programs, the HTTB system is being made available to government agencies, universities, and other companies for technology evaluation in an airborne environment. For further information on the HTTB system, call or write to:

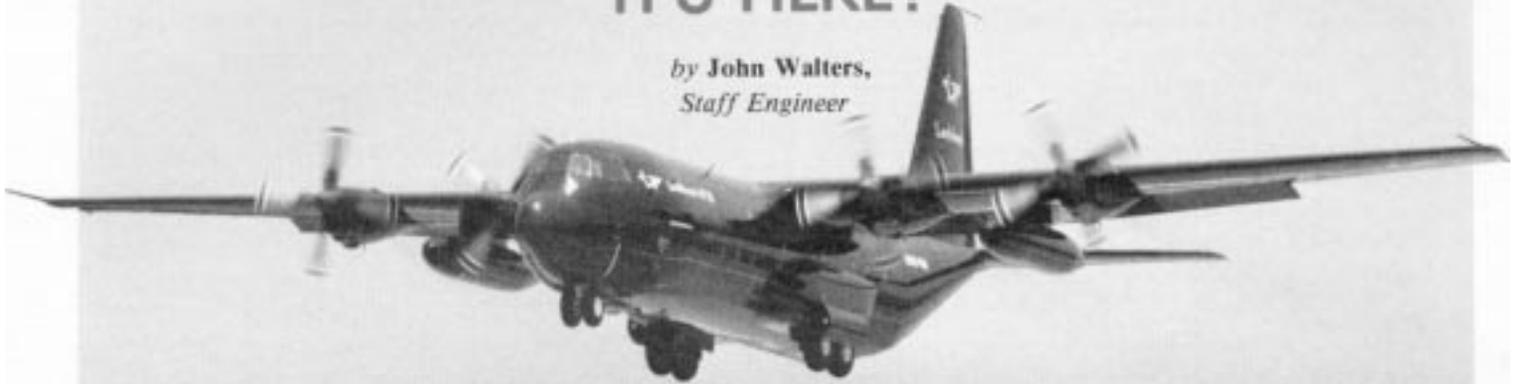
R. H. Sandt, Manager  
Advanced Technology Program Sales  
Dept. 67-12, Zone 22  
Lockheed-Georgia Company  
Marietta, Georgia 30063  
Telephone (404) 424-4914

**SERVICE  
NEWS**



# VERY HIGH PRESSURE HYDRAULICS: IT'S HERE!

by John Walters,  
Staff Engineer



An advance in technology and the vehicle that allows development of that advance have arrived at the same place at the same time. Such is the case with the 8000-psi hydraulic system which will provide power to the new spoilers on the HTTB aircraft.

The use of 8000-psi hydraulics has been under serious development by all major airframe companies since J. N. Demarchi and R. K. Haning of North American Rockwell Corporation authored Technical Report NR 72H-20, "Application of Very High Pressure Hydraulic Systems" in March, 1972. The HTTB offers a unique opportunity to study the operating characteristics of 8000-psi hydraulics in a specially instrumented, functioning aircraft.

The HTTB will have three independent X000-psi hydraulic systems. These systems will be installed in addition to the three 3000-psi hydraulic systems which are presently on the aircraft. One of the new systems will be powered by an 8000-psi engine-driven pump. The two other systems will be powered from two of the existing 3000-psi systems, utilizing power transfer units which will boost the pressures from 3000 psi to 8000 psi. The power transfer units consist of a 3000-psi motor driving an 8000-psi pump. There is no fluid transfer across the system boundaries.

Survivability requirements established for new military aircraft have provided a major stimulus for the development of 8000-psi hydraulic systems. These standards ban use of any flammable hydraulic fluids, which effectively eliminates most of the conventional fluids currently in service.

As part of the effort to solve this problem, a nonflammable fluid is now under development at the Air Force

Wright Aeronautical Laboratories (AFWAL) at Wright-Patterson Air Force Base. The principle component of this fluid is chlorotrifluoroethylene, or CTFE. Several laboratory test programs sponsored by the U. S. military are presently evaluating the use of CTFE in 8000-psi systems and the effect of this medium on pumps, seals, and valves.

The new fluid is nonflammable, but it weighs approximately two and one-half times as much as MIL-H-5606 or MIL-H-83282, the hydraulic fluids now used on the C-130 and many other aircraft. When CTFE fluid is used in conjunction with an 8000-psi system, however, the increase in fluid weight can be compensated for by the increase in pressure load, which allows significant reductions in the amount of fluid required and the size of hydraulic system components. In fact, the use of 8000-psi hydraulics in place of the conventional 3000-psi system on an airplane the size of the Hercules aircraft could decrease the weight and volume of hydraulic system components sufficiently to virtually eliminate any weight penalty imposed by the use of CTFE fluid. The use of the new fluid and 8000-psi pressures can thus provide the advantage of a nonflammable fluid medium without adding to the total weight of future hydraulic systems.

The CTFE fluid currently being formulated by the AFWAL carries the designation A-02. It is based upon Safetol 3.1 oil, manufactured by Halocarbon Products Corporation, 82 Burlews Court, Hackensack, N.J. 07601. Limited quantities of A-02 CTFE fluid are available through the Materials Laboratory at Wright-Patterson AFB, OH 45433.

**SERVICE NEWS**

Adapted from the High Tech Test Bed Newsletter.

## New Lockheed-Designed

# SYNCHROPHASER TEST SETS

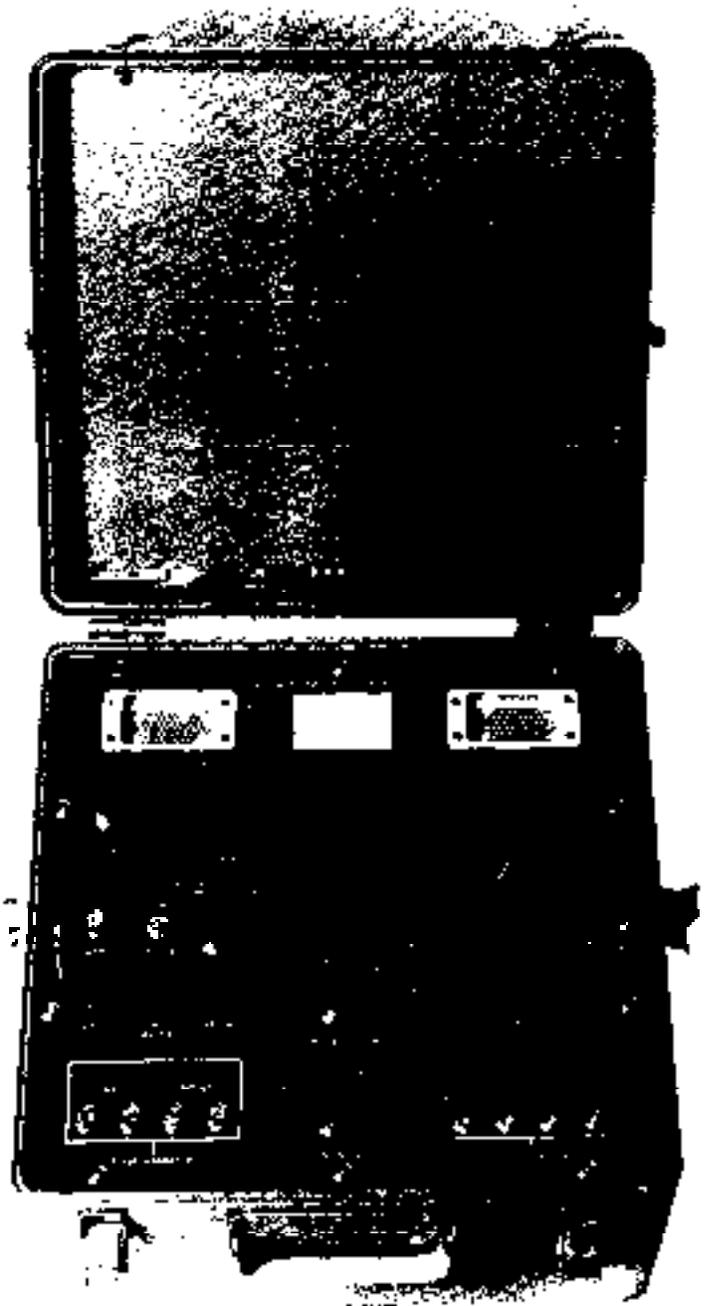
by **Earl Cunningham**, *Electronics Group Engineer*  
**Raymond Yearty**, *Supply Sales Planner Senior*

Servicing the synchrophaser system of the Hercules aircraft is often tedious and time-consuming, especially for an operator having both vacuum tube and solid-state synchrophasers. Recent technological advances, however, have led to the development of new test equipment which simplifies testing procedures, saving both time and money. This article introduces the Lockheed-designed test equipment now available for synchrophaser maintenance.

### Flightline Maintenance

Lockheed has used the latest in digital circuitry technology to produce a new highly compact Synchrophaser System Test Set, P/N 3402801-5 (Figure 1). This test set was designed to combine in one lightweight box all of the equipment necessary for functional testing of both solid-state and tube-type synchrophasers. The 3402801-5 test set takes the guesswork out of servicing the synchrophaser by using digital readouts instead of analog meters. In addition, the reliability of this new unit is enhanced by the use of easily maintainable solid-state circuitry.

The Lockheed test set eliminates the need for additional equipment previously used in performing engine trim and assessment of synchrophaser performance. It provides functional test capability of all synchrophaser system components, go-no-go testing of the propeller pickup, and measures propeller angle. The set includes a switchable solid-state megohmmeter, voltmeter and oscilloscope output, as well as the required interface cables.



*Figure 1.* P/N 3402801-5 Synchrophaser System Test Set.

---

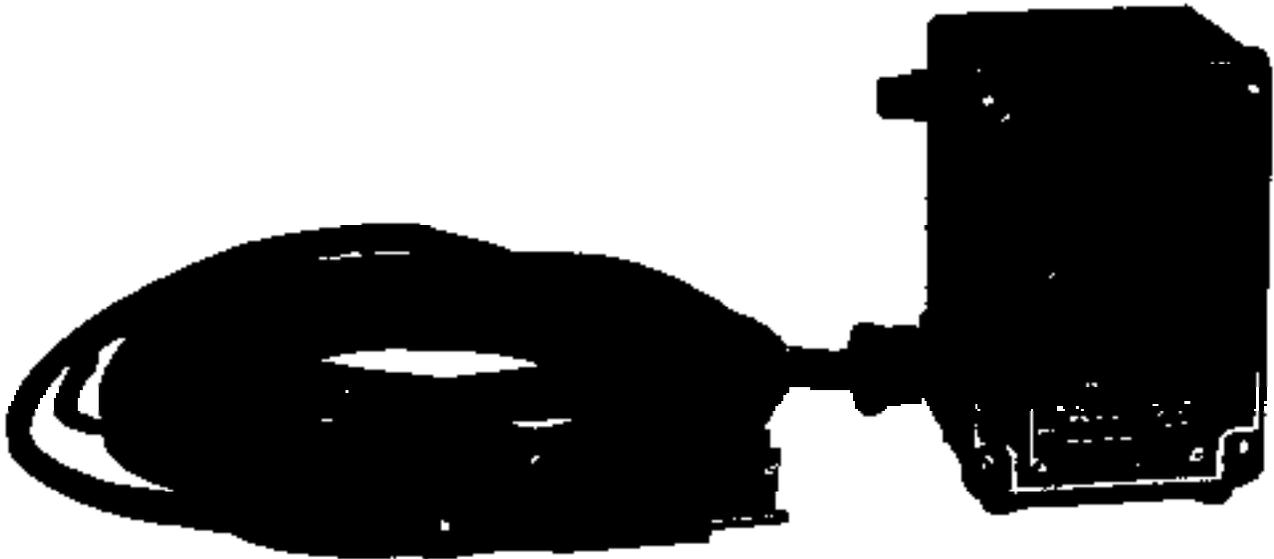
A Master Percent RPM Indicator (Figure 2), part of the Synchrophaser Test Set described below, can be procured separately under P/N 3402875-1. This unit is used to perform engine power trim with a high degree of accuracy in both ground and flight conditions. It weighs 2 pounds and requires calibration only once a year.

### Shop Maintenance

For Hercules aircraft operators wanting greater capability, Lockheed has designed a Synchrophaser Test Set, P/N 3402801-7 (Figure 3), that can be used for shop repair of both types of synchrophasers. This test set has several unique features designed to virtually eliminate operator error. First, the circuitry used to generate phase angles is entirely digital. This enhances accuracy and eliminates routine calibration checks. Also, when phase angles are changed during the testing procedure, this test set provides a unique method of preventing latch-up of

the overspeed and underspeed circuits in the synchrophaser. This shortens and simplifies the test procedure because the knobs and switches traditionally used to set up test conditions are largely eliminated. All such variables are stored in an EPROM (Erasable Programmable Read Only Memory) installed in the test set. When the operator has completed meter readings for one test step, he simply depresses two push buttons on the test set panel and is then ready to take meter readings for the next procedure. All test conditions are automatically established by the EPROM.

Extender cards are provided with each test set to enable troubleshooting and adjusting of detailed system components. A complete test of either type of synchrophaser can be performed by a relatively inexperienced technician in approximately 60 minutes. This test set also includes the capability of testing the solid-state synchrophaser 2 1/2% RPM limit circuit.



*Figure 2. P/N 3402875-1 Master Percent RPM Indicator.*

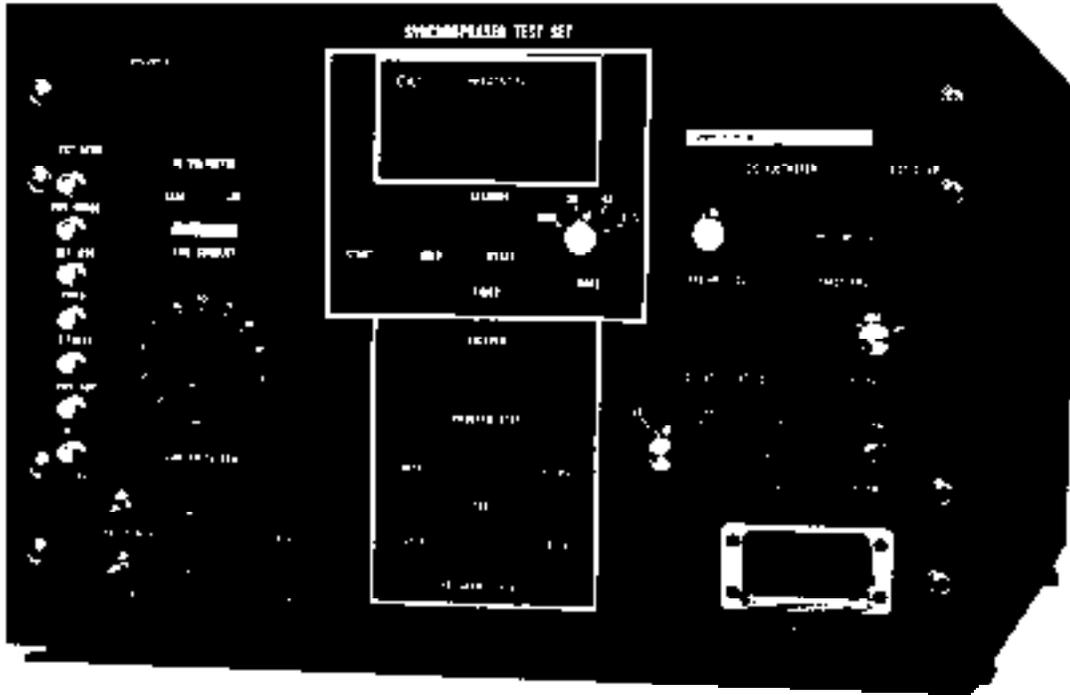


Figure 3. P/N 3402801-7 Synchrophaser Test Set.

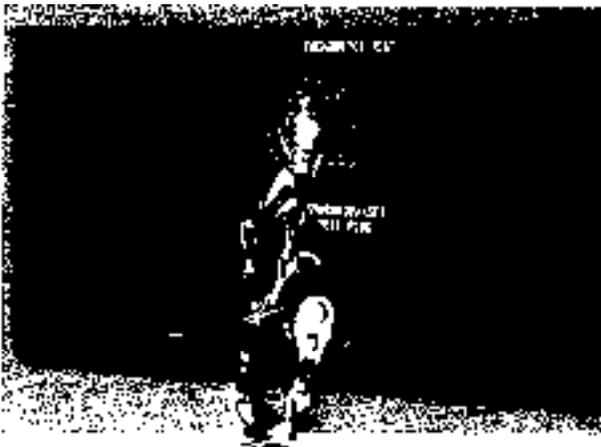


Figure 4. Iron lung panel, tachometer test and synchrophaser test plug.

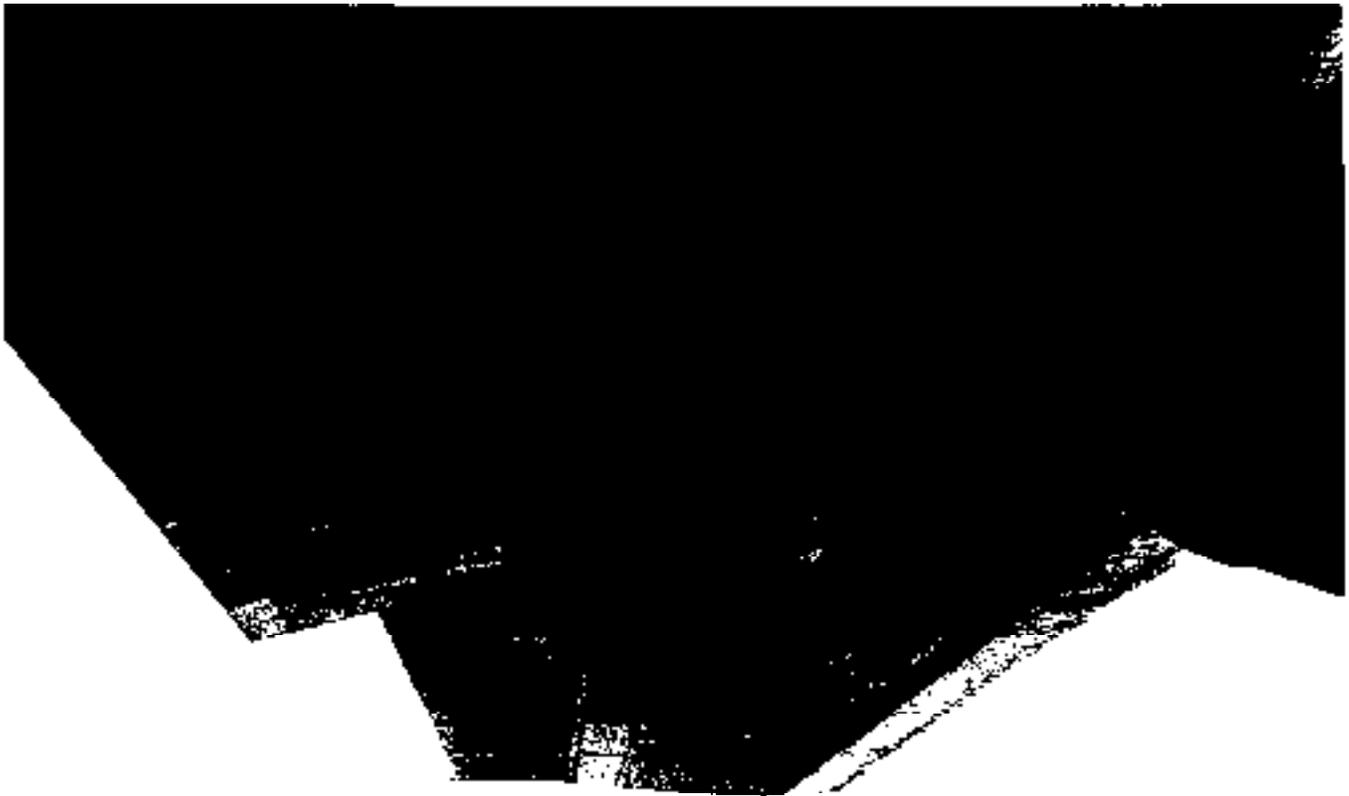
The new synchrophaser system test sets were designed to make testing and repair of the synchrophaser more efficient. Through ease of operation and improved accuracy, these Lockheed-designed test sets should prove a great advantage to Hercules aircraft operators.

If you would like additional technical or procurement information about the -5 and -7 synchrophaser test sets, please direct your inquiries to the Manager, Supply Sales and Contract Department, at the following address:

Lockheed-Georgia Company  
 Supply Sales and Contracts Department  
 Dept. 65-11, Zone 451  
 Marietta, Georgia 30063  
 Telephone (404) 424-4214  
 TELEX 804263 LOC CUST SUPPL

**SERVICE NEWS**

# HERCULES FLAP SYSTEM



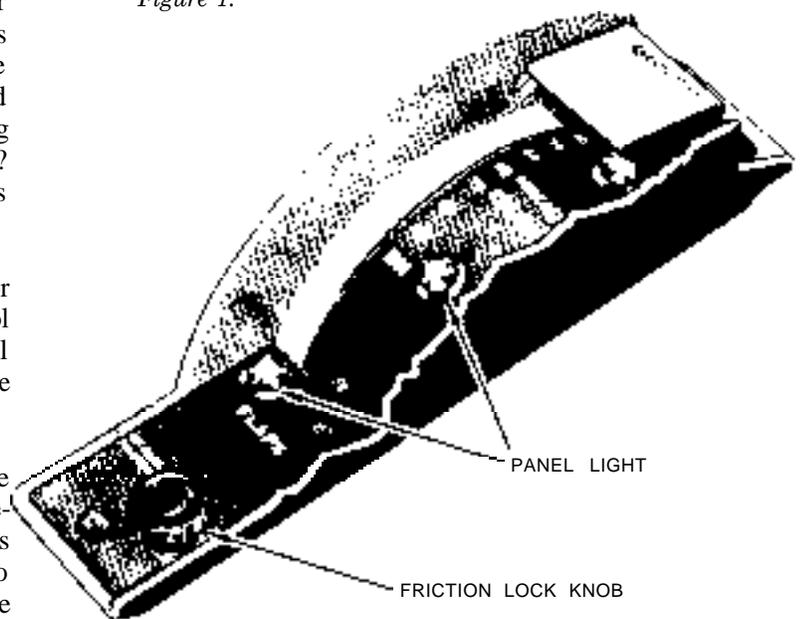
Our capacity for taking things for granted is sometimes amazing. We assume our car will start the next time we turn the key, that our ball-point pen will write every time. And that's as it should be. We should also have the right to assume all the systems in our airplane will function properly. For instance; as long as utility hydraulic pressure and DC electrical power are available, the flaps on the Hercules aircraft should operate - and usually do. But suppose we are lacking one or the other - or both - ingredients. What then? Sure, we all know how the flap system works, but let's refresh our memory.

The major components of the system are the selector lever in the flight deck (Figure 1), the flap drive control and motor (Figure 2), the flap brake, the flap control (selector) valve, the emergency flap brake valve, and the asymmetry sensing switches and brakes (Figure 4).

The four (two per wing) Fowler-type wing flaps are manually controlled and hydraulically actuated. Movement of the control lever in the flight deck quadrant is transferred through the interconnecting cable system to the flap drive control unit. Switches in the flap drive follow-up unit are actuated, completing the circuit to either the up or down solenoid of the flap selector valve as selected (Figures 5 and 6). Utility system hydraulic pressure is directed by the flap selector valve to drive the flaps in the desired direction. This fluid passes

through the emergency flap brake valve to the flap selector valve.

Figure 1.



FLAP QUADRANT PANEL

The normal (deenergized) position of the emergency flap brake valve diverts utility system hydraulic pressure to the flap selector valve and connects the hydraulic line for the asymmetry brakes to the utility system return line. More about these brakes later.

The first action of the hydraulic pressure is to release the spring-actuated flap brake mounted on the flap drive gear box. With the brake released, the hydraulic motor is driven in the direction called for by the selector handle. When the flaps reach the selected position, follow-up switches in the flap drive unit are actuated, deenergizing the flap selector valve and removing pressure from the drive motor and brake. Flap movement stops and the spring-loaded brake engages to hold the flaps in position.

Flap operation is basically the same in either direction - the reversible hydraulic motor drives either up or down as selected. Flow regulators and restrictors maintain a uniform pressure drop through the motor, preventing overspeeding or cavitation due to air loads being imposed while the flaps are retracting.

During normal operation of the flaps, the asymmetry brakes, located at the extreme outboard ends of the torque shafts, are spring-loaded off to the release position.

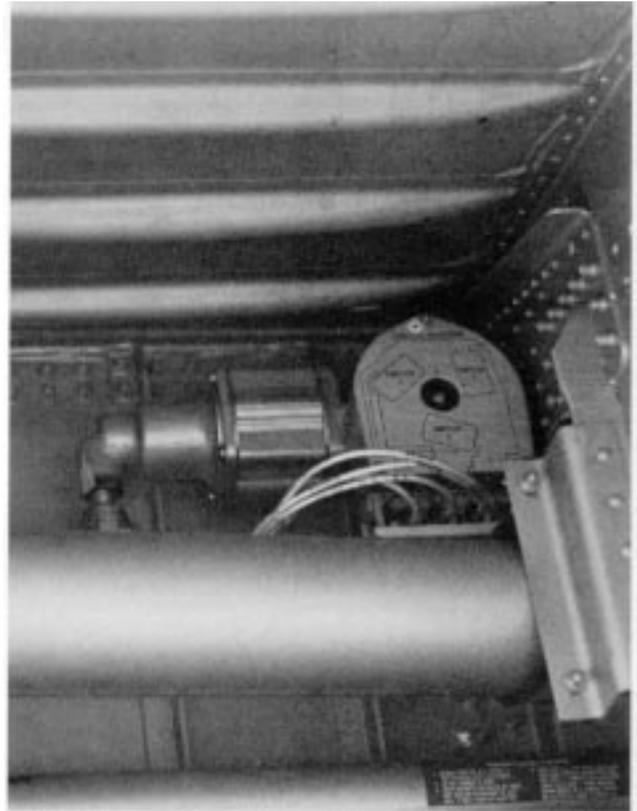
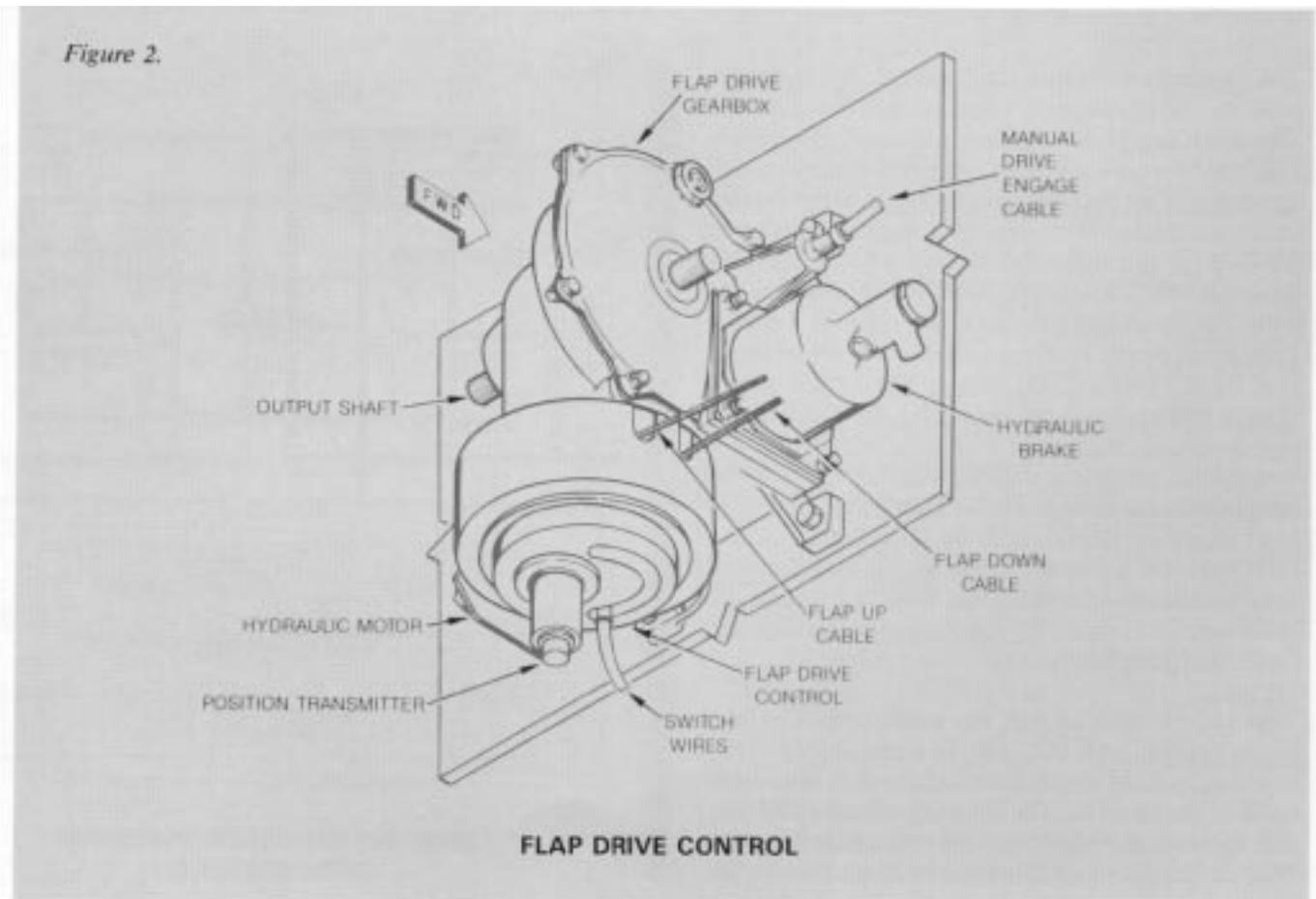
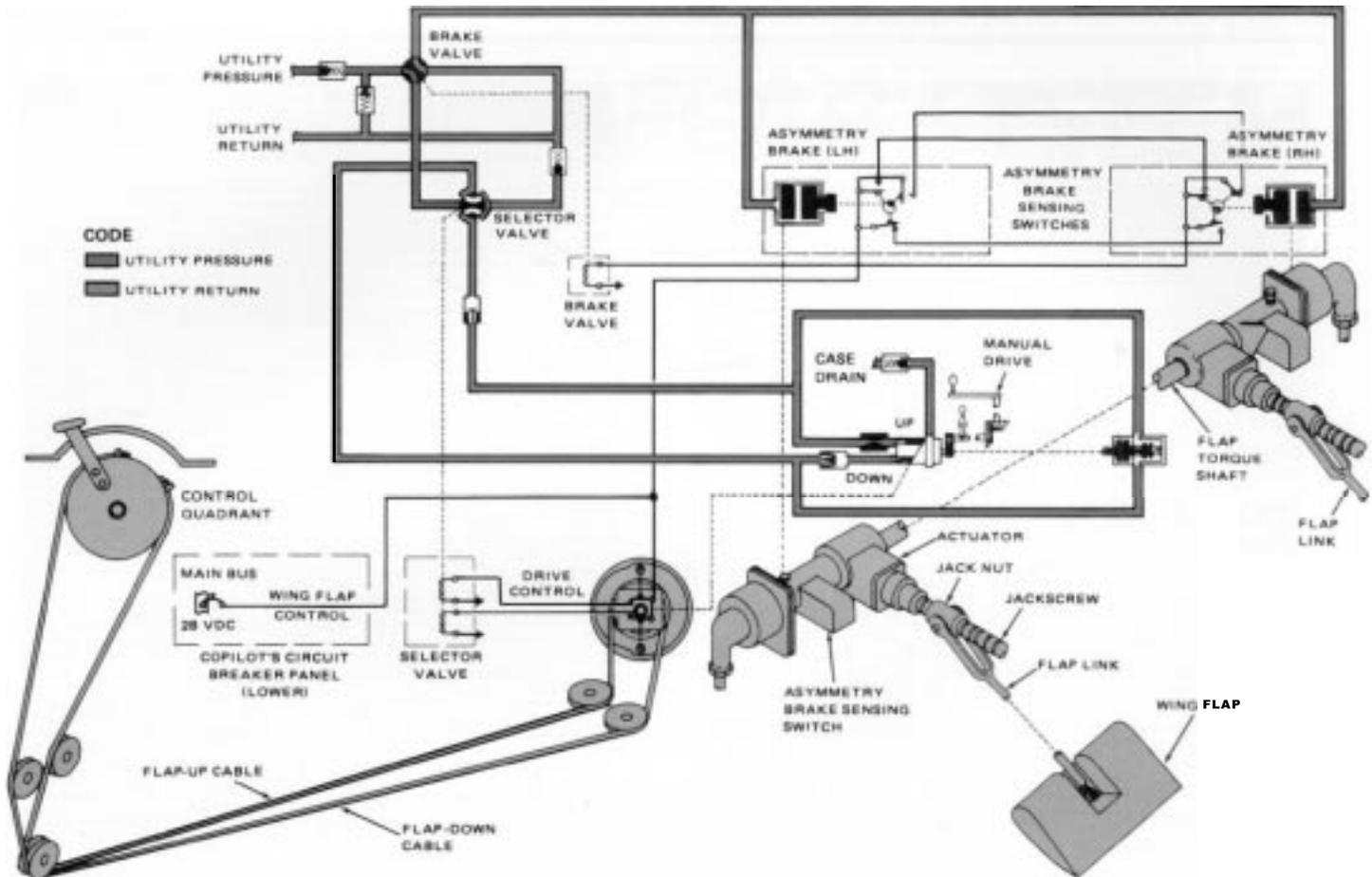


Figure 3. Flap asymmetry sensing assembly.



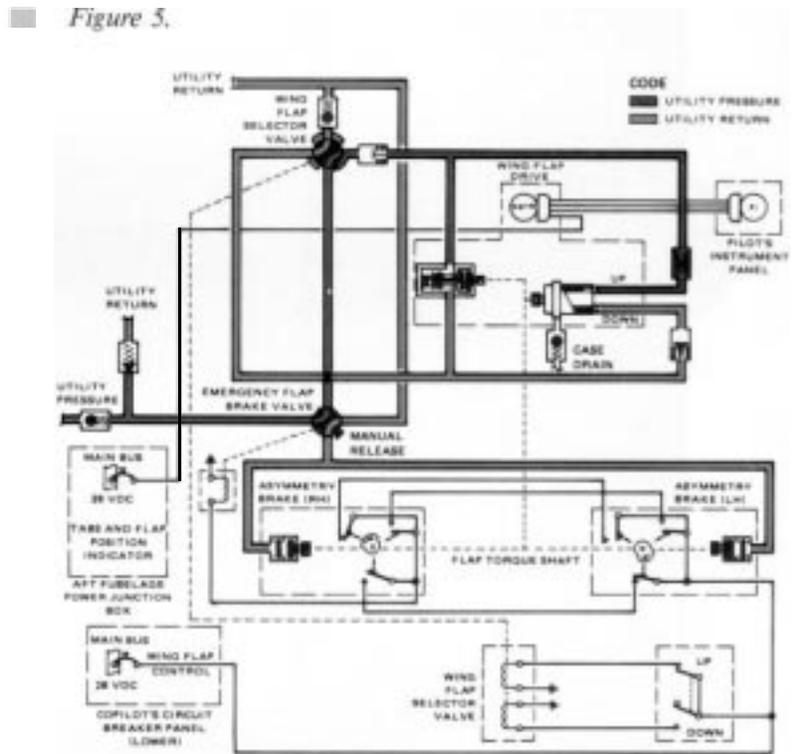


**WING FLAPS SYSTEM SCHEMATIC**

Figure 4.

The asymmetry brakes are applied by hydraulic pressure. In the normal (deenergized) position, the emergency flap brake valve keeps the brakes' hydraulic line open to return. Mounted along with the brakes and driven by the torque shafts are the asymmetry sensing assemblies (Figure 3), consisting of three switches each. As long as the torque shafts are moving together (synchronized), the sensing switches can't complete the circuit to the emergency flap brake valve. If a torque shaft should break or otherwise get out of synchronization, further rotation will cause a pair of switches to close at the same instant, completing the circuit to the emergency flap brake valve (Figure 7). When this valve is energized, pressure is diverted from the flap selector valve to the asymmetry brakes, stopping flap movement and locking the flaps in position. The emergency flap brake valve has a manual release for resetting the valve once the solenoid is deenergized. Note that this should be accomplished only on the ground to prevent a worse "split-flap" condition.

As with any other system, our troubles can start with minor malfunctions that may be compounded by inadvertent or hasty action. Let's say we select flaps down and nothing happens. The hydraulic system looks normal, so we assume that the problem must be electrical. Then we go to the flap selector valve located on the left



**WING FLAPS SYSTEM SCHEMATIC  
UP OPERATION**

side of the cargo compartment forward of the left wheel well and actuate the manual override button to the DOWN position. It is spring-loaded off and must be held in until the desired flap position is reached. The flaps start moving down, and suddenly the pilot calls “split flaps!” as the airplane rolls. Imagine performing this operation during a maneuver such as a turn onto final approach on a turbulent day. Things could get out of hand in a hurry.

But, you say, the asymmetry sensing switches would immediately sense the out-of-sync operation of the flaps and lock them in place. Look at the electrical schematic again. The asymmetry sensing switches are powered through the same circuit breaker as the control system. Trouble in the control circuit could very well render the asymmetry circuit inoperative. So, if you aren’t sure where the trouble lies, actuate the manual override of the flap selector valve in small increments and verify synchronized flap movement before going past the point of no return.

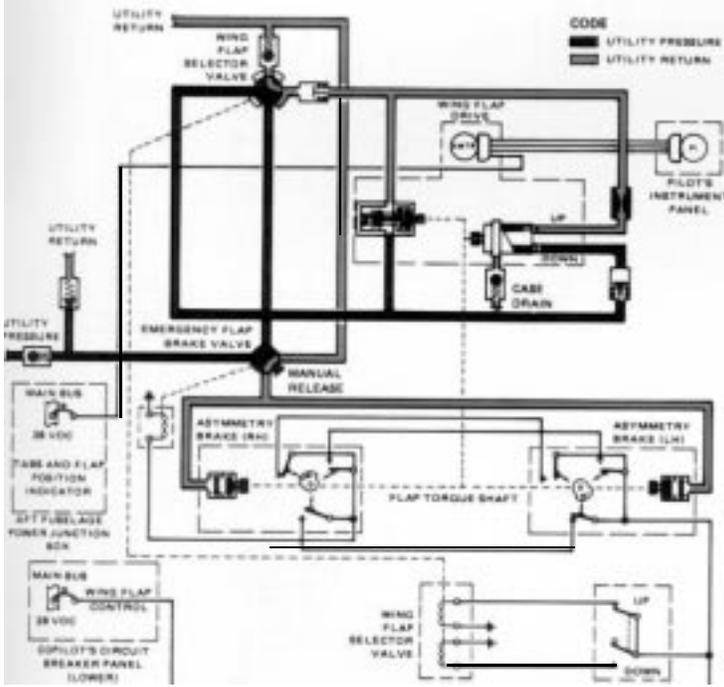
Note that if the emergency flap brake valve has already been energized by the asymmetry sensing circuit, it must not be reset until the aircraft is on the ground. The “split-flaps” condition could drive beyond the point of aircraft control.

When hydraulic pressure is not available, the flaps can be cranked down by hand (or up, for that matter). Just follow the placarded directions. Again, check for synchronized flap movement - remember, hydraulic pressure and electrical power are required to set the asymmetry brakes.

The flap position indicator is powered through a separate circuit breaker; it will function even during manual operation. It indicates the position of the flap drive control assembly, but it will not indicate a “split-flaps” condition.

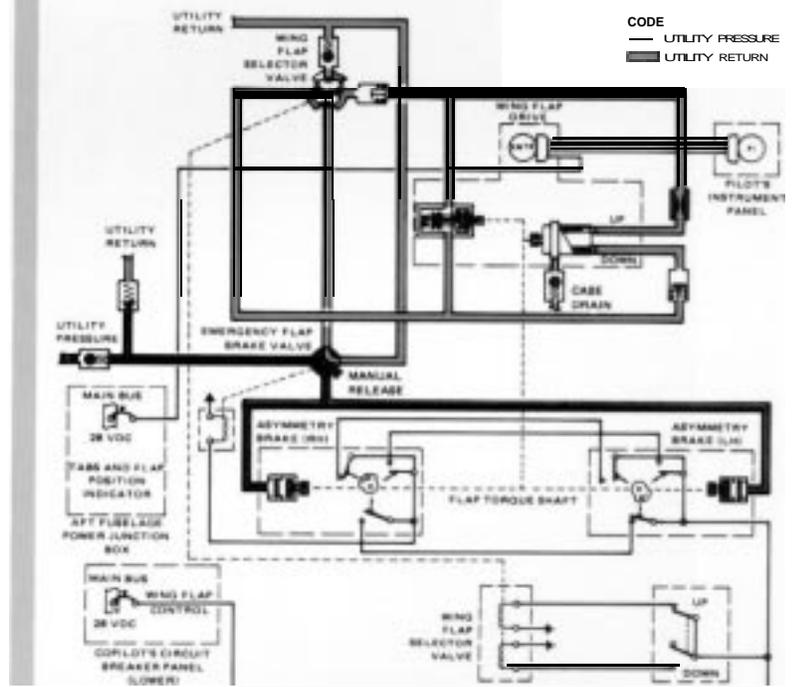


Figure 6.



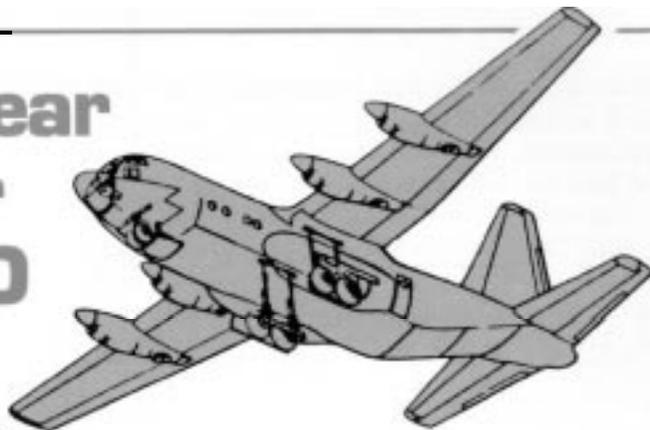
**WING FLAPS SYSTEM SCHEMATIC  
DOWN OPERATION**

Figure 7.



**WING FLAPS SYSTEM SCHEMATIC  
ASYMMETRY BRAKES ON**

# Main Landing Gear Friction Washer SPLASH GUARD



New production Hercules aircraft now incorporate an improvement that reduces the possibility of partial main landing gear retraction during operation in cold climates. The problem results from ice build-up on the friction washers, rendering them temporarily ineffective in the performance of their function.

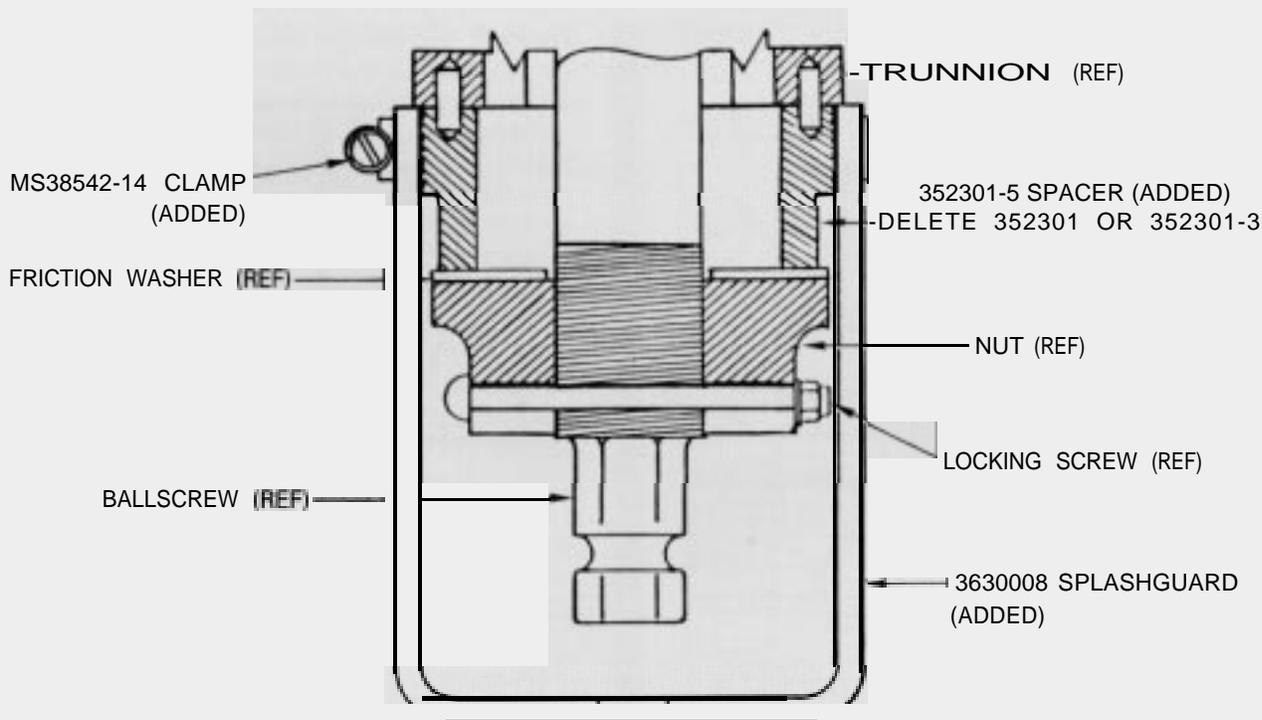
The improvement is a splash guard which will shield the friction washer area from ice, slush, and other contaminants. The splash guard will also benefit operators in dry, dusty conditions.

The splash guard was developed several years ago for the Canadian Air Force because of problems they had

encountered with partial retractions, as well as contamination of the friction washer area with dry debris. Since then, other operators have modified their aircraft to include the splash guards and have found them to be cost-effective and reliable.

The modification is not very difficult to accomplish, but does require jacking the aircraft, using wing and fuselage jack points. This is necessary in order to replace the P/N 352301 or P/N 352301-3 spacer with a thicker P/N 352301-5 spacer. Once this is accomplished, it is

Figure I.



MAIN LANDING GEAR SPLASH GUARD INSTALLATION (CROSS SECTION).



Figure 2. Main landing gear splash guard installed.

a simple matter to clamp the splash guard in place over the main landing gear ball screw (see Figure 1). Specific instructions for performing this improvement as well as ordering details, weight and balance information, and manpower requirements may be found in Hercules Service Bulletin #82-470 or Commercial Hercules Service Bulletin #382-32-34.

## *SERVICE NEWS*





 *Lockheed-Georgia Company*

CUSTOMER SERVICE  
LOCKHEED-GEORGIA COMPANY  
A Division of Lockheed Corporation  
Marietta, Georgia 30063