

 Lockheed

VOL. 18, NO. 4 OCTOBER-DECEMBER 1991

SERVICE NEWS

A Service Publication of Lockheed Aeronautical Systems Company



Understanding Thermocouples
Index

Lockheed SERVICE NEWS

A SERVICE PUBLICATION OF
LOCKHEED AERONAUTICAL
SYSTEMS COMPANY

Editor

Charles I. Gale

Art Director

Anne G. Anderson

Vol. 18, No. 4, October-December 1991

CONTENTS

- 2 Focal Point
W. D. Abbsille,
Regional Mgr. - Western Europe
International Sales
- 3 Understanding Thermocouples
The most critical parts of the
engine's temperature control
system, thermocouples deserve
your undivided attention.
- 11 Cumulative Index 1974-1991
A complete, alphabetical listing of
Service News technical articles.

Photographic Support: John Rossino

Cover: In a special flyby celebrating 25 years of service with the United Kingdom, the RAF's Silver Jubilee C-130K returns "home," passing over the LASC manufacturing facility in Marietta, Georgia, where it was built. The aircraft's fuselage is decorated with the emblems of all the British squadrons that have flown the C-130. The back panel shows a closeup of the proud "25" emblazoned on the aircraft's tall vertical stabilizer.

Service News is published by Lockheed Aeronautical Systems Company, a unit of Lockheed Corporation. Information contained in this issue is considered by Lockheed to be accurate and authoritative; it should not be assumed, however, that this material has received approval from any governmental agency or military service unless it is specifically noted. This publication is for planning and information purposes only, and it is not to be construed as authority for making changes on aircraft or equipment, or as superseding any established operational or maintenance procedures or policies. The following marks are registered and owned by Lockheed Corporation: "Lockheed," "Hercules," and "JetStar." Written permission must be obtained from Lockheed Aeronautical Systems Company before republishing any material in this periodical. Address all communications to Editor, Service News, Department 66-14, Zone 0088, Lockheed Aeronautical Systems Company, Marietta, Georgia 30063. Copyright 1991 Lockheed Corporation.

Focal Point



Bill Abballe

25 Years of Achievement

The Royal Air Force will be celebrating 1992 as the silver anniversary year of its Hercules aircraft operation. We proudly salute the RAF for the outstanding performance of its C-130 program, and we extend special recognition to the air and ground crews throughout the United Kingdom whose superb contribution over the years has made this success possible.

In the closing weeks of 1991, LASC had the distinct privilege of honoring these dedicated professionals by participating in the kickoff of the anniversary celebration. A delegation from Lyneham Air Base in England brought one of their prized C-130 aircraft to Lockheed's Marietta production facility for a re-enactment of the first delivery to the RAF in December of 1966. The particular RAF Hercules used for this flight is rather special. Designated as the "Silver Jubilee" C-130, and shown on the cover of this issue of Service News, the aircraft has a distinctive and innovative paint scheme that leaves no doubt as to the pride the RAF has in its Hercules fleet.

The people who have operated and serviced this outstanding fleet over the past 25 years have every right to be proud of their special history. A total of 66 C-130 aircraft were delivered to the RAF, and they have been used with exceptional skill and professionalism. From early on, the RAF used its famed aeronautical expertise to advance the capabilities of the Hercules design. The RAF pioneered increasing the cargo capacity of the C-130 by lengthening its fuselage, and also provided unlimited range for the Hercules by outfitting it for aerial refueling.

These innovations contributed to the success that allowed an almost 25-year-old fleet to operate at nearly double its normal task role in support of Desert Storm. The same kind of performance has been achieved in humanitarian efforts as well. When the RAF was called upon to drop relief supplies to Kurdish refugees on the Turkish-Iraqi border, they had only to call on the experience gained in earlier missions. As early as 1967, the RAF successfully met the challenge of a massive airlift out of Aden. The challenge was repeated in 1973 with famine relief missions in mountainous areas of Nepal, and many times since then.

The crews who fly and support those missions and the RAF team members who visited Marietta affectionately call the versatile Hercules "Fat Albert." They believe Albert will go anywhere and do whatever is needed. They ought to know: they've been there and they've done it. We tip our hat to everyone involved in the RAF C-130 program and wish them another 25 years of continuing achievement.

Sincerely,

Regional Manager - Western Europe
International Sales

PRODUCT SUPPORT

LOCKHEED AERONAUTICAL
SYSTEMS COMPANY

H. L. BURNETTE DIRECTOR

FIELD
SUPPORT

SUPPLY
SUPPORT

TECHNICAL
PUBLICATIONS

FMBS
DESIGN

CUSTOMER
TRAINING

J. D. Adams

J. L. Bailey

A. G. Hunt

H. D. Hall

S. S. Clark

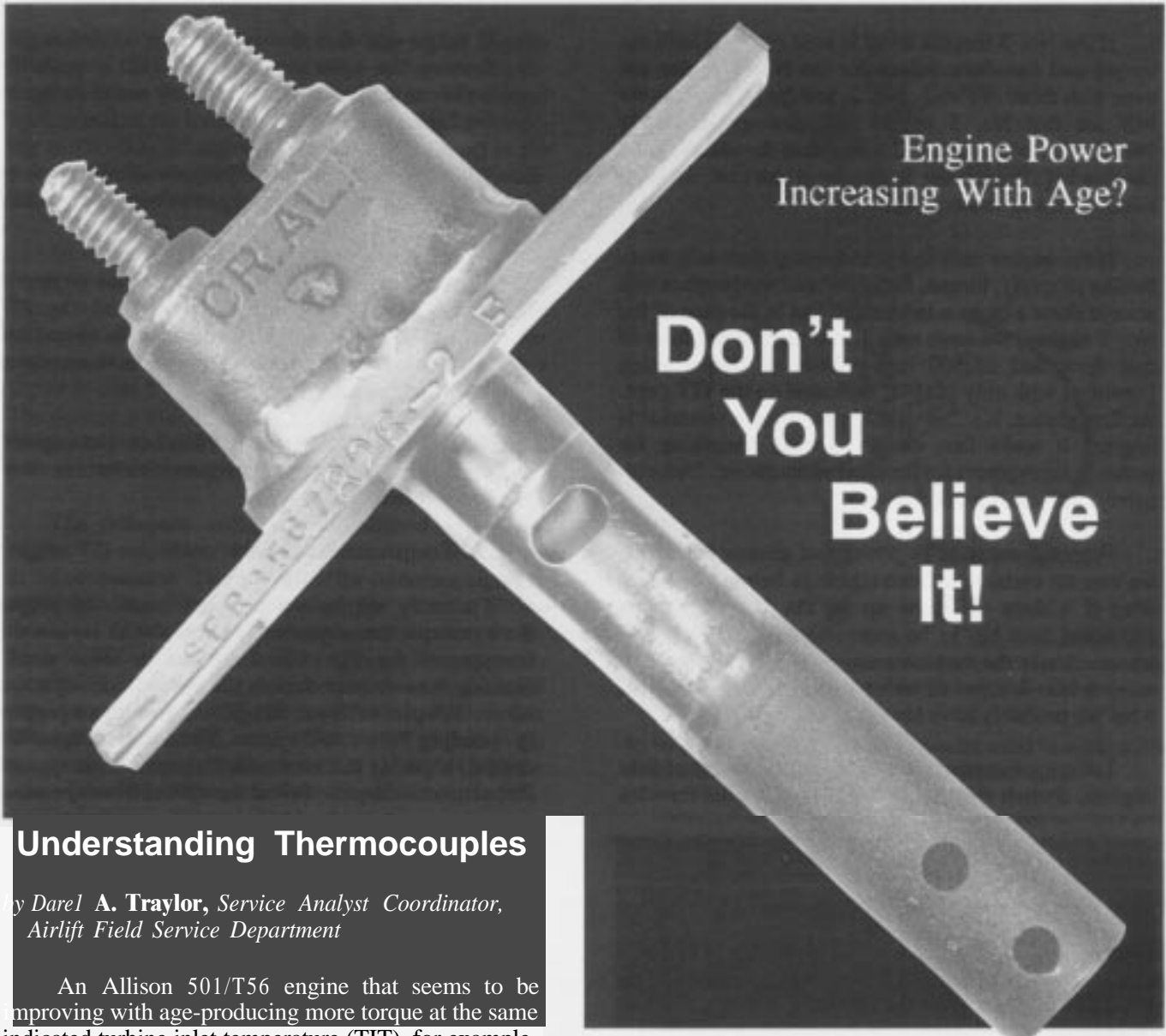

Understanding Thermocouples

by Darel A. Traylor, Service Analyst Coordinator,
Airlift Field Service Department

An Allison 501/T56 engine that seems to be improving with age—producing more torque at the same indicated turbine inlet temperature (TIT), for example—should immediately attract your attention. Some things are just too good to be true, and this is one of them. There is a strong possibility of trouble in the TIT indicating system of this engine and prompt action is needed to prevent overtemperature damage.

One common problem that can cause just exactly these symptoms is bad thermocouples. When one or more of these TIT pickup units fail, incorrect TIT readings will be displayed in the flight station and incorrect temperature inputs will be received by the temperature datum (TD) control system. Worse still, the turbine may be exposed to excessive temperatures as a result.

A Case Study

You don't have to be an expert with 20 years of experience to troubleshoot potential overtemperature problems in 501/T56 engines successfully. In fact, all

that is really required is to be in the flight station with four engines running and the engine instrument panel in front of you.

Let us use the following set of engine readings as an example:

Engine No.	1	2	3	4
Torque (in-lbs)	15,000	15,000	16,500	15,000
TIT (°C)	1,010	1,010	1,010	1,010
Fuel Flow (lbs/hr)	1,100	1,100	1,300	1,100

Something unusual is going on here. With the TD control system selected to AUTO, the above readings show that No. 3 engine is using more fuel and developing more torque than any of the other three engines. The fuel flow is also greater than is normally required for the engine to reach 1010°C.

If the No. 3 throttle lever is now retarded until the torque and fuel flow values for the No. 3 engine are even with those of No. 1, No. 2, and No. 4 engines, we will see that No. 3 engine indicates approximately 988°C TIT, which is 22°C lower than the others. How can this be? The answer is simple: it can't be. There is missing heat in this equation.

If the engine instrument indicating system is functioning properly, torque, fuel flow, and temperature will always show a close relationship. But in the case of the No. 3 engine, we have seen 1,300 pounds per hour of fuel flow and 16,500 inch-pounds of torque being generated with only 1010°C indicated on the TIT gage. At first glance, No. 3 would appear to be a remarkable engine. It looks like we are getting something for nothing; more power for the same temperature. Unfortunately, it doesn't work that way.

Where there is more power and greater fuel flow, we can be certain that extra heat is being generated, even if it does not show up on the TIT gage. This additional heat has to be somewhere, and it is somewhere. It's in the turbine area, reducing this engine's service life. Instead of an exceptionally good engine, what we probably have here is a sick engine.

Let's try something else with this same set of four engines. Switch them all to NULL and set the throttles to 1,000 pounds per hour fuel flow.

Engine No.	1	2	3	4
Torque (in-lbs)	10,000	10,000	10,000	10,000
TIT (°C)	900	900	856	900
Fuel Flow (lbs/hr)	1,000	1,000	1,000	1,000

This set of figures gives us further information about the nature of our problem. No. 3 engine is generating heat that its TIT monitoring system does not know about. By far the most likely cause of this condition is the failure of some of the engine thermocouples to perform their jobs properly. Turbine damage and reduced service life will surely result if this situation is allowed to continue.

Note that with all the engines set to NULL, the throttles may not be perfectly aligned because of differences in the individual fuel controls, and the engine readings will not always line up as neatly as in our examples. But the point is clear: thanks to malfunctioning thermocouples, this aircraft's engine temperature control system is not operating as it should.

Here are some operational guidelines that can be drawn from these examples:

1. If torque and fuel flow are higher on one engine than on the other engines, the TIT is probably higher as well, even though it may not show up on the flight station TIT gage.
2. With all engines in AUTO, the throttle levers should be approximately aligned when the same TIT is indicated.
3. If torque and fuel flow are high on one engine in AUTO with the throttles aligned, and the TIT indications are equal, it is best to use the torque and fuel flow readings of the other engines to set power on the high-reading engine.
4. When you see differences like this between engines, *write it up*. This may prevent serious turbine damage at a later date.

Engine Temperature Control

To really appreciate the significance of proper thermocouple maintenance, it is helpful to review the function of the TD control system in more detail. Nothing is more important to the overall operation and service life of the Allison 501/T56 engine than a properly operating TD control system. The thermocouples are critical, arguably the most critical, parts of this system. Failed thermocouples prevent the system from operating properly, which can lead to increased operating temperatures and greatly shorten engine life.

Here is the reason why. Fuel flow in a 501/T56 power plant is regulated by an electronically controlled

Figure 1. This thermocouple is typical of the air-cooled design used in the T56-A-15 and other series-111 engines.

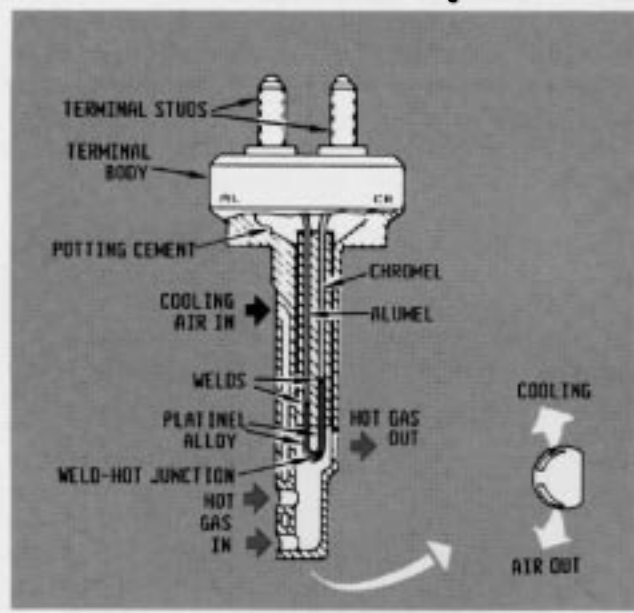

turbine inlet temperature schedule above the throttle crossover. Crossover occurs at 65(± 2)degrees coordinator position. This is the point at which the TD control system makes the transition from the temperature-limiting mode (0 to 65 degrees coordinator position) to the temperature-controlling mode (66 to 90 degrees coordinator position) for temperature-scheduling operation.

In order for the TD control system to operate properly in the temperature-controlling range, two things are required. The first is that a temperature reference signal has to be established (scheduled) for each position of the coordinator above crossover. This signal is used by the TD amplifier as a reference base. The second is that the actual TIT must be measured and transmitted to the TD control system for comparison with the reference signal.

The reference voltage is established within the engine TD amplifier, using input from a potentiometer in the coordinator. The voltage of the reference signal is dependent upon the position of the throttle above crossover. The scheduled reference temperature for T-56-A-9, T56-A-7, and 501-D22 engines is from approximately 760°C to 971 °C, and increases linearly from the crossover point to 90 degrees coordinator position. For T56-A-15, T56-A-16, and T56-A-423 engines, the temperature range is from about 820 to 1077°C. In the case of the 501-D22A, it is 810°C to 1071 °C.

Once the appropriate reference signal has been established, a comparison signal that reflects the actual TIT must be generated. This task is performed by the 18 thermocouples installed around the outside of the turbine inlet case. During engine operation, the TD amplifier compares the signal sent by the thermocouples with the reference signal and then commands any necessary changes in fuel flow to ensure that the engine reaches the TIT scheduled by the throttle position.

The thermocouples are thermoelectric devices consisting of two dissimilar metals which generate specific voltages between points of contact over a given temperature range. The dissimilar metals used in the thermocouples installed in 501/T56 engines are wires made of two different heat-resistant platinum alloys. The wires are joined together at one end to form a junction (Figure 1), with the free ends welded to alumel and chromel wires. These are then connected to a flight station TIT indicator or a TD amplifier, completing the circuit.

For installation in the engine, the platinum junction is enclosed in a heat-resistant probe body and positioned in such a way that it is exposed to the stream of hot gas that passes through the turbine inlet. The difference in temperature between the sensing element-the thermocouple junction-and the component that serves as a junction at the other end of the circuit causes a voltage

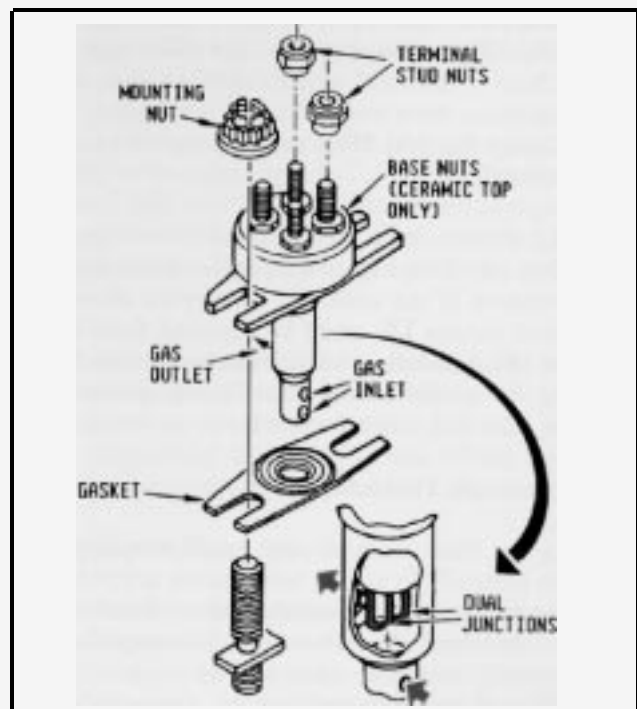

Figure 2. Both thermocouple types have two separate sensing elements. This unit is of the older, non-air-cooled kind.

to be generated. This voltage can be used to accurately determine the temperature at the turbine inlet.

The 18 thermocouple assemblies used in 501/T56 engines each have two separate sensing elements (Figure 2); in all, 36 junctions are therefore involved. One element of each of the 18 units is connected in parallel to provide an averaged signal to the TD amplifier. The TD amplifier uses this signal to determine the actual TIT of the engine. The other element is also connected in parallel. It provides the averaged signal representing TIT that is shown on the flight station TIT indicator.

The reason that the 501/T56 family of engines uses a system of multiple thermocouples connected in parallel is to provide an accurate, overall temperature reading. Because of the gas flow velocities involved and the short distance between the fuel nozzles and the turbine inlet, the combustion gases may mix incompletely. This causes temperature variations at the turbine inlet.

The temperature averaging function of the thermocouple circuit has the purpose of sampling a number of these hotter and cooler areas. It is then able to supply a valid average temperature signal to the TD amplifier and flight station TIT indicator.

Thermocouple Types

Two basic types of thermocouples are used in 501/T56 engines, one which is air-cooled, shown in Figure 1, and one that has no special provision for cooling, shown in Figure 2. The newer, air-cooled type

is used in T-56-A-15, T56-A-16, 501-D22A, and similar series-III Allison power plants. The older type is used with T56-A-9, T56-A-7, and 501-D22 engines. The two configurations have some physical similarities but are functionally distinct. They should never be intermixed in any installation.

Air-cooled thermocouples were developed after experience with the higher temperatures encountered in the operation of the series III turboprops showed that increased service life could be expected from thermocouples designed to take advantage of the flow of cooling air available along the inside surface of the turbine inlet case in these engines.

Thermocouple Problems

As in other sophisticated control systems, the various parts of the engine temperature control system are sometimes subject to mechanical or electrical problems. Fuel controls, TD valves, TD amplifiers, and even wiring harnesses occasionally require troubleshooting and repair or replacement. Fortunately, these components usually produce distinctive symptoms when they fail, which simplifies the troubleshooting process.

Thermocouple trouble is different. Degradation of the thermocouple system often starts out almost imperceptibly and progresses in insidious steps that are easily overlooked. By the time the problem is noticed, an engine may already be damaged. Worse still, an engine that has been exposed long enough to the severe overheating that can result from neglected thermocouples may be subject to sudden failure.

The basic problem, as we have noted, is too much heat. Where one or more of the thermocouples around the turbine inlet are damaged or inoperative, the temperature signals being received by the TD amplifier and the TIT indicator will no longer represent the true TIT values. The reason has to do with the design characteristics of the TIT indicator and the TD amplifier.

These devices respond to variations in the minute voltages generated by the thermocouples as the TIT rises and falls during changes in engine power. But the voltages will reflect the actual temperatures involved only as long as normal operating conditions prevail in the TD control system. The electrical resistance loads in the system circuitry are designed to yield accurate results with 18 fully functional thermocouples. The loss of any of the thermocouples will be accompanied by a reduction in current flow that affects the voltage values from which the temperature data are derived.

As a practical matter, this means that if the current flow is reduced by the failure of one or more thermocouples in the circuit, the voltage "seen" by the TIT indicator and the TD amplifier will also be reduced.

Since lower voltage will be interpreted by the engine temperature control system as lower TIT, this sets the stage for overtemperature problems.

Eroded or defective thermocouples that are still producing current can also cause temperature control errors, although for a different reason. In fact, the temperature error in these cases can be even more severe than when a thermocouple has dropped completely off line. In the following paragraphs we will see in more detail the various ways in which thermocouple damage can produce the incorrect TIT signals that cause overtemperature problems.

Open Junctions

The most common types of thermocouple damage that lead to overtemperature conditions in 501/T56 engines are open junctions in air-cooled and non-air-cooled thermocouples, seriously eroded probe tip aft walls in air-cooled thermocouples, and missing probe tips in non-air-cooled thermocouples. Let us first look at what can happen when one or more thermocouples have open circuits.

When a thermocouple develops an open circuit, it generally occurs adjacent to the weld point of the two platinel alloys in the sensing element (Figure 1). For the purposes of the following discussion, we will assume that this has occurred and that both circuits in a thermocouple have failed simultaneously.

A thermocouple that has open junctions completely vanishes from the engine as far as the TD control system is concerned. When such a failure occurs, the loss of current flow from the missing thermocouple has the immediate effect of decreasing the voltage sensed by both the TIT indicator and the TD amplifier. This causes the average temperature signal sent to the TD amplifier and the TIT indicator to decrease.

The reduced temperature signal to the TD amplifier no longer satisfies the reference signal, so more fuel is allowed to go to the fuel nozzles. This increased flow raises the turbine inlet temperature. The fuel flow will continue to increase until the reference signal is matched by the signal from the remaining thermocouples.

Once this has occurred, the TD system will regard the situation as normal and the flight station TIT indicator will display a normal temperature reading. Actually, the apparent restoration of "normal" operation after the loss of the thermocouple has been accomplished at the cost of increasing the TIT.

Since the engine is now operating at a higher temperature than normal, chances are increased that additional thermocouples may fail, in a sort of domino effect. The engine will then operate at ever-increasing

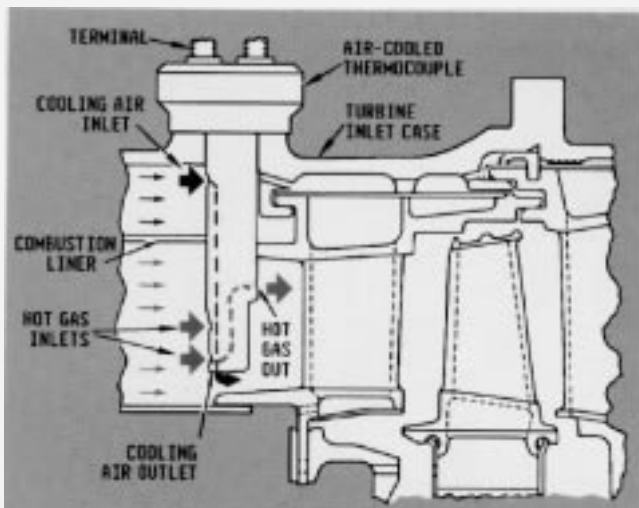

Figure 3. The thermocouple probes sample the gas stream at two levels and measure the composite result.

actual TIT while normal indications continue to be displayed on the TIT indicator. The true TIT can increase up to 3.5°C for each thermocouple that fails because of open junctions. Thus with five open thermocouples, a normal reading of 1077°C might be indicated during takeoff roll, but the true TIT could be in the neighborhood of 1095°C . Such exposure to excessive operating temperatures is very hard on engines.

Probe Tip Aft Wall Erosion

A different thermocouple problem affects mainly air-cooled thermocouples. This is erosion of the probe tip wall, and it has more serious possible consequences than an open-circuit condition. In this case, a hole is eroded in the downstream side of the thermocouple probe tip, but the two sensing elements remain intact.

This kind of damage (see photo 6, page 9) destroys the ability of the thermocouple to measure the temperature of the gas stream accurately. The result is an erroneous signal that will be averaged into the temperature readings being passed along to the TD amplifier and the flight station TIT indicator.

The thermocouples used in 501/T56 engines are temperature sensing, gas sampling devices. Their bimetallic junctions are not exposed directly to the hot gas, but are instead enclosed in a probe. This probe is designed to obtain samples from two different immersion levels in the gas stream, mix the samples, and then direct the composite sample over the sensor junctions within the probe. After the temperature of the composite sample has been measured, the gas is exhausted from the downstream side of the probe (Figure 3).

When the probe tip aft wall is eroded away, the gas-sampling function of the probe is upset. The combustion gases are not properly mixed and are not directed over

the sensor elements before they escape from the downstream side of the thermocouple. This yields a temperature signal that is lower than normal.

Each thermocouple damaged in this way will cause the signal to be approximately 7.5°C too low. Since the TIT signal will now be below the reference signal, the TD amplifier will initiate an increase in the fuel flow to raise the average TIT signal to satisfy the reference signal.

When the system stabilizes, the real TIT will be 7.5°C above the indicated value. Again we have an overtemperature condition, but in this case one of greater magnitude. Multiple failures of this type will compound the problem.

Missing Probe Tips

The last thermocouple problem we will consider in this presentation concerns non-air-cooled thermocouples with missing probe tips. This is potentially the most serious condition of all from the standpoint of the possible effects on the TD control system. In this case, the probe tip is completely missing from the affected thermocouple, but again, the two sensing elements remain intact.

When a thermocouple probe tip is missing (see photo 4, page 8-9), the ability of the probe to perform its vital gas-sampling function is completely lost. The gas sample cannot be obtained from deep within the gas flow where the temperatures are highest. Instead, the sensing elements are exposed to the relatively cool environment at the periphery of the combustion gas path. This means that the affected thermocouple will introduce an excessively low gas temperature signal into the system, with serious consequences for the operation of the engine.

In addition to whatever foreign object damage the separated probe tip may inflict on its way through the turbine, the presence in the system of a thermocouple without a probe tip has a marked effect on the average temperature signal being received by the TD amplifier and TIT indicator. Each missing probe tip will cause the average temperature reading to be about 22°C too low.

Here again, since the TIT signal will then be below the reference signal, the TD amplifier will call for additional fuel to raise the average TIT signal to match the value of the reference signal. The result is a severe overtemperature condition, one much worse than any of those previously described.

To gain an appreciation of just how serious the impact of lost thermocouple probe tips can be, assume that we are operating a T56-A-7 engine that is performing normally except that three of its thermocouples have missing probe tips. Since each (*continued on page 10*)

THERMOCOUPLE INSPECTION Checklist

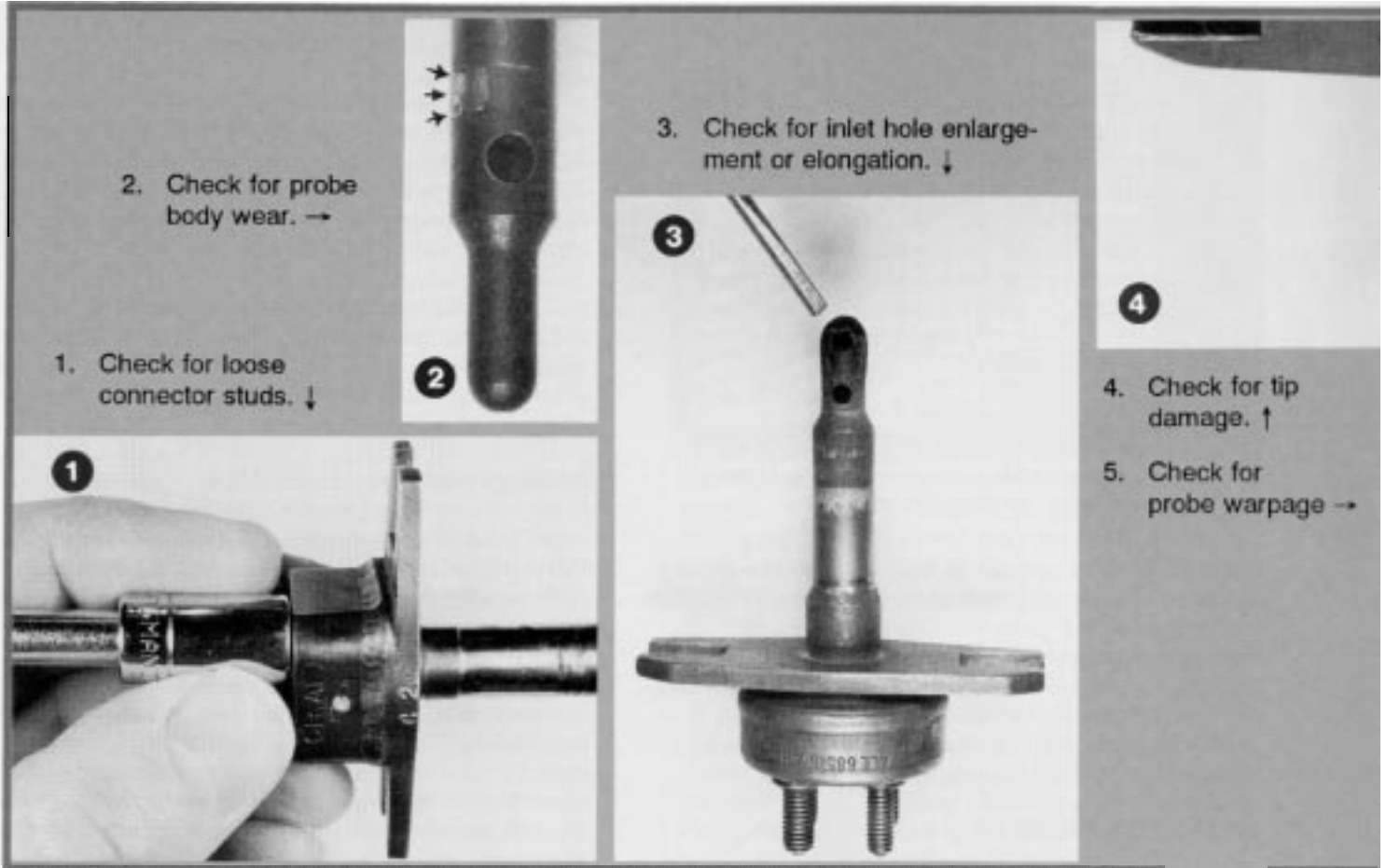

The purpose of thermocouple inspections is to find deteriorating thermocouples before they have failed completely and caused reduced turbine life. Allison recommends that all thermocouples be able to pass each of the following inspection criteria. If a thermocouple fails any of the inspections or test requirements, it must be scrapped.

1. Connector studs. Check the four connector studs for security. Condemn the thermocouple if any stud will turn when you apply a maximum of 25 inch-pounds (2.8 N.m.) of torque to the connector nut when it is bottomed on the stud flange.

2. Probe wear. Check for local probe body wear.

- Reject non-air-cooled thermocouples with local wear exceeding 0.020 inch in diameter on the surface of the main part of the probe body. The probe body in this area is 0.350 to 0.353 inch in diameter.
- Reject air-cooled thermocouples **with** local wear on the main part of the probe that exceeds 0.011 in depth. This section of the probe is 0.409 to 0.415 inch in diameter.

3. Inlet holes. Check the gas inlet holes in the probes of both air-cooled and non-air-cooled thermocouples for enlargement or elongation. A good way to do this is to grind a 0.125-inch drill rod flat on two sides, 1 80° apart. Rotate the drill rod between your fingers while trying to fit

it in the gas inlet holes. Do not use excessive force. Reject any thermocouples which allow the drill rod to enter.

4. Probe tip damage. Reject thermocouples which exhibit burned-off probe tips, or distortion or melting affecting metal strength. The inlet holes must not show a metal buildup. No probe foreign object damage is permitted.

5. Warped probes. Reject any air-cooled thermocouples with a bent or bowed probe. This indicates that an over-temperature condition has existed in this area. Replace the associated fuel nozzle and make a special borescope inspection for damage to the turbine first-stage vanes and blades. Check thermocouples for warpage as follows:

- Insert non-air-cooled thermocouples in the Allison PN 6799628 warpage measuring fixture. Hold the flange tightly against the fixture and rotate one complete turn. Reject the thermocouple if the probe end contacts the fixture.
- For air-cooled thermocouples, or for both thermocouple types if the measuring fixture is not available, reject any thermocouple that shows more than 1 /1 6-inch of bending of the probe tip. Use a straightedge such as a 6-inch steel scale for reference.

6. Probe tip aft wall erosion. Reject any air-cooled thermocouple that has aft wall erosion or gas exit hole enlargement that affects gas flow through the probe.

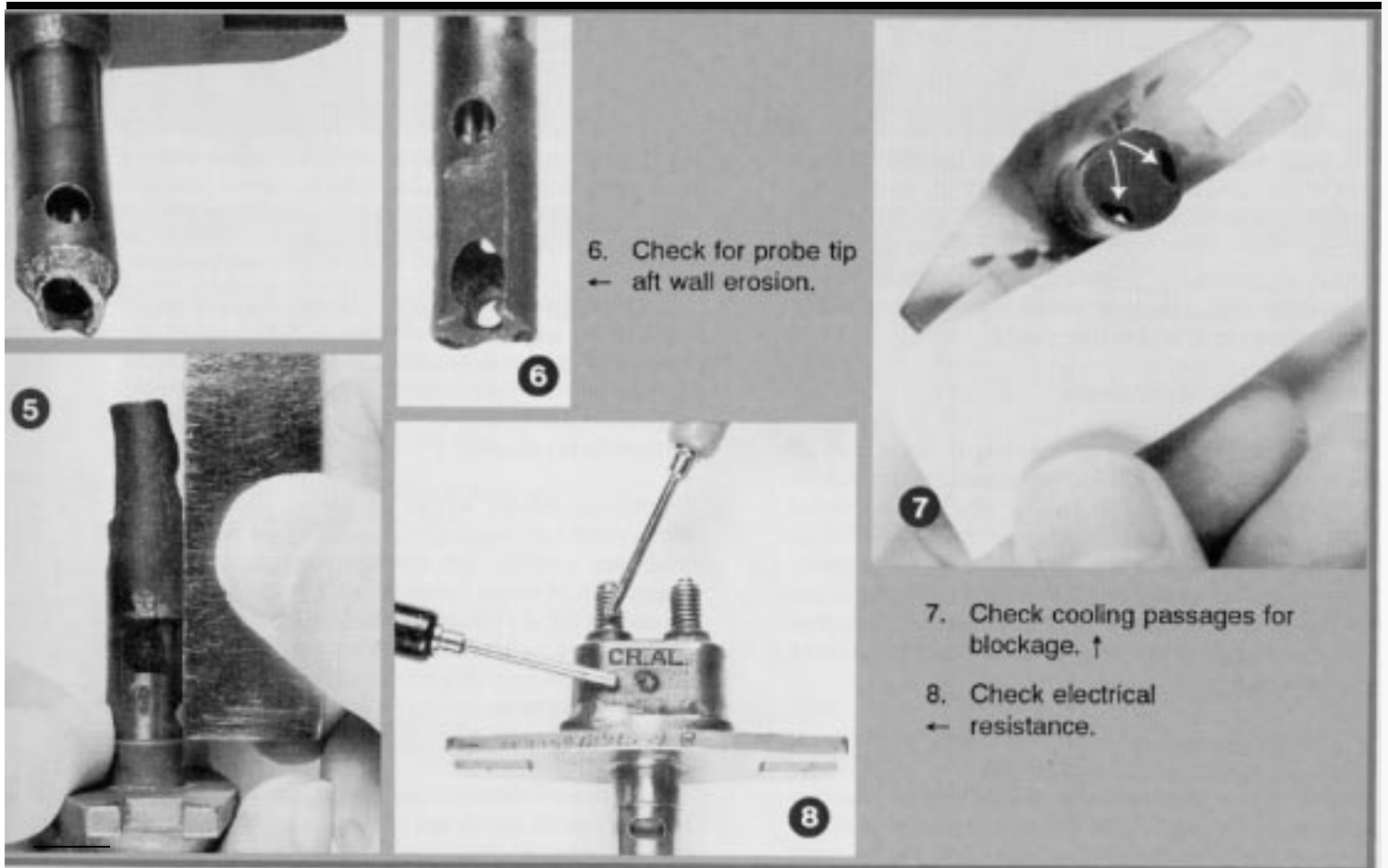

7. Blocked cooling passages. Check air-cooled thermocouples for obstruction of the cooling air inlet and discharge holes, or for any restriction of flow through the cooling air cavity. Inspect the interior area by using a piece of white paper to reflect light into the cooling passage. Use a scribe or similar tool to remove any foreign particles found during inspection. If the blockage cannot be removed, reject the thermocouple.

8. Electrical resistance. Check the resistance between the terminal studs and probe body, and also between the indicator and amplifier studs. If the resistance is less than 20,000 ohms, subject the thermocouple to a temperature of 400°F (204°C) for 30 minutes to drive moisture out of the thermocouple assembly. Allow the thermocouple to cool to room temperature in a dry atmosphere and recheck the resistance. If the resistance reading is still less than 20,000 ohms, reject the thermocouple.

Keep in mind that prolonged engine operation at less than 700°C TIT prior to resistance checking may result in carbon deposits forming within the thermocouple probe. These deposits may cause an indication of low resistance to ground, or low resistance circuit to circuit. Some thermocouples rejected for low resistance may, therefore, be salvageable.

To restore a thermocouple that is fouled by carbon deposits, heat the thermocouple (probe only) in a Jet-Cal tester to 1400°F (760°C). If such a unit is not available,

a carefully employed propane torch may be substituted. Heat the lower 2/3 of the probe to a cherry red glow with the torch and maintain heat for 3 minutes. Be sure to protect the terminal end of the thermocouple from the heat of the torch.

Allow the thermocouple to cool to room temperature and recheck the resistance. Thermocouples that test good after this treatment may be reused if all other test and inspection requirements are met.

Before reinstalling any thermocouples, test each with the Allison PN 6799327 or PN 23003276 Thermocouple Resistance Tester, following the instructions included in the authorized manuals. With 10 amperes of electrical current supplied by the tester, thermocouples that show either of the following symptoms must be rejected:

- The tester meter shows no indication, which strongly suggests an open circuit in the thermocouple.
- The tester meter reads full scale. This indicates a shorted thermocouple.

The bottom line is that a thermocouple should pass each and every one of these requirements to be deemed serviceable. Remember that the point of an inspection is to ensure that the thermocouples that are put back into an engine will be capable of performing properly until the next inspection is due. ■

thermocouple with a missing tip introduces an error that results in the average TIT signal being 22°C below the true temperature, and there are three thermocouples with missing tips, the indicated TIT for this engine is going to be approximately 66°C below the real value.

This means that at an indicated takeoff TIT of 971 °C, the actual TIT would be 1037°C. Even at the maximum continuous Permissible TIT of 932°C indicated, the true TIT would exceed that of takeoff TIT, which is operationally limited to five minutes. Very substantial engine damage could result in short order from operation at such temperatures.

Thermocouple Maintenance

Even under the best of conditions, the effects of heat, erosion, and sulfidation will eventually exact their toll on all thermocouples. This is why thermocouples should be inspected at regular intervals as specified in the authorized maintenance manuals. Since properly functioning thermocouples play such a vital role in the engine control system, a well-designed and conscientiously followed thermocouple maintenance program is crucial to long engine life.

All thermocouples should be regularly removed, inspected, and tested as described in T.O. IC-130B-6 or SMP 515C, and the applicable Allison manual. The text and photos on pages 8 and 9 highlight a number of the steps in the inspection procedures. One of the most important things to remember about thermocouple inspections is to do them often enough. Finding more than three defective thermocouples in one engine at inspection time is a good indication that the period between inspections needs to be shortened.

Defective Fuel Nozzles

When thermocouples are removed for examination, be sure to tag them as they are removed and keep a record of the positions where they were located. The condition of individual thermocouples often provides valuable clues about underlying problems involving other components. Thermocouples with badly burned probe tips or unusual carbon deposits suggest malfunctioning fuel nozzles or defective combustion liners, as does repeated thermocouple failures at the same location.

Inadequate maintenance of fuel nozzles can considerably shorten engine life. Allison recommends that all fuel nozzles be removed regularly, inspected, and functionally tested as part of an ongoing fuel nozzle maintenance program. An inspection interval of 1200 hours is suggested as a starting point for operators initiating such a program.

For operators not equipped to accomplish fuel nozzle inspection at the operating facility, the most practical approach will be to remove the nozzles and replace them every 1200 hours with a set known to be serviceable. Also, don't overlook bad fuel as a possible source of thermocouple problems. Fuel contaminated by dirt or microorganisms can lead to thermocouple trouble by clogging fuel nozzles and altering fuel spray patterns.

Preventing Overtemperature Damage

The proper operation of all 18 dual thermocouples is crucial for long life and efficient performance of any of the power plants in the 501/T56 family. A little extra time and effort spent making sure that these thermocouples are functioning as they were designed to do is a worthwhile investment.

Beyond careful adherence to the thermocouple maintenance and inspection procedures set forth in the authorized manuals, the best insurance against overtemperature damage brought on by malfunctioning thermocouples is vigilance. It is hard to improve upon the protection offered when flight crews and maintenance crews remain on alert for signs and symptoms of something amiss in the TD control system that just might turn out to be thermocouple trouble.

Unusual relationships among torque, TIT, and fuel flow indications are always signs of a problem. This is where the operational hints given at the beginning of this article can be helpful. Adjust engine operation accordingly and then notify maintenance, the sooner the better.

Finally, an important thing to keep in mind is that turbine engines never get better with age. They can only deteriorate as the combined effects of heat, erosion, sulfidation, corrosion, and wear gradually reduce their efficiency. Anytime you see a 501/T56 engine that seems to be getting better as the hours accumulate, don't you believe it! Investigate!

The author and Service News wish to express special thanks to Leon D. Smith, manager of the Allison Gas Turbine Division Southeastern Zone, and his staff for their support and assistance in the preparation of this article.

SERVICE NEWS

1974 INDEX 1991

OF TECHNICAL ARTICLES

Title	Vol.	NO.	Date	Page
AC Bus Power-Off Indicator Relay	13	2	Apr-Jun '86	11
AC Voltage Regulators	4	4	Oct-Dec '77	16
Aerial (Inflight) Refueling Hoses, Repair of Rubber Covering On	4	2	Apr-Jun '77	15
Air Conditioning Screens (The Forgotten Screens)	2	4	Oct-Dec '75	14
Air Conditioning System Temperature Control Sensors, Troubleshooting	12	4	Oct-Dec '85	13
Air Conditioning System, Oil Fumes in	13	2	Apr-Jun '86	10
Air Conditioning Temperature Control System Checkout	5	4	Oct-Dec '78	11
Air Conditioning Units, Hercules New	3	3	Jul-Sep '76	18
Air Conditioning, Hercules	3	2	Apr-Jun '76	2
Air Conditioning, Troubleshooting Hercules	16	2	Apr-Jun '89	3
Aircraft Status Designations, New	5	2	Apr-Jun '78	35
Airframe	6	4	Oct-Dec '79	7
Airframe (update)	16	1	Jan-Mar '89	7
Alloy, New	2	1	Jan-Mar '75	12
Antenna Corrosion, Fighting	14	4	Oct-Dec '87	7
Antenna Wire Breakage, HF	10	3	Jul-Sep '83	14
Antennas, Protecting UHF and VHF	10	2	Apr-Jun '83	15
Anti-Skid, Mark II	8	1	Jan-Mar '81	13
APU and GTC Starters, Identifying	18	2	Apr-Jun '91	17
APU Hoist Assembly Modification	11	1	Jan-Mar '84	14
APU, Herky's New	3	4	Oct-Dec '76	3
ATM (The Air Turbine Motor)	7	4	Oct-Dec '80	11
Atmospheric Dipstick, Using the	13	4	Oct-Dec '86	13
Auto-Tat, Using the Tach Generator Test for an	4	3	Jul-Sep '77	17
Avwash, Lockheed Introduces	12	2	Apr-Jun '85	11
B				
Battery Abuse, SKE and	16	3	Jul-Sep '89	9
Battery Box Noise, Eliminating	16	3	Jul-Sep '89	8
Bleed Air Pressure Regulating Valve Notes	16	3	Jul-Sep '89	10
Boost Pump Electrical Connector	4	4	Oct-Dec '77	18
Borescope, A Flexible Fiber-Optic	8	4	Oct-Dec '81	11
Brake Piston Insulator Inspection Guidelines	13	1	Jan-Mar '86	7
Brakes, Hercules High-Energy	2	1	Jan-Mar '75	10
Brakes, Hot	4	3	Jul-Sep '77	18
C				
C-1 30 Derivatives (1982)	9	3	Jul-Sep '82	
C-1 30, A Promising Future For	6	3	Jul-Sep '79	22
C-1 30Hs for Japan	11	2	Apr-Jun '84	15
Calibration System, Automatic Precision	13	3	Jul-Sep '86	11
Cargo Door, Aft, Actuator Modification	10	2	Apr-Jun '83	9
Cargo Door, Aft, Uplock Binding	8	3	Jul-Sep '81	18
Cargo Door, Quick Fix for a Hanging Door	12	2	Apr-Jun '85	13
Cargo Floor Shoring	6	2	Apr-Jun '79	18
Cargo Ramp Rigging	4	1	Jan-Mar '77	3
Cargo Ramp Rigging Checks	12	1	Jan-Mar '85	3
Circuit Breakers	8	4	Oct-Dec '81	12
Cold Weather Operations	17	4	Oct-Dec '90	3
Connectors, Protecting Multicontact Electrical	16	3	Jul-Sep '89	13
Contactors, Hartman B-123J. Checking and Adjusting	11	1	Jan-Mar '84	3
Corrosion Control, Extending Aircraft Service Life Through	14	2	Apr-Jun '87	3
Corrosion, Preventing Aircraft	17	1	Jan-Mar '90	3
Corrosion, Understanding Aircraft	15	4	Oct-Dec '88	3
Couplings, V-Band, Spare Nuts for	4	4	Oct-Dec '77	18
Cowling Hinge, Upper, Lubrication	4	4	Oct-Dec '77	15

Title	Vol.	NO.	Date	Page
Crew Door Rigging	6	3	Jul-Sep '79	3
Crew Doors, Warped	6	3	Jul-Sep '79	14
Crew Entrance Door Cable	4	3	Jul-Sep '77	17
Crew Entrance Door Open Warning Switch Adjustment, Hercules	2	1	Jan-Mar '75	13
D				
Desert Operations	7	4	Oct-Dec '80	3
Dimensions	6	4	Oct-Dec '79	5
Dimensions (update)	16	1	Jan-Mar '89	5
Door (Crew), Don't Slam the	4	1	Jan-Mar '77	17
Dorsal, Is There Water in-	13	4	Oct-Dec '86	8
E				
Electrical System	6	4	Oct-Dec '79	22
Electrical System (update)	16	1	Jan-Mar '89	22
Emergency Services	6	2	Apr-Jun '79	22
Engine Compressor Washing	13	4	Oct-Dec '86	3
Engine Control Vibration	13	3	Jul-Sep '86	13
Engine Instrument Test Set	13	2	Apr-Jun '86	14
Engine Life, Starting for a Longer	2	2	Apr-Jun '75	3
Engine Oil Loss, Troubleshooting	15	2	Apr-Jun '88	3
Engine Performance Calculator Kit	12	2	Apr-Jun '85	7
Engine Run Safety	18	2	Apr-Jun '91	3
Engine Start Problems, Troubleshooting	4	1	Jan-Mar '77	23
Engine Starter News Notes	17	3	Jul-Sep '90	13
Engine Starting Temperature, Controlling T-56	13	1	Jan-Mar '86	8
Engine Tachometer System, Hercules	1	1	Jan-Mar '74	8
Engine Truss Mount Usage	15	1	Jan-Mar '88	18
Engine, T56 Oil System Maintenance	18	3	Jul-Sep '91	3
Engines, T-56, Preservation of	2	4	Oct-Dec '75	9
F				
Fact Sheet	6	4	Oct-Dec '79	6
Fact Sheet (update)	16	1	Jan-Mar '89	6
Fasteners, Leaky	4	2	Apr-Jun '77	3
Fasteners, Scovill	7	2	Apr-Jun '80	15
FCS-105/C-12 Simulation Test Set, New	11	2	Apr-Jun '84	9
FEDC Valve Installation, Checking	17	3	Jul-Sep '90	7
Filter Elements, New	2	1	Jan-Mar '75	14
Fire Extinguisher Squibs	18	1	Jan-Mar '91	3
Fire on the Flight Deck!	10	1	Jan-Mar '83	3
Flap Jackscrew Interchangeability	18	2	Apr-Jun '81	13
Flap System, Hercules	4	1	Jan-Mar '77	18
Flap System, Hercules (update)	12	3	Jul-Sep '85	18
Flareless Fittings	1	1	Jan-Mar '74	3
Flight Control Cable Tension Regulators	3	3	Jul-Sep '76	14
Flight Data Recorder, A Digital, for the Hercules Aircraft	18	1	Jan-Mar '81	10
Flight Line Obstacle Course	2	1	Jan-Mar '76	3
Flight Simulator, KC-1 30R	4	4	Oct-Dec '77	19
Front Beam, Keeping (It) Clean	10	4	Oct-Dec '83	11
Fuel Compensator Units, Reclaiming	5	3	Jul-Sep '78	14
Fuel Quantity Indicating System, Hercules	1	3	Jul-Sep '74	2
Fuel Quantity Indicating System, New (Digital)	13	3	Jul-Sep '86	3
Fuel Quantity Indication System Connections, Soldering	8	2	Apr-Jun '81	18
Fuel Quantity Indicator Harness Tester	15	4	Oct-Dec '88	14
Fuel Quantity Probes, New	4	1	Jan-Mar '77	22
Fuel Strainer Inlet Assembly Installation	15	3	Jul-Sep '88	14
Fuel System	6	4	Oct-Dec '79	9
Fuel System (update)	16	1	Jan-Mar '89	9
Fuel Tank Infestation, Chemical Control of	10	3	Jul-Sep '83	8
Fuel Tank Maintenance, Materials for	8	2	Apr-Jun '81	11
Fuel Tanks, A Quick Way to Drain Hercules Aux	1	2	Apr-Jun '74	6
Fuel Tanks, Maintenance of Integral	19	4	Oct-Dec '82	3
Fuel Vent System, Hercules	1	1	Jan-Mar '74	14
Fuel Venting, An Update on	15	3	Jul-Sep '88	3
Fuel Venting, Overboard	7	2	Apr-Jun '80	3

Title	Vol.	NO.	Date	Page
G				
GPWS-The Mark II Ground Proximity Warning System	17	3	Jul-Sep '90	3
Grease, Another, a Great Improvement	7	3	Jul-Sep '80	19
Ground Handling, Hercules	3	3	Jul-Sep '76	3
GTF-6 Test Set, Tasting the	8	1	Jan-Mar '81	16
Gyros, The Handling of	6	1	Jan-Mar '79	14
H				
H-Fitting, Meet the	10	1	Jan-Mar '83	13
Heat Exchangers for the Hercules Aircraft, New	10	4	Ott-Dec '83	3
Hercules Flight Training Center	12	2	Apr-Jun '85	3
Hercules, How to Move an Incomplete	2	1	Jan-Mar '75	4
Hercules, Meet the	6	4	Oct-Dec '79	3
Hercules, Meet the (update)	16	1	Jan-Mar '89	3
Hercules, The Amazing	5	2	Apr-Jun '78	23
Hinge Pin, Wing Leading Edge, Installation Tool	4	2	Apr-Jun '77	14
Hoist Safety-Gaging Safetv by the Thread	13	4	Oct-Dec '86	11
Horizontal Stabilizer, Preventing Moisture Entrapment in	14	3	Jul-Sep '87	12
HTTB-The High Technology Test Bed	12	3	Jul-Sep '85	3
Hydraulic Filters, Seals for Hercules Purolator	3	3	Jul-Sep '76	13
Hydraulic Filters, Servicing Hercules	3	1	Jan-Mar '76	15
Hydraulic Fluid Interchange Between Systems	3	3	Jul-Sep '76	16
Hydraulic Fluid Transfer	9	2	Apr-Jun '82	11
Hydraulic Housekeeping	16	4	Oct-Dec '89	14
Hydraulic Pressure Drop	6	3	Jul-Sep '79	15
Hydraulic Pressure-Keeping the Pressure On	10	1	Jan-Mar '83	6
Hydraulic Pump Pressure Lines Check Valve, New	4	2	Apr-Jun '77	15
Hydraulic Pump, How to Bleed a Hercules	1	2	Apr-Jun '74	11
Hydraulic Pump, New	2	3	Jul-Sep '75	12
Hydraulic Pumps, Engine-Driven, A Brief History	10	2	Apr-Jun '83	3
Hydraulic Pumps, Two Different Hercules Engine-Driven	1	3	Jul-Sep '74	15
Hydraulic Systems	6	4	Oct-Dec '79	19
Hydraulic Systems (update)	16	1	Jan-Mar '89	19
Hydraulics, Very High Pressure, It's Here	12	3	Jul-Sep '85	14
I				
Ice Detectors, New	8	1	Jan-Mar '81	17
Index, Cumulative, 1974-I 989	16	4	Oct-Dec '89	9
Index, Cumulative, 1974-1991	18	4	Oct-Dec '91	11
Inflight Vacuum Cleaner System	12	4	Oct-Dec '85	12
Interconnect Valve Positioning Procedure	2	4	Oct-Dec '75	10
J				
JetStar II	2	2	Apr-Jun '75	20
JetStar, Modified, First Flight of	2	2	Apr-Jun '75	23
JetStars, How They Keep Their Cool	1	3	Jul-Sep '74	20
L				
Landing Lights, Adjusting	2	3	Jul-Sep '81	11
Leaks, Locating	2	2	Apr-Jun '75	14
Life Raft Vent Valve Positioning	10	2	Apr-Jun '83	10
Life Rafts	6	1	Jan-Mar '79	3
Lightning and Aircraft	15	2	Apr-Jun '88	13
Liquid Penetrant Evaluation	11	4	Oct-Dec '84	3
Logistics Management System, Standardized	1	2	Apr-Jun '74	7
Lubricants for Hercules Aircraft	9	2	Apr-Jun '82	3
M				
Materials and Processes Technology, A Study in Evolving (Hercules)	8	3	Jul-Sep '81	3
Microbial Growth, Controlling	2	2	Apr-Jun '75	10
MLG Actuators, Steel Cylinders for JetStar	1	2	Apr-Jun '74	12
MLG Ballscrew Lube, Hercules	4	4	Oct-Dec '77	17
MLG Brake Application After Loss of Hydraulic Pressure	11	2	Apr-Jun '84	7
MLG Emergency Extension Update	17	3	Jul-Sep '80	10
MLG Emergency Tiedown Fixture, A New	18	2	Apr-Jun '91	10
MLG Friction Washer Splash Guard	12	3	Jul-Sep '85	22

Title	Vol.	NO.	Date	Page
MLG Inspection, Maintenance, and Emergency Action; Tips for	9	3	Jul-Sep '82	13
MLG Locking Screw, Lost	6	1	Jan-Mar '79	13
MLG Manual Gearbox	7	3	Jul-Sep '80	10
MLG Rub	13	1	Jan-Mar '86	3
MLG Shelf Bracket, New Pin and Bushing for	11	2	Apr-Jun '84	11
MLG Shock Strut Servicing	7	3	Jul-Sep '80	13
MLG Torque Tube Yoke Assembly, Safety Wire for Hercules	3	4	Oct-Dec '76	15
MLG Track Shoe Clearances	6	1	Jan-Mar '79	10
MLG Track Shoe Shop Aid	7	4	Oct-Dec '80	16
MLG Track Wear Gage Blocks	14	2	Apr-Jun '87	12
MLG Upper Shoe Assembly Modifications	6	3	Jul-Sep '79	16

N

Nacelle, Upper, and Wing Dry Bay Plumbing	7	1	Jan-Mar '80	4
NICAD (Nickel-Cadmium) Batteries	1	4	Oct-Dec '74	10
NLG Fulcrum Bearing Noise, Eliminating	18	2	Apr-Jun '91	8
NLG Shimmy	12	4	Oct-Dec '85	3
NLG Switch Adjustments	5	3	Jul-Sep '78	13
NLG, A Handy Rigging Tool	6	1	Jan-Mar '79	9
Nondestructive Evaluation, An Introduction to	11	2	Apr-Jun '84	3
Nose Jack Pad Nut Plates	7	1	Jan-Mar '80	13
Nose Steering System, JetStar	1	1	Jan-Mar '74	8
Nose Wheel Shimmy	3	1	Jan-Mar '76	18
Nuts, Bolts, and Screws	2	3	Jul-Sep '75	3

O

O-Rings	11	3	Jul-Sep '84	3
O-Rings (update)	17	2	Apr-Jun '90	3
Oil Filter, The External Scavenge	2	2	Apr-Jun '75	7
Oil Pressure Transmitter Vent Line on JetStar Engines	4	1	Jan-Mar '77	22
Oil Quantity Transmitters, Solid-State	12	2	Apr-Jun '85	8
Oil Temperature Control Thermostats, Solid State	10	3	Jul-Sep '83	10
Oil, Where Did the (Oil) Go?	2	3	Jul-Sep '75	14
Outflow and Safety Valve Tester, A New	18	1	Jan-Mar '91	8
Oxygen Safety	1	1	Jan-Mar '74	10
Oxygen System, Liquid, Hercules	5	3	Jul-Sep '78	3

P

Packings, Preformed	3	1	Jan-Mar '76	3
Panelocs, Tools For	7	2	Apr-Jun '80	17
Past, A Distinguished	6	3	Jul-Sep '79	19
Pneumatic Systems	6	4	Oct-Dec '79	15
Pneumatic Systems (update)	16	1	Jan-Mar '79	15
Power Fluctuation, Four-Engine	16	4	Oct-Dec '89	3
Power Plant Rigging, Hercules	5	1	Jan-Mar '78	3
Power Plant, Propellers, and the APU	6	4	Oct-Dec '79	12
Power Plant, Propellers, and the APU (update)	16	1	Jan-Mar '89	12
Precipitation Static Dissipation	4	3	Jul-Sep '77	20
Pressure Indicator Leg	2	4	Oct-Dec '75	12
Pressurization Problems, Troubleshooting	8	4	Oct-Dec '81	3
Pressurization Keep a Tight Ship	6	2	Apr-Jun '79	3
Prop Removal and Installation Aid	10	4	Oct-Dec '83	15
Propeller Beta Schedule Checks: The Two-Degree Solution	14	3	Jul-Sep '87	15
Propeller Blade Care, A Guide to	9	1	Jan-Mar '82	3
Propeller Brake, How to Release a Locked	12	4	Oct-Dec '85	8
Propeller Control Oil Level Check, Hercules	1	2	Apr-Jun '74	3
Propeller Dome Shell, Cracked	3	2	Apr-Jun '76	14
Propeller Retaining Nut Torque Values	16	4	Oct-Dec '89	8
Propeller Valve Housing Installation	2	2	Apr-Jun '75	19

R

Radar Indicator, The Bendix PPI-1 P Weathervision	7	1	Jan-Mar '80	6
Radar, APQ- 122	4	4	Oct-Dec '77	3
Radar, Troubleshooting APQ-122	5	2	Apr-Jun '78	3
Radio Compartment Door, The AN/ART-31	8	4	Oct-Dec '81	10
Radome Coatings (Nose), Update on	14	3	Jul-Sep '87	3
Ramp Actuator Damage	8	1	Jan-Mar '81	14

Title	Vol.	NO.	Date	Page
Ramp, Opening the Hercules	1	4	Oct-Dec '74	6
Representatives, Hercules Senior Foreign Field Service	6	1	Jan-Mar '79	15
Rig Pins, More About	5	2	Apr-Jun '78	35
RPM Fluctuation, Troubleshooting	8	2	Apr-Jun '81	3
Rudder System, Preventing Wind-Induced Damage	16	3	Jul-Sep '89	12
Rudder Thrust Bearing Wear, Controlling	10	3	Jul-Sep '83	3

S

Sealing Materials for Hercules Aircraft	14	4	Oct-Dec '87	3
Secondary Fuel Pump Pressure Light Flicker	8	4	Oct-Dec '81	16
Serial Numbers, Lockheed Aircraft	2	2	Apr-Jun '75	19
Serrated Plates, Thinner	4	3	Jul-Sep '77	21
Shutoff Valve Expansion Damage, Preventing	16	2	Apr-Jun '89	13
Sling Assembly, Improving the General Purpose	11	2	Apr-Jun '84	13
SMP-515-E, Illustrated Tool and Equipment Manual	11	4	Oct-Dec '84	14
Solid-State Components	5	3	Jul-Sep '78	12
Starter Control Valve Adjustment	13	1	Jan-Mar '86	9
Starter Oil Leak Detection	9	2	Apr-Jun '82	10
Starter Servicing	3	4	Oct-Dec '76	11
Starter Shaft Seal Repair, Engine	16	3	Jul-Sep '89	15
Starters, Bendix	5	4	Oct-Dec '78	3
Static Discharger Maintenance	15	4	Oct-Dec '88	12
Static Ground Assemblies	4	3	Jul-Sep '77	21
Struts, Understanding	13	2	Apr-Jun '86	3
Synchrophaser Test Sets, Lockheed-Designed	12	3	Jul-Sep '85	15

T

TD Control System, Two New Test Sets for	18	1	Jan-Mar '91	13
Technical Publications, C-I 30	7	3	Jul-Sep '80	3
Teflon Hoses-An Applications Guide	16	3	Jul-Sep '89	3
Teflon, (Polytetrafluoroethylene)	2	1	Jan-Mar '75	9
Temperature Control System, First Aid for the Hercules	3	3	Jul-Sep '76	23
Temperature Control Test Set, New	17	3	Jul-Sep '90	11
Terminal Lugs: Stacking Them Safely	10	4	Oct-Dec '83	6
Thermocouples and TIT	9	3	Jul-Sep '82	3
Thermocouples, Hints for Maintaining	9	3	Jul-Sep '82	6
Thermocouples, Understanding	18	4	Oct-Dec '91	3
Tires	4	3	Jul-Sep '77	3
Tires, Keep Up the Pressure in JetStar	3	2	Apr-Jun '76	15
Torq-Set Screws and Tools	3	4	Oct-Dec '76	11
Torque Strut Bolt	7	2	Apr-Jun '80	19
Towbar Shear Bolts	16	3	Jul-Sep '89	6
Towbar Shear Bolts, Hercules	4	3	Jul-Sep '77	22
Troop Seat Installation Tool	8	1	Jan-Mar '81	13
Truss Mount Clamps, Improved	14	2	Apr-Jun '87	15
Turbine Life, Conserving	14	1	Jan-Mar '87	3
Turbine Problem, How the 1867th FCS Solved a	1	3	Jul-Sep '74	23
Turbine Temperature Troubleshooting	1	4	Oct-Dec '74	3
Turnbuckle Tools	1	4	Oct-Dec '74	5
Turnbuckles, Clip-Locking	12	4	Oct-Dec '85	6

UVW

Upper Bumper Stop Repair Procedure	10	2	Apr-Jun '83	12
Upper Refueling Tube Installation	8	2	Apr-Jun '81	16
Vacuum Cleaner System, Inflight	12	4	Oct-Dec '85	12
Valves, Unauthorized (Accept No Substitutes)	14	3	Jul-Sep '87	10
Washing the Hercules	2	4	Oct-Dec '75	3
Wheel Inspection, Aircraft	5	1	Jan-Mar '78	23
Wheel Well Doors, Delamination of Doors	2	4	Oct-Dec '75	15
Windows, NESA	15	1	Jan-Mar '88	3
Windshield Wiper Alignment Tool	1	4	Oct-Dec '74	9
Wire Identification, Hercules	1	2	Apr-Jun '74	9

 **Lockheed**

Aeronautical Systems Company

Customer Training Systems Department

Lockheed — LASC

Marletta, GA 30063



25 Years With the Hercules . . .

. . . Good Show, RAF!